

(12) **United States Patent**
Conti et al.

(10) **Patent No.:** **US 9,976,731 B2**
(45) **Date of Patent:** **May 22, 2018**

(54) **REMOTELY CONTROLLED AND MONITORED FOLLOWSPOT**

(71) Applicant: **Production Resource Group, LLC**,
New Windsor, NY (US)

(72) Inventors: **Christopher D Conti**, Rutherford, NJ (US); **Ian Clarke**, Grapevine, TX (US); **Dale Polansky**, Duncanville, TX (US); **Diane Miller**, Grapevine, TX (US)

(73) Assignee: **Production Resource Group, LLC**,
New Windsor, NY (US)

(*) Notice: Subject to any disclaimer, the term of this patent is extended or adjusted under 35 U.S.C. 154(b) by 0 days. days.

(21) Appl. No.: **15/583,145**

(22) Filed: **May 1, 2017**

(65) **Prior Publication Data**
US 2017/0237943 A1 Aug. 17, 2017

Related U.S. Application Data

(60) Division of application No. 15/335,206, filed on Oct. 26, 2016, which is a continuation of application No. 15/065,040, filed on Mar. 9, 2016.
(Continued)

(51) **Int. Cl.**
B60Q 1/14 (2006.01)
F21V 21/15 (2006.01)
(Continued)

(52) **U.S. Cl.**
CPC **F21V 21/15** (2013.01); **F21V 9/08** (2013.01); **F21V 9/10** (2013.01); **G06F 3/14** (2013.01);
(Continued)

(58) **Field of Classification Search**

CPC H04N 7/181; H04N 5/247; H04N 5/2351; H04N 5/23296; H04N 5/23203;
(Continued)

(56) **References Cited**

U.S. PATENT DOCUMENTS

4,190,864 A * 2/1980 Dischert H04N 5/2351 348/221.1
4,527,198 A 7/1985 Callahan
(Continued)

FOREIGN PATENT DOCUMENTS

GB 2132329 7/1984
GB 2499123 8/2013
JP 2010078854 4/2010

OTHER PUBLICATIONS

Martin TrackPod 1.8, Mar. 2001.
Martin TrackPod 2.0 Beta, Nov. 2001.
High End DL.2, Oct. 2005.

Primary Examiner — Elmito Brevil

Assistant Examiner — Glenn Zimmerman

(74) *Attorney, Agent, or Firm* — Law Office of Scott C Harris, Inc

(57) **ABSTRACT**

A remote follow spot system includes a remote controller that has separately movable parts that are movable in two orthogonal directions, and a display attached to one of said two separately movable parts. The display receives a video feed from a controlled light, that is controlled to move in the same directions as remote controller. The display hence shows the field of view where the light is pointing. In this way, an operator of the follow spot can control the light without physically being near the light.

16 Claims, 13 Drawing Sheets

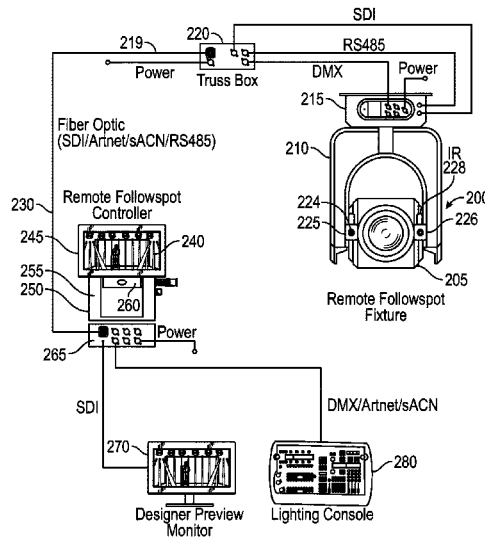

Related U.S. Application Data

(60) Provisional application No. 62/190,063, filed on Jul. 8, 2015.

(51) **Int. Cl.**

H05B 37/02 (2006.01)
F21V 9/10 (2006.01)
H04N 5/225 (2006.01)
H04N 5/232 (2006.01)
H04N 5/77 (2006.01)
H04N 5/235 (2006.01)
F21V 9/08 (2018.01)
G06F 3/14 (2006.01)
H04N 7/18 (2006.01)
H04N 5/247 (2006.01)
F21W 131/406 (2006.01)

(52) **U.S. Cl.**

CPC *H04N 5/2258* (2013.01); *H04N 5/2351* (2013.01); *H04N 5/2353* (2013.01); *H04N 5/23203* (2013.01); *H04N 5/23206* (2013.01); *H04N 5/23293* (2013.01); *H04N 5/23296* (2013.01); *H04N 5/247* (2013.01); *H04N 5/77* (2013.01); *H04N 7/181* (2013.01); *H05B 37/029* (2013.01); *H05B 37/0227* (2013.01); *H05B 37/0245* (2013.01); *H05B 37/0272* (2013.01); *F21W 2131/406* (2013.01)

(58) **Field of Classification Search**

CPC H04N 5/2353; H04N 5/23206; H04N 5/2258; H04N 5/77; H04N 5/23293; F21V 21/15; F21V 9/08; F21V 9/10; H05B 37/0272; H05B 37/0227; H05B 37/029; H05B 37/0245; F21W 2131/406; G06F 3/14

USPC 362/283, 147, 249.03, 249.09, 269, 287
 See application file for complete search history.

(56)

References Cited

U.S. PATENT DOCUMENTS

4,598,345	A	7/1986	Kleeman	
6,079,862	A *	6/2000	Kawashima	G01S 3/7864 348/169
7,071,971	B2 *	7/2006	Elberbaum	H04N 5/2253 348/143
8,201,974	B1	6/2012	Smith et al.	
8,680,972	B2	3/2014	Quadri	
9,014,828	B2	4/2015	Martello et al.	
9,674,458	B2 *	6/2017	Teich	H04N 5/2354
2003/0151909	A1	8/2003	Sid	
2005/0122402	A1 *	6/2005	Kumaki	H04N 5/23212 348/208.1
2005/0259177	A1 *	11/2005	Senoo	H04N 5/2352 348/362
2007/0268680	A1	11/2007	Lee	
2009/0003678	A1 *	1/2009	Cutler	G06K 9/00362 382/132
2009/0144646	A1	6/2009	Reese	
2011/0164422	A1	7/2011	Chan	
2011/0276151	A1 *	11/2011	Feri	H05B 33/0803 700/83
2011/0285854	A1 *	11/2011	LaDuke	G01S 11/00 348/169
2014/0192135	A1 *	7/2014	Babineau	H04N 7/181 348/14.02
2015/0345762	A1	12/2015	Creasman et al.	
2017/0009969	A1 *	1/2017	Conti	H04N 5/23206
2017/0045211	A1 *	2/2017	Conti	H04N 5/23206

* cited by examiner

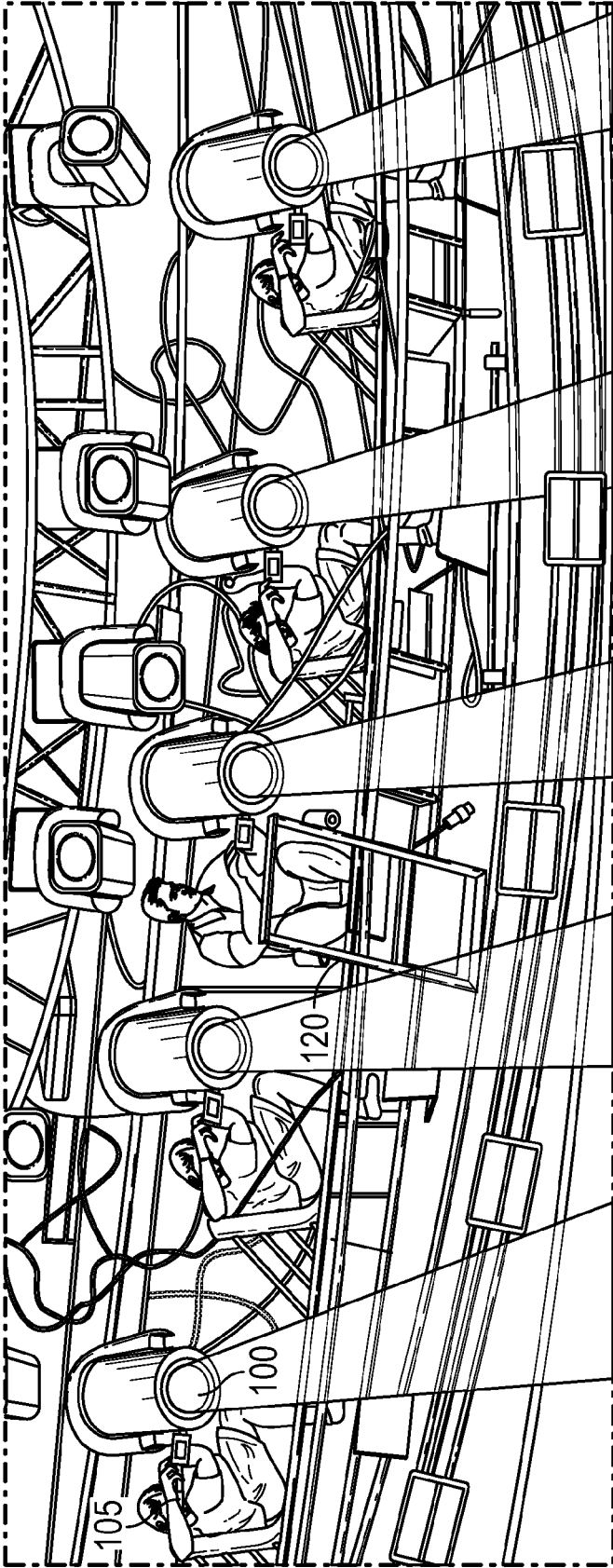

FIG. 1

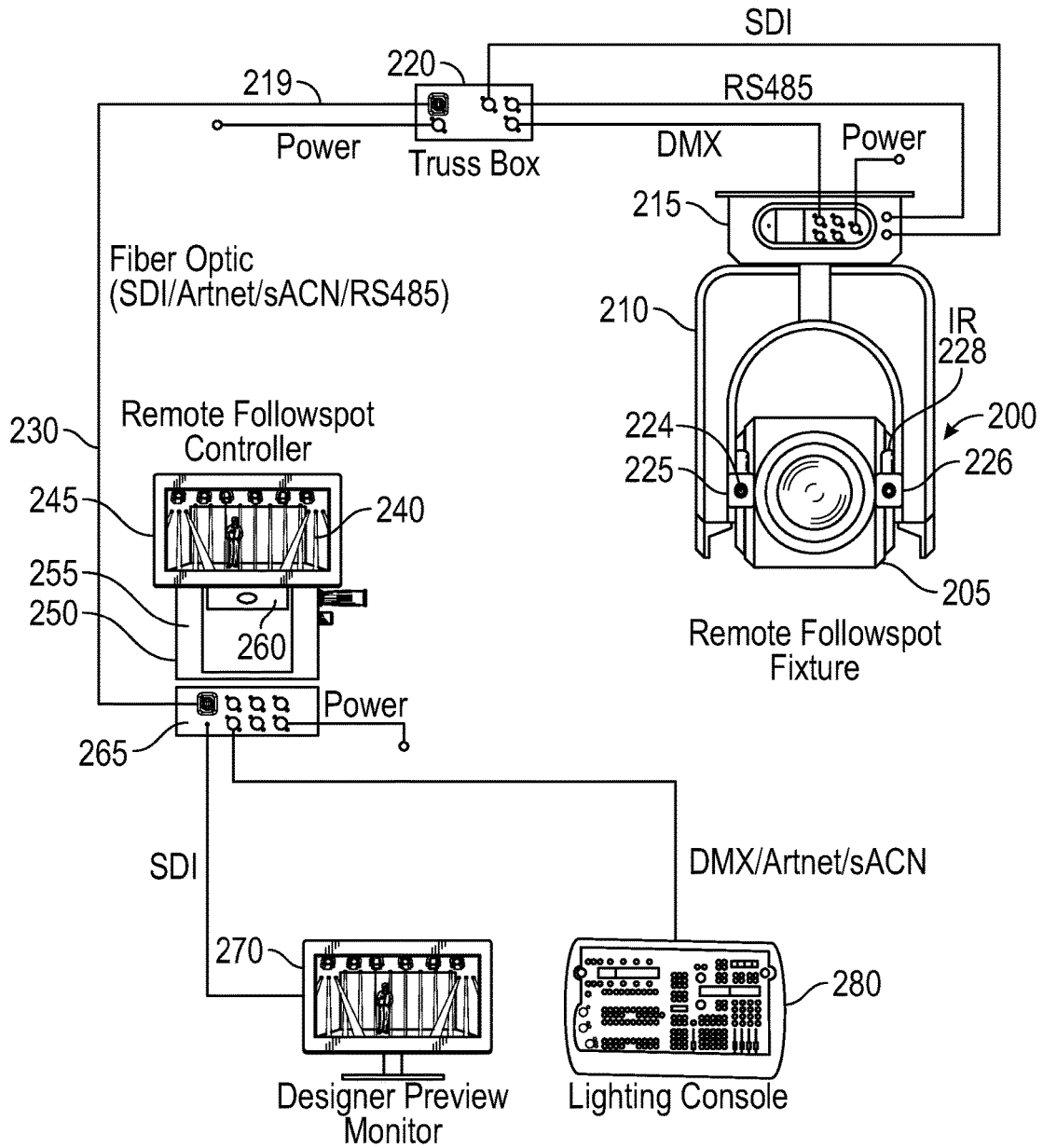

FIG. 2

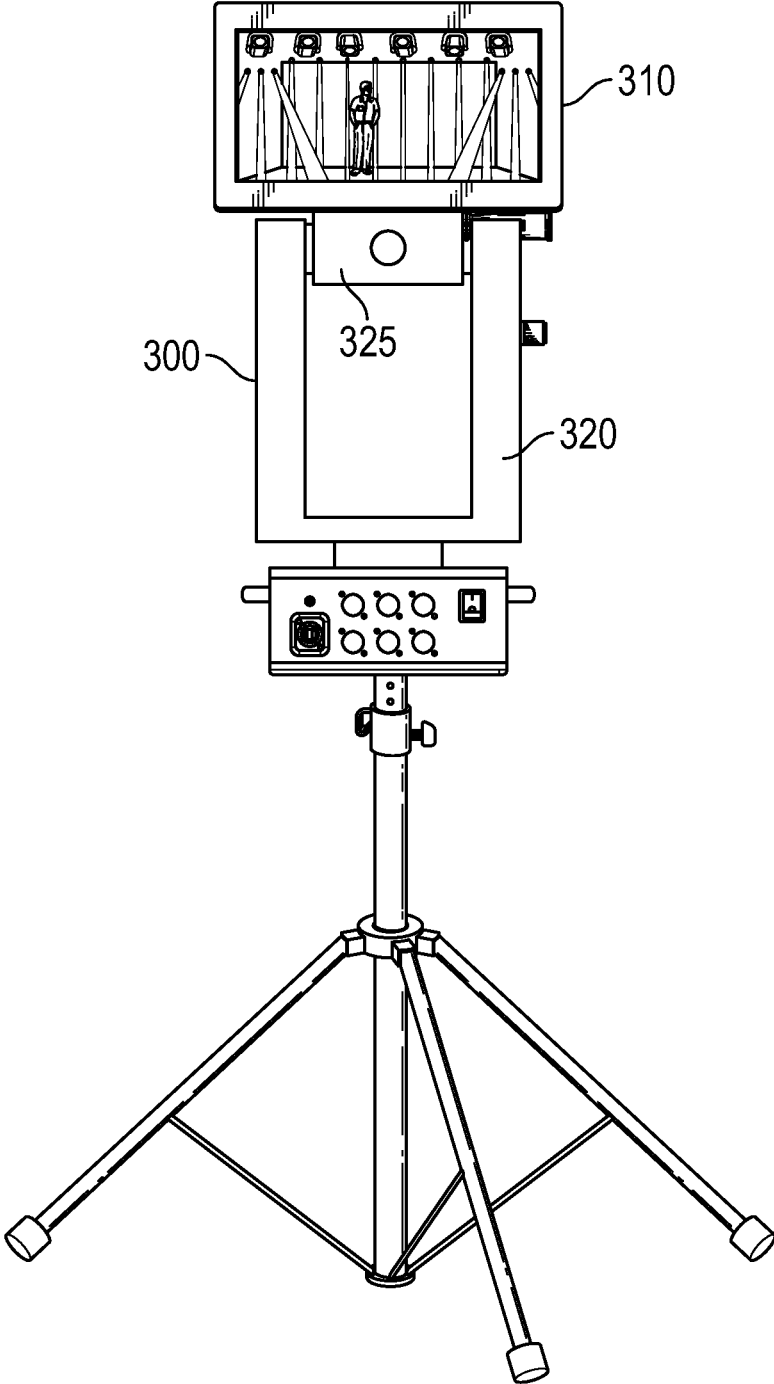

FIG. 3A

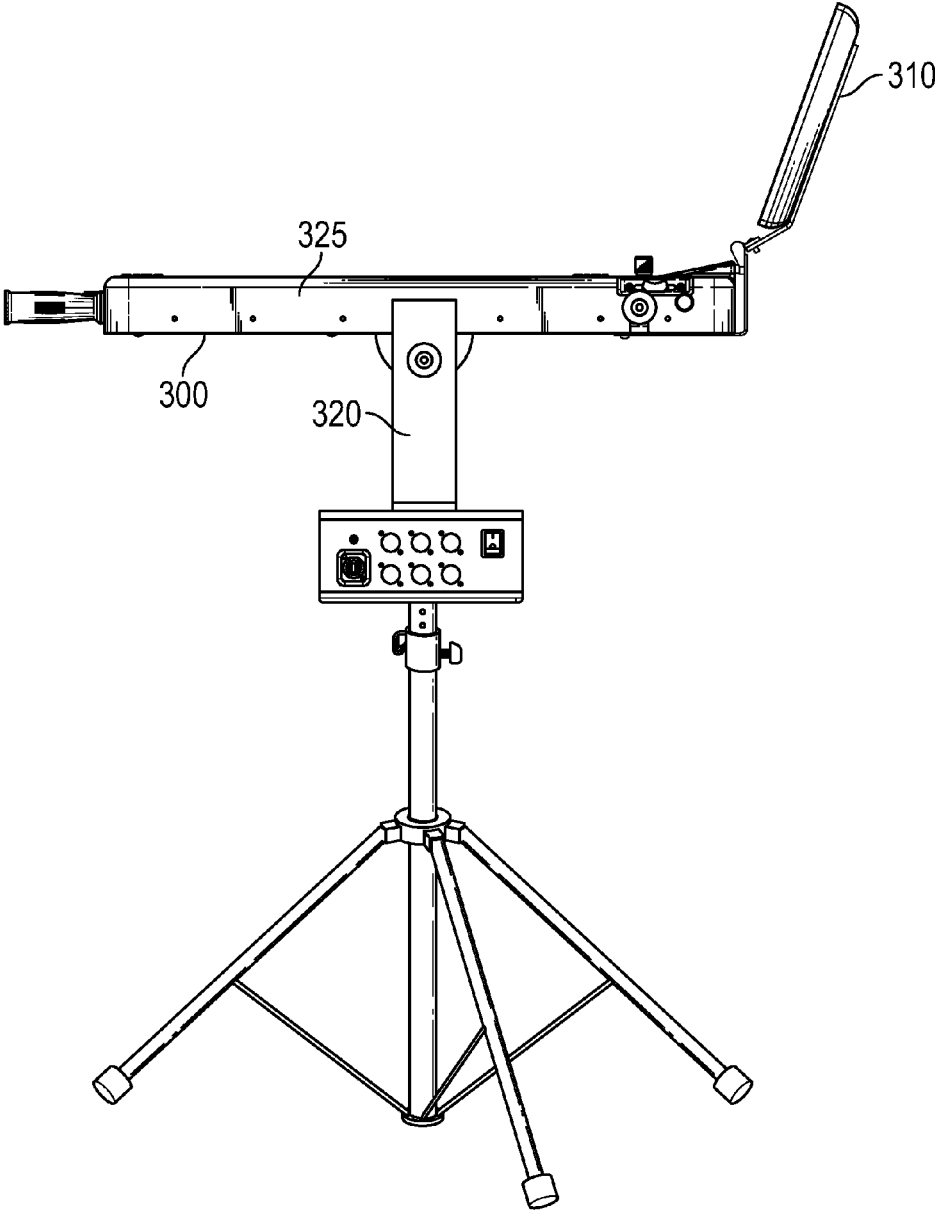

FIG. 3B

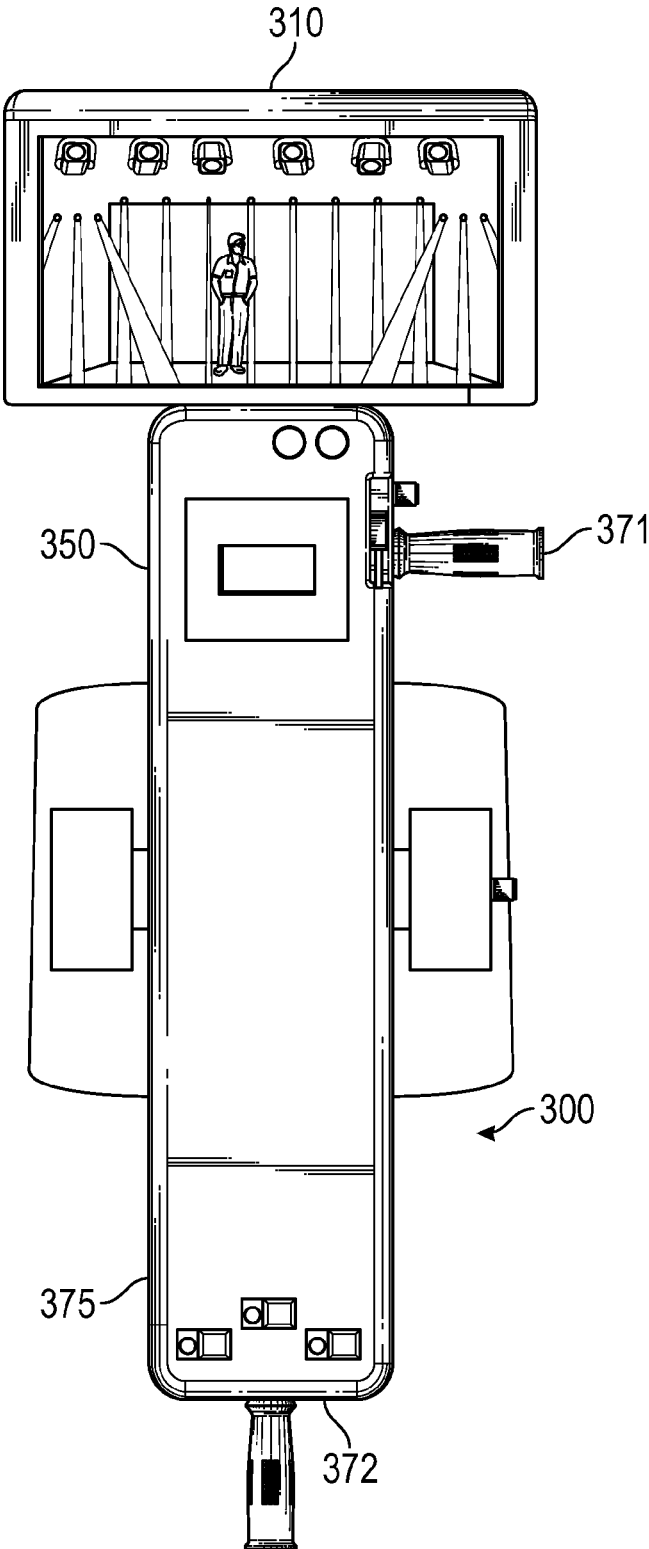

FIG. 3C

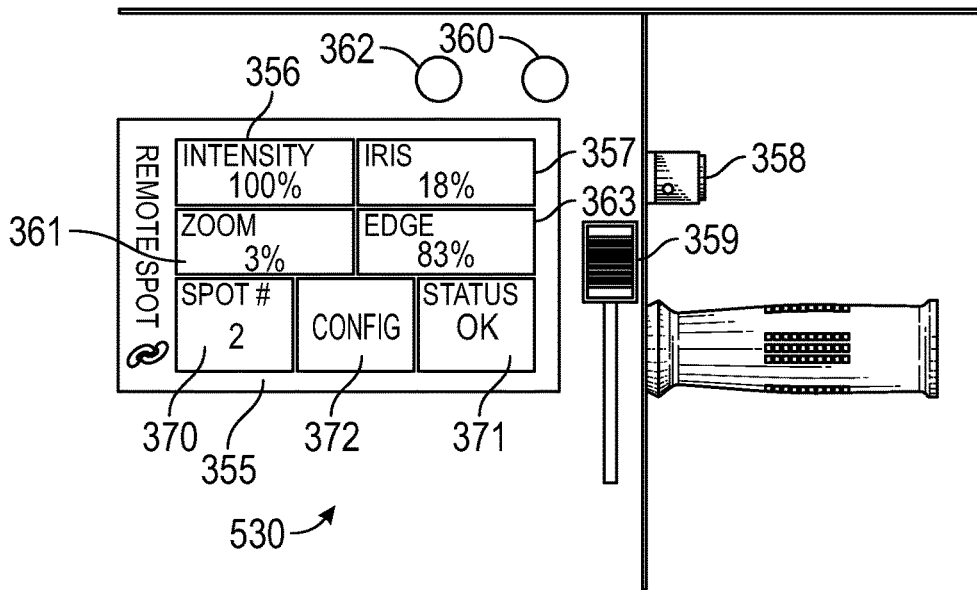

FIG. 3D

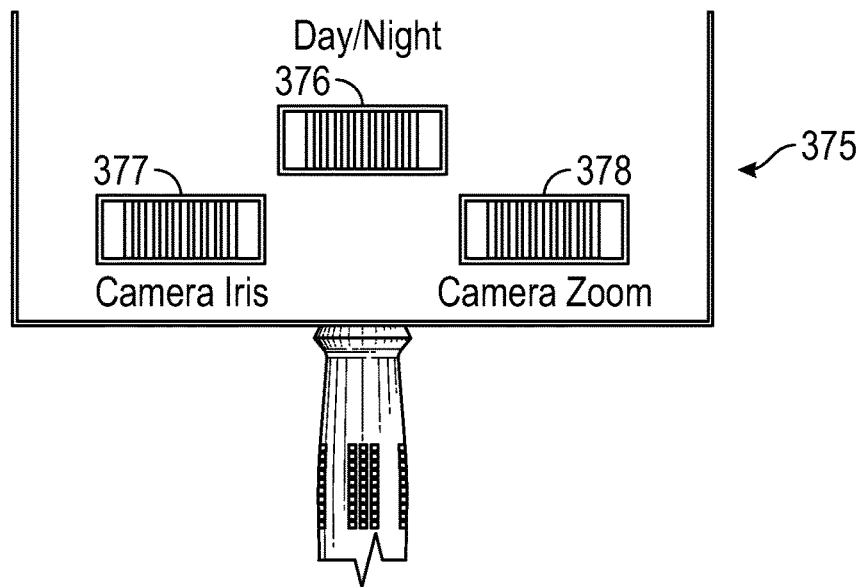

FIG. 3E

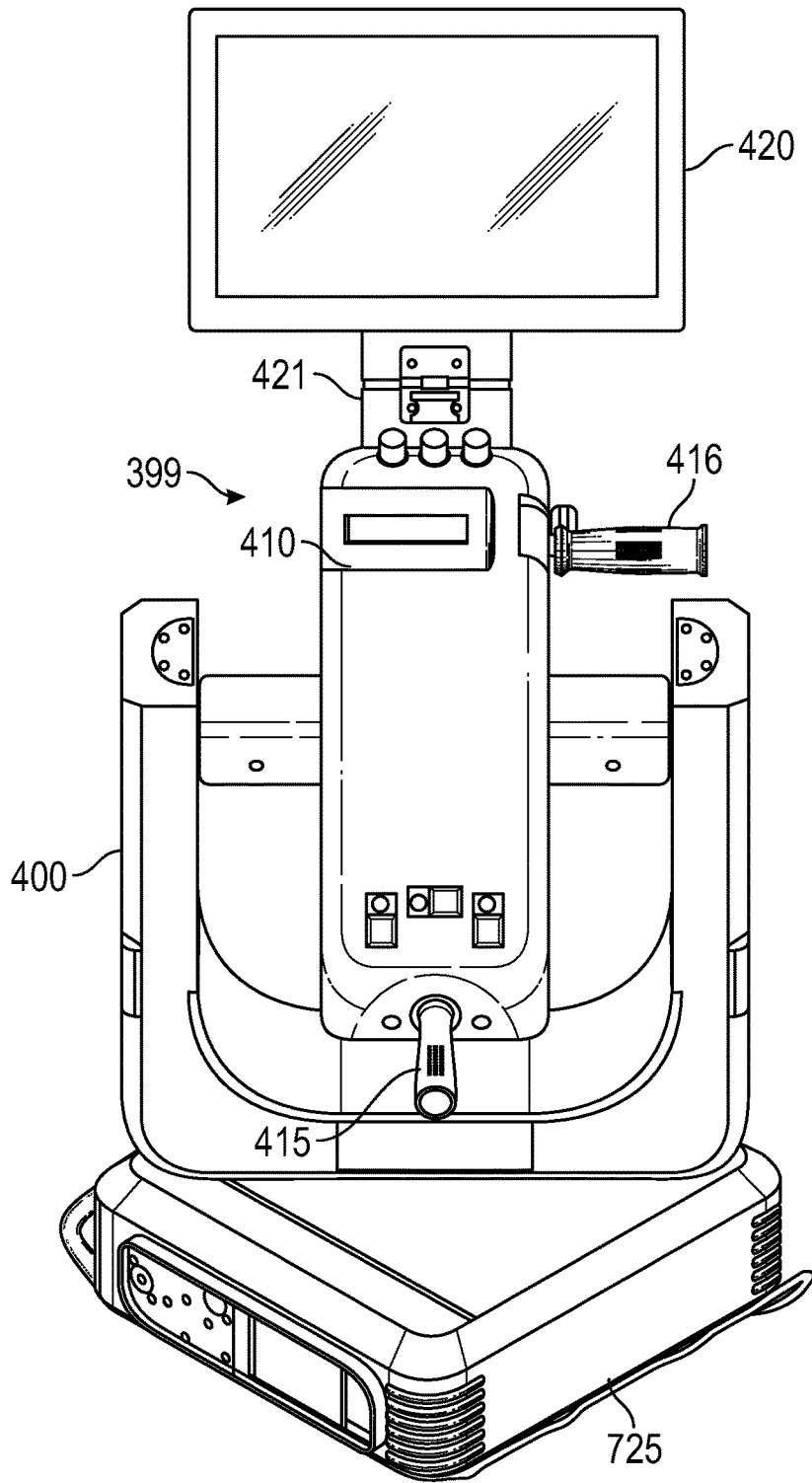

FIG. 4

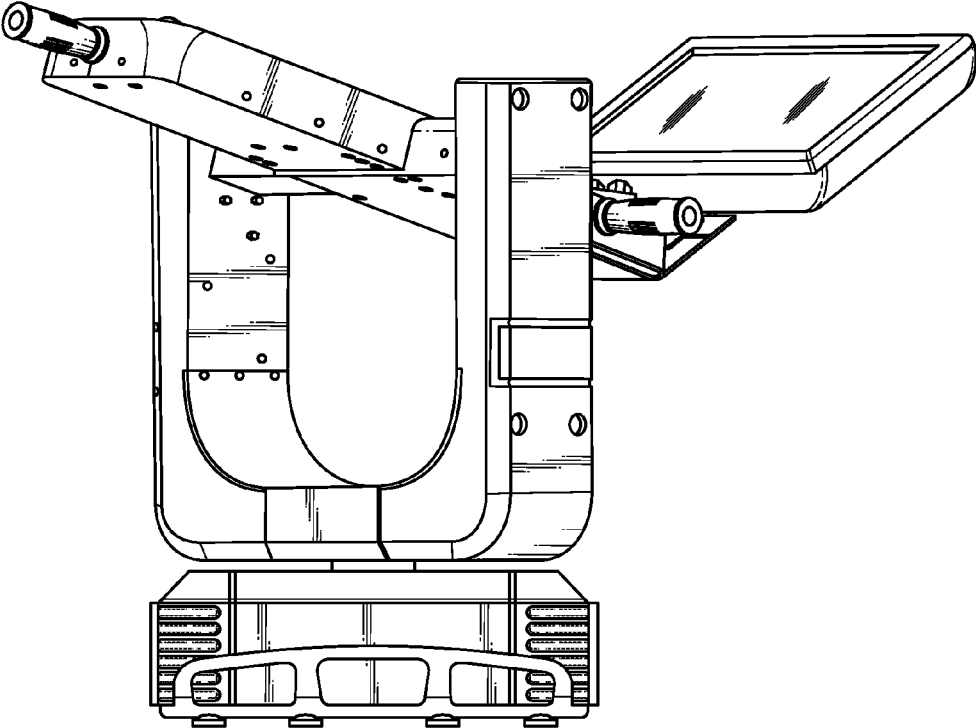

FIG. 5

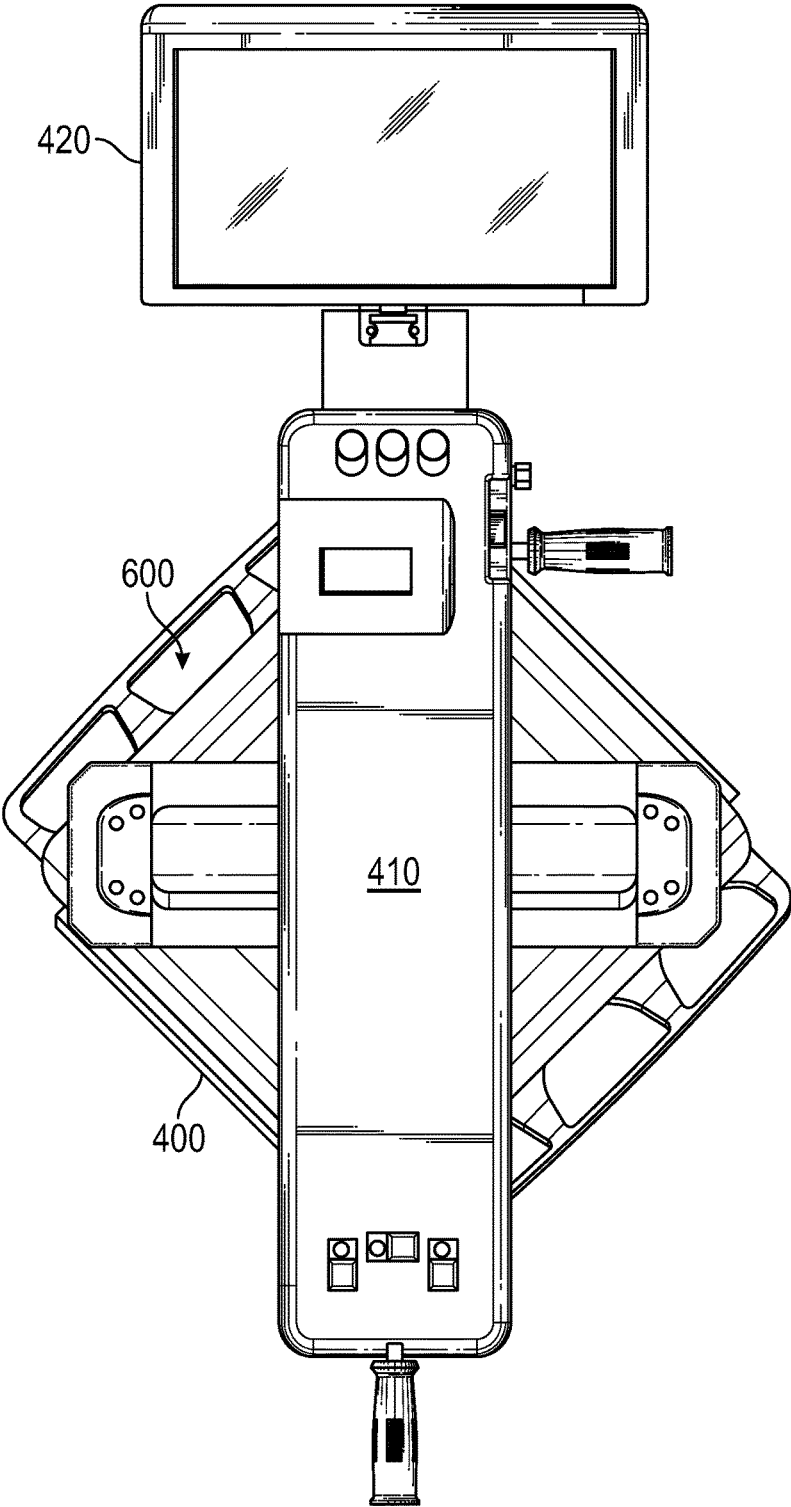

FIG. 6

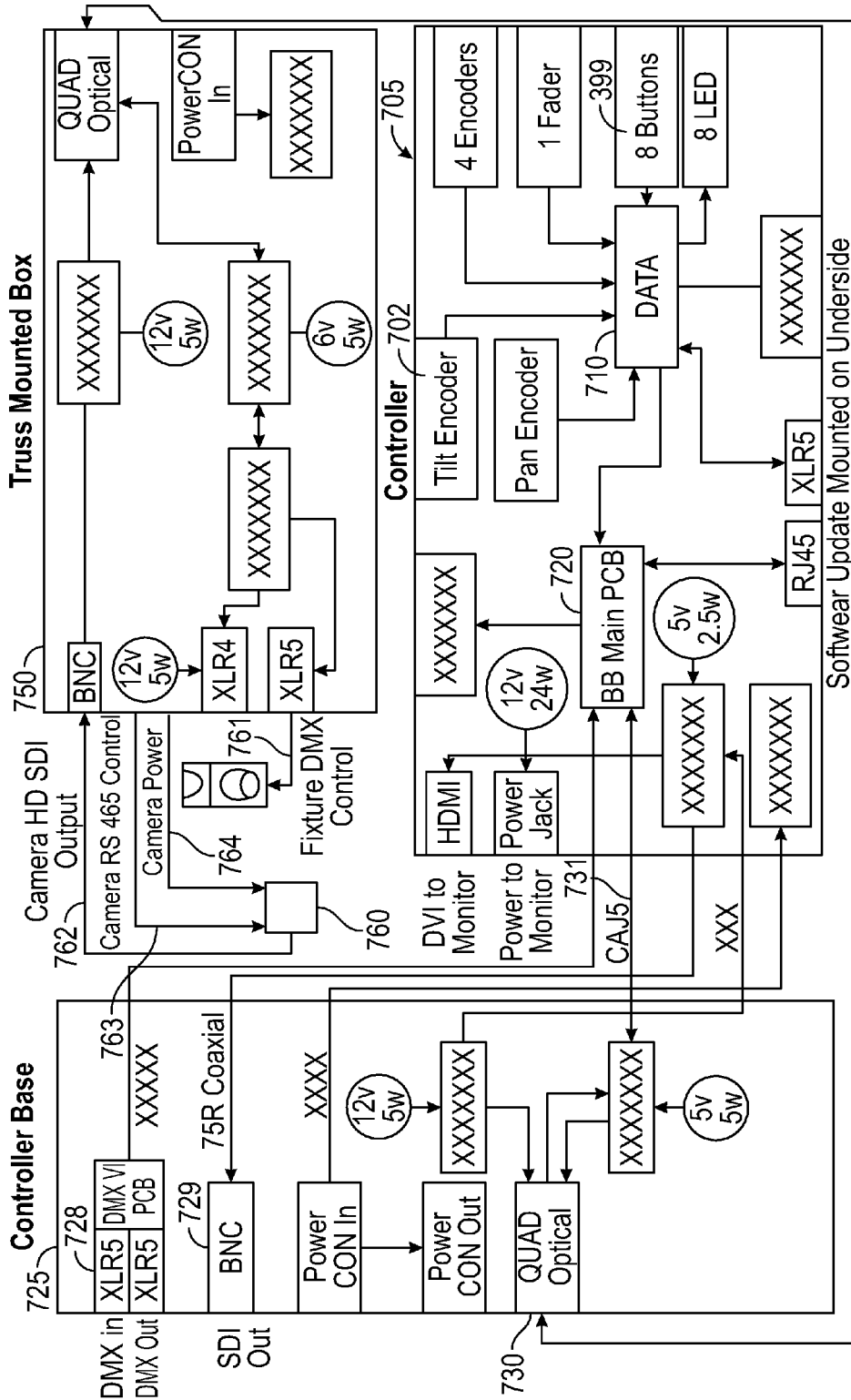

FIG. 7

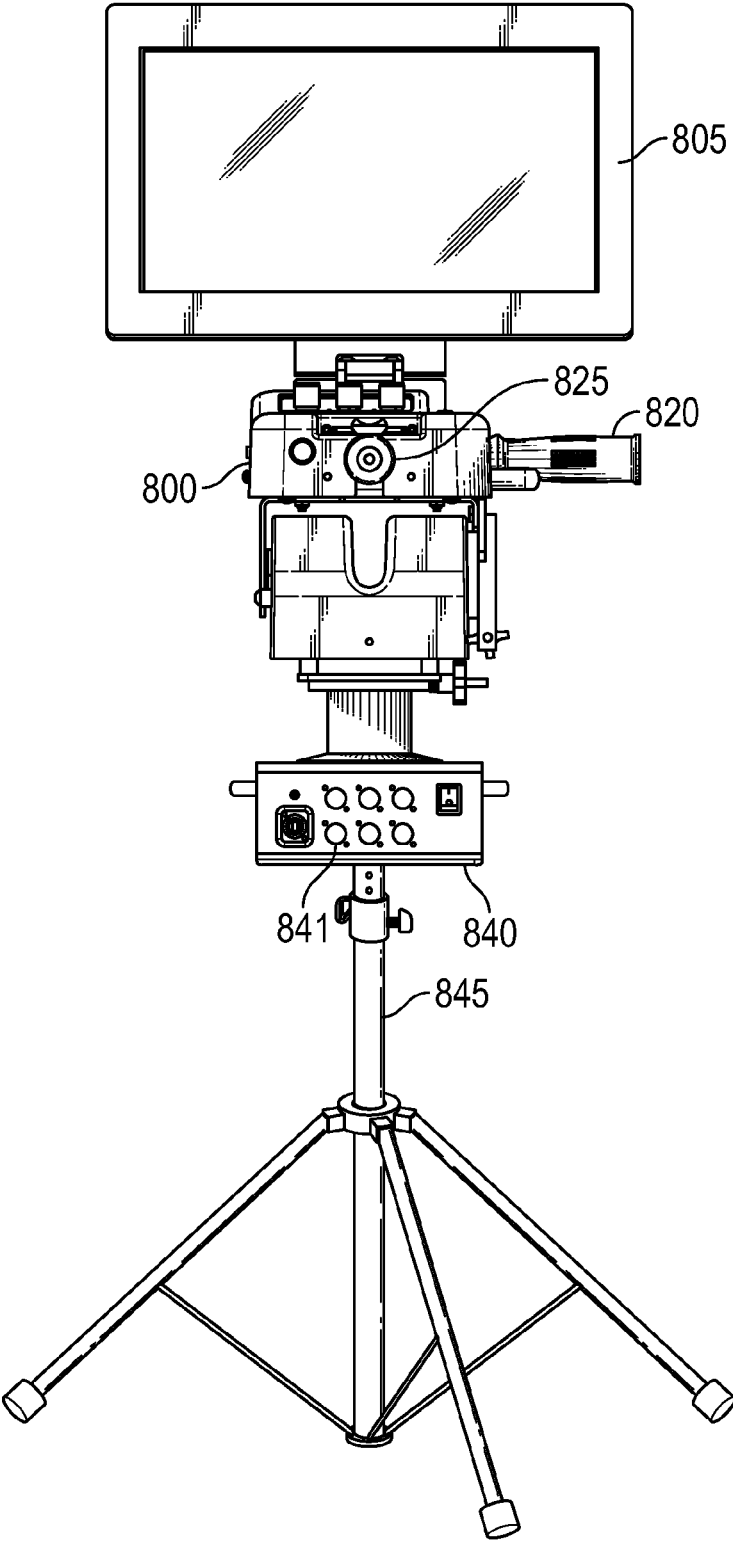

FIG. 8A

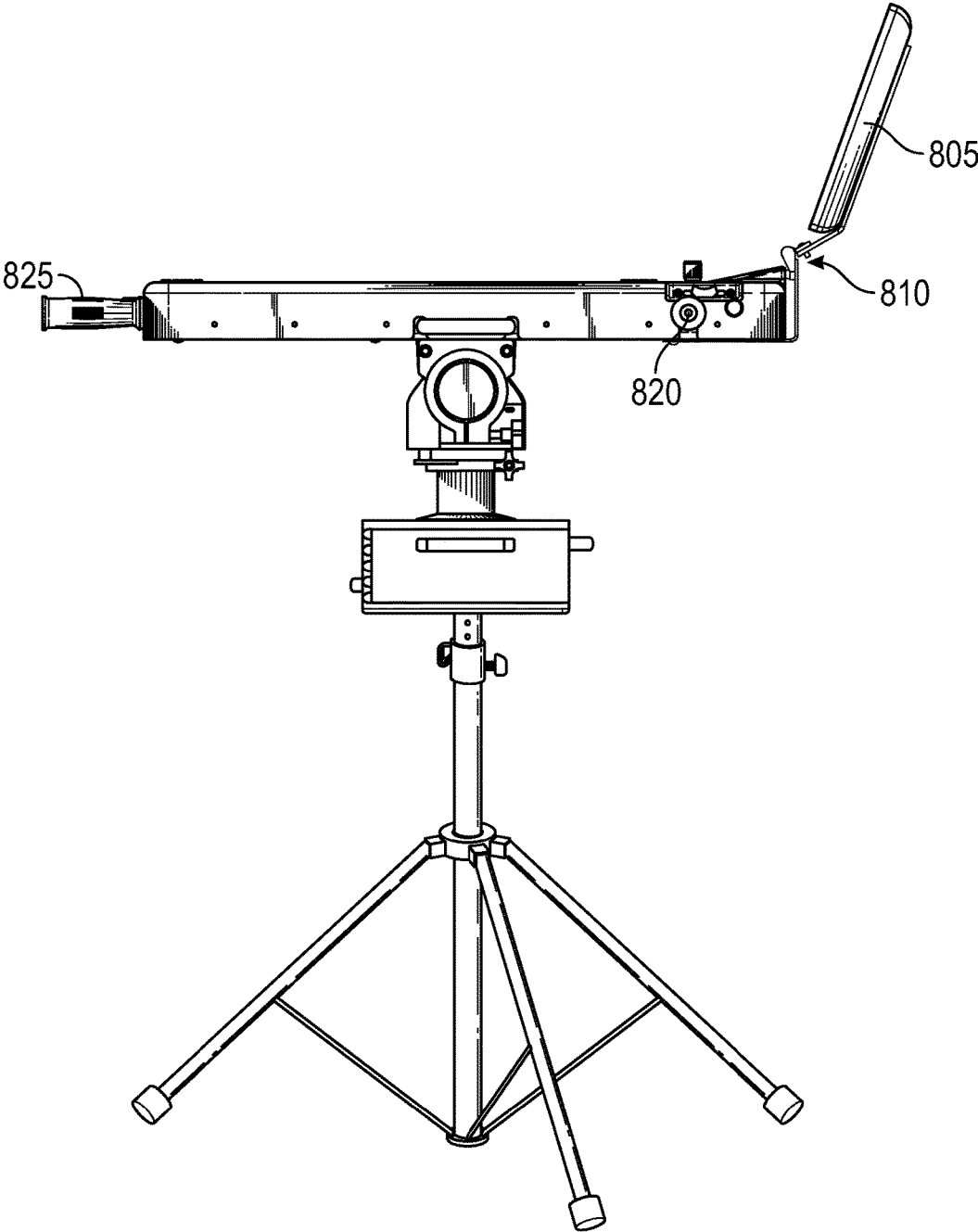

FIG. 8B

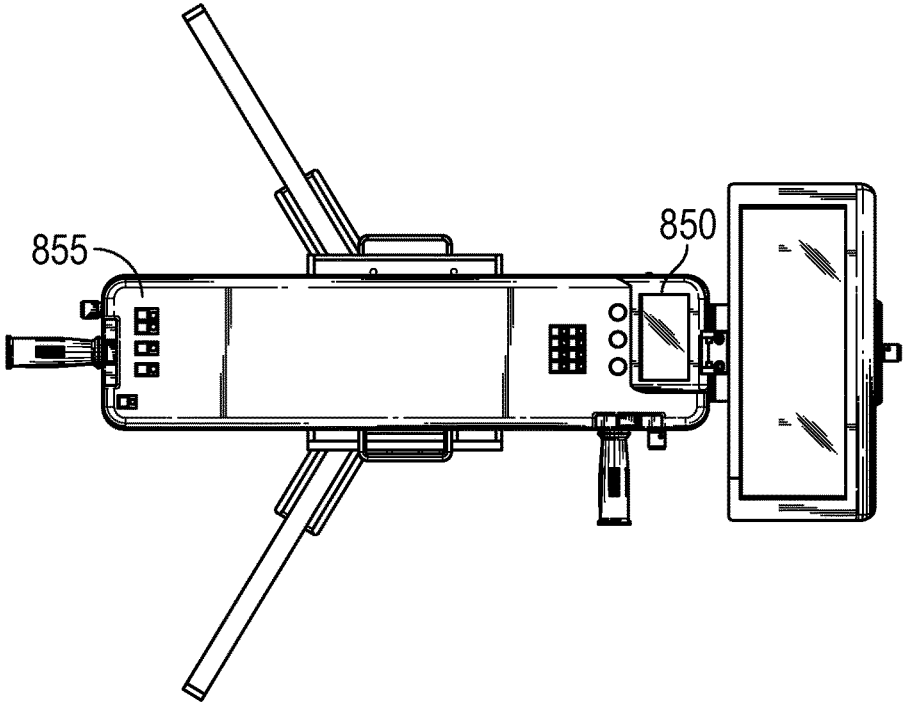

FIG. 8C

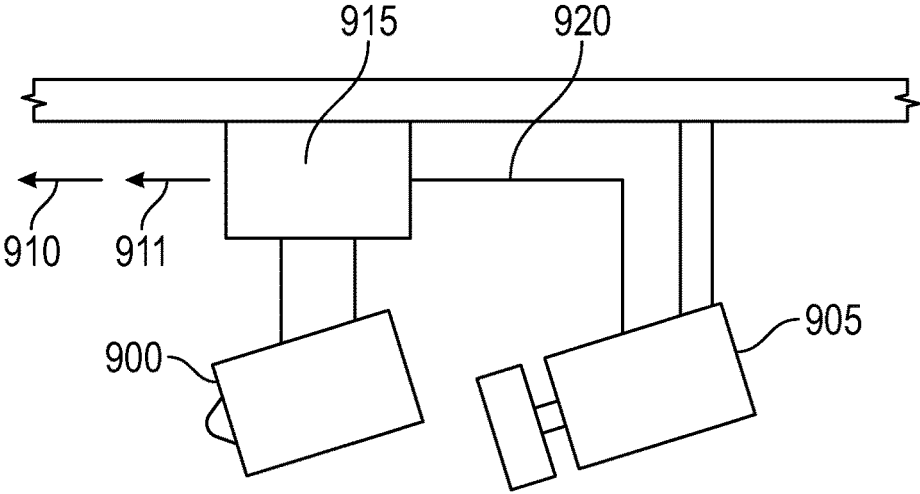

FIG. 9

1

REMOTELY CONTROLLED AND MONITORED FOLLOWSPOT

This application is a divisional of Ser. No. 15/335,206, filed Oct. 26, 2016, which was a continuation of Ser. No. 15/065,040, filed Mar. 9, 2016, which claimed priority from provisional application No. 62/190,063, filed Jul. 8, 2015, the entire contents of each of which are herewith incorporated by reference in their entirety.

BACKGROUND

Manually controlled follow spots have conventionally been controlled by an operator adjacent to the light, manually moving the light using handles on the light. When the light is hung in a truss above the stage, the follow spot operator has also conventionally been seated in the truss. The operator manually moves the light to point the follow spot to follow a performer or item. FIG. 1 illustrates operators also sitting in the truss carrying out the manual control.

The conventional system has a number of drawbacks. It requires one operator per spot. Operators need special training to sit in the truss. It is dangerous for the operator to be high in the truss, and hence special safety precautions are necessary. It is also difficult or impossible for the operators to take breaks during the show. A large amount of space is required for the light and the operators. The truss needs to be designed to handle the weight of the lights and of the operators.

SUMMARY

The present application describes a remotely controlled and monitored follow spot controller, which can be located remote from the follow spot, e.g., on the ground when the follow spot is in the truss and/or at a remote location that is remote from the controller. The controller is moved by the operator. Movements of the controller are monitored by movement encoding devices which translate the movement into electronic signals that are sent to control a pan and tilt controllable light. The movement encoding devices can be devices that produce digital outputs indicative of an amount of angular movement, e.g. a digital encoder, a potentiometer with A/D converter or other. A camera monitors the field of view that is seen by the light. In one embodiment, that camera is attached to the light in order to move with the light. The controller includes a video screen or screens which views the scene that is seen from the light, as the light is moved by movements of the controller. A preferred embodiment of the remote controller operates to control the position of pointing of the light, as well as other parameters of the light, such as the width of its beam or other characteristics of its beam, using an intuitive control which can use the same motions that would be used to move the body of a manually-controlled follow spot. By using this control, any operator who is familiar with controlling using a manual follow spot can control using this electronic remote device.

An aspect receives real-time video into the controller from a camera, e.g., that is mounted on the light, and displays the video on the controller. That same remote controller is also movable to allow moving the light to different positions. The video display screen is attached to the remote controller, and hence movement of the remote controller causes the location on the video-display screen to correspondingly move as the camera attached to the light moves, the field-of-view shown by the camera correspondingly moves.

2

In another embodiment, there can be multiple screens or multiple windows on a single video screen, showing different fields of view, e.g., different resolution or size videos.

The camera can also be mounted separate from the light, in another embodiment.

Another aspect describes an auto exposure system in the camera, that operates to compensate for significantly varying lighting conditions. Another embodiment uses, an infrared or other motion detection system such as RF tracking, to enable tracking and other functions in low lighting conditions.

BRIEF DESCRIPTION OF THE DRAWINGS

In the Drawings:

FIG. 1 shows a conventional Followspot system with operators manually holding handles of followspots while sitting in the truss is adjacent the followspots;

FIG. 2 shows a block diagram of a first embodiment, showing the controller, the controlled light, and the ancillary parts;

FIG. 3A-3E show different views of the controller;

FIG. 4 shows a view of the controller and how it has two parts which pivot in different directions;

FIG. 5 shows the controller pivoted to an additional direction and shows how the display screen can be pivoted to be viewable in this different direction;

FIG. 6 shows a top view of the controller;

FIG. 7 shows a block diagram of the system;

FIG. 8A-8C show an alternate embodiment of the controller; and

FIG. 9 shows an alternate embodiment where the camera is separate from the light.

DETAILED DESCRIPTION

The embodiments describe a remotely controlled and monitored follow spot controller and system. Control of the light is carried out from any location, but most preferably from a location on the ground, remote from the light. A key advantage of this remote follow spot system includes that it allows an operator to control a follow spot without being in a dangerous location such as high above the show venue in a truss. Another advantage is that this can be used in places where traditional or conventional follow spots cannot be used.

FIG. 1 shows how follow spots have historically been operated. The spots are located in a truss, far above the stage. Each of the spots such as 100 has handles 105 that allow manually moving the spot. Each spot also has an operator 120 who holds the spot and moves it manually to follow the desired moving item on the stage. For example, the spots can be used to follow a moving performer, with the operator manually watching the performer, watching the location of the output of their spot and manually moving the spot.

This remotely controlled followspot system allows controlling the position of a remote light, while watching an image of the actual scene illuminated by the light. As the light is moved, the field-of-view that is illuminated by the light also changes. This provides video which can be displayed to an operator as feedback about where the light is pointing.

A camera is used to obtain a real time video image of the scene being illuminated by the light. In order to minimize bandwidth and complexity, alternatives such as stop motion video, or images taken at intervals can be used in place of video.

A first embodiment describes using a touchscreen tablet, such as an iPad, to control the moving position of the light. In this embodiment, the user can view the image seen by the camera on the screen of the iPad. As the light moves, the illuminated image moves, which can be seen on the screen.

The user can move their finger on the touchscreen in order to move the position of pointing of the light. The display screen converts movement of the finger on the display into a light controlling protocol, such as DMX, and sends that command to the remote light. For example, when the operator moves his or her finger up on the screen, this is converted to a signal indicative of move the light up, and sent to the light. The light correspondingly moves up, and the real-time video then shows the light pointing at a different or illuminating a different location. Similarly, the user can move their finger left to right in order to pan the light, or any other combination.

The inventors, however, found that a disadvantage of this system is that it is hard to use. An operator who is accustomed to moving a manually controllable Followspot system needs to learn to move their finger just the right way on the screen. In addition, it was found that holding the user's finger on the screen may cover a portion of the screen that the operator needs to see in order to properly control the light. Removing the finger from the screen, however, causes the light to stop moving.

Another embodiment, described herein, forms the controller from a dual axis movable device. In one embodiment described herein, the controller has the same basic shape as the Followspot itself, with handles in locations which are analogous to those that they would be on a manually controlled Followspot.

A key advantage of this embodiment, using a controller that is shaped to mimic a dual axis movable light, includes that it provides an intuitive ground-based control for a follow spot that allows an operator to operate a follow spot without being in a dangerous location such as high above the show venue in a truss. Another advantage is that this can be used in places where traditional or conventional follow spot cannot be used. Yet another advantage is that since an intuitive control is used, experienced operators can control using the ground-based controller, without significant or any training.

The remote control according to an embodiment can be located anywhere, and is preferably located on the ground, allowing a remote luminaire, e.g., a truss-mounted luminaire, to be controlled via the dedicated controller that is on the ground. The controller is movable. Movement of the controller causes the fixture to move. The fixture as controlled becomes able to be controlled based on a remote control that can be located distant from the light, thus preventing the necessity to put the operator in the truss.

This system provides significant advantages. It provides lighting designers with total creative freedom to put followspots in places that were either previously unusable or involved complex rigging. With the Remote Followspot System, the operator is on the ground so the physical footprint of the fixture can be smaller, and need not have an area or space for the operator. In one embodiment, the fixture is 30 inches round and weighs only 172 lbs. Because of this small footprint and low weight, fixtures can be placed in a wide variety of positions. For example, these remotely controllable followspot lights can be put on balcony rails or on box booms in a theater. The lights can be yoked out over a video wall instead of hanging in front of the wall, which could potentially block viewing access to the video wall. Lights can be hung on box trusses in low trim venues like

convention centers and hotel ballrooms. Lights can be ground supported on a lift or a truss tower. Lights can be hung in a theater on a system pipe in a counter weight fly system. Lights can be placed on the floor of a stage to follow overhead flying.

An embodiment uses a remote controller that is shaped like a miniature light yoke. The controller is moved in the same way that the light yoke would have been moved, and those movements are translated into movements of the light. This control is hence an intuitive control station that mimics the typical form factor and familiarity of a traditional followspot. This enables both experienced and novice users to use the Remote followspot Controller with minimal instruction and total confidence. The Remote followspot Controller has a monitor on the moving yoke whose movements are sent to and mimicked by the Remote Spot in the air. Hence, the view seen through the monitor follows the view that would be seen if the operator were on the truss operating the light.

A first embodiment describes a movable follow spot controller to create outputs to control a standard theatrical automated luminaire, and to receive video signals from a camera mounted on the same light. The controls can be produced in DMX, Artnet, or sACN for example, and real time video is received. Any theatrical automated fixture which can have its pointing direction moved in pan and tilt directions based on remote controls; and can have its lighting characteristics modified based on electronic commands, can be used. A first embodiment modifies an existing fixture for these purposes.

Another embodiment describes a purpose built fixture, which has all of these features built in.

In one embodiment, the fixture uses CMY color mixing, and is further optimized for followspot work by having two dedicated color correction wheels, a CTO, and a CTB wheel. The color correction wheels include filters for controlling a "color" of output light.

FIG. 2 illustrates a block diagram showing an embodiment, where that embodiment covers both the purpose-built fixture and the retrofit fixture. In the purpose built fixture, the electronics to carry out many of these functions are built into the light. In another embodiment, a Truss box is used, which is remote from the light, but communicates with the light, and carries out many of the functions needed for the remote connection. This embodiment uses a controller which is physically separated from the light fixture **200**, which is a remotely controlled pan and tilt controllable lighting fixture, having a lighting head **205** that is movable in pan and tilt direction on a yoke **210**. A truss attachment and electronics module **215** receives both power, and remote control signals including signals in formats of DMX, RS-485, SDI, Artnet, sACN, SAC and and/or RS-485, more generally can be any form of network protocol including ethernet. The controller is mounted on the ground, while the light is mounted on a truss, in one embodiment. The controller controls all light parameters via standard communication protocol, via a control signal sent from the controller to the light. The light, on the other hand, includes a camera mounted on the light which sends back video signals to the operator to view the light aiming or to project the image in real time, or delayed. The movement of the light mimics the movement of the controller as if operating a conventional spotlight. At the same time, the movement of that light is reflected in the video screen which is mounted on the light.

These signals can be routed by wires **219** via truss box **220**, for example when the fixture is mounted on a truss

above a performance. The signals can be routed using ethernet wires, fiberoptic, or Alternatively, the signals can be sent wirelessly, for example.

The fixture **200** also includes cameras **225** and **226** that are attached to the lighting head **205**, to move in conjunction with the moving of the lighting head. The cameras receive the same field of view that would be seen from the fixture. The output of the camera **225** is coupled into the electronics module **215**, and images and/or video received by the camera may be returned over the SDI interface. Alternatively, any other video protocol can be used, including DVI, HDMI, AVI signals, compressed video such as divx, mpeg and matroska, or any other format.

Another embodiment described herein, includes the cameras located adjacent the fixture rather than on the fixture. The cameras can also include pan and tilt capability, and are moved in directions that mimics the movement to the fixture.

Yet another embodiment, uses cameras that are not movable, and which obtain a view of the entire scene being controlled. These cameras, for example, can be used to monitor many different lights, since the operator who views the camera output can see the position of each light on the scene.

In one embodiment, the camera output can be color-coded to indicate which light is which, for example each spot can be color-coded by the computer to indicate its origin.

In one embodiment, more than one camera is used. One of the cameras **225** provides a wide field of view and another of the cameras **226** provides a magnified narrow field of view. The cameras thus provide a real time video feed that is shown on the display screen **245** of the controller. In another embodiment, a single camera is used.

In one embodiment, the cable **219** is a fiber-optic cable between the remote follow spot controller **240** and the fixture **200**. Of course, other network connections can be used.

The feed from the video cameras is displayed on video display **245** which is located adjacent the remote controller **250** and is preferably attached to a moveable part of the controller, so that the video screen moves as the controller is moved.

Manually controlled follow spots often use an externally mounted site/reticle, such as a "Telrad" device. However, this device can use an electronic annotation on the screen in order to carry out the radical function. In this embodiment,

An adjustable targeting reticle can be overlaid on the video image in order to assist with aiming. The targeting reticle can be moved by the operator, to any location on the video screen. For example, the targeting reticle can be maintained on an actors head for example, and the operator tries to move the controller in order to maintain the reticle at the proper location. The operator can also move the location of the reticle on the screen, thereby keeping the target in a desired location relative to the spot. As shown, the remote controller **250** in this embodiment is generally in the shape of a yoke **210** of a moving light. The yoke on the controller has a generally U-shaped yoke part **255** similar in form to the yoke **210** of the follow spot fixture. The yoke **250** is movable in the same way that the yoke **210** on the fixture would be movable should an operator be located in the truss. The controller also has a simulated lighting head **260**, that is also movable and is similar to the lighting head **205** on the fixture. The yoke **255** and head **260** of the remote controller are movable by an operator, in the same way the operator would move the actual head of a follow spot.

Movement of the controller in two dimensions is monitored by pan and tilt movement encoding devices. These

movement encoding devices can be encoders or Any other device that encodes movement into a signal. Exemplary versions of these devices can include a potentiometer whose output is connected to an A/D converter. Another example can be a piezoelectric encoder that encodes the movement into a signal, and that signal again can be A/D converted. Any device which converts movement into an electronic signal can be used as the movement encoding device. The movement is translated by the electronics **265** into a control signal, e.g., in DMX, Artnet, RDM, ACN or sACN or any other lighting control format, either known or custom created, that is sent to the follow spot fixture **200**. Moving the remote **250** thus causes the light **200** to correspondingly move. The movement causes the scene obtained by the camera(s) **225**, **226** to change. The video from these cameras is sent back to the controller **250** and displayed on the screen **245** of the controller **250**. Therefore, as the operator moves the lights, that operator sees in real time, the movement of the scene of the light on the screen **245**.

One problem recognized by the inventors of the present invention is that the conditions of a show of this type can vary quickly between blackout and well lit conditions. The human eye is very good at adjusting quickly, but cameras less so. In one embodiment, at least one of the cameras **225** includes an automatic exposure control **224** that irises up and down quickly in order to quickly adjust for varying lighting conditions. The exposure control can be an iris. In another embodiment the exposure control can be electronically operable, such as an electronic blooming control. The exposure control can be adjusted by a user using the controls described herein, or can be automatically controlled based on a sensor that detects the amount of illumination.

The cameras also are manually and or automatically focused.

Another embodiment provides cameras **225**, **226** that are able to zoom in and out based on a control signal from either the controller **250** and/or a separate lighting console **280** that is connected.

In another embodiment, an infrared illumination source **228** can be used to aid in both targeting and illumination during black out conditions. For example, a thermal imaging camera can be used for targeting during completely black conditions.

All control signals from the controller and video from the fixture travel either on a single and/or multicore fiberoptic cable and or multiple control cables. Multiple controllers and fixtures are thus able to reside on a single network.

A Designer Remote station includes a preview monitor **270** that displays the video feeds from one or more controllers **250**, and a console **280**. The console can be used to control many of these functions, including, for example, exposure control.

The console can carry out many functions, but in one embodiment, the console assigns which lighting parameters are controllable by the remote controller, and which are controlled by the console. The console may be able to take control of any or all lighting parameters. For example, an operator of console **280** may dim some of the lights in the show; for example the console needs to dim **10** of the lights or all of the lights or some other subset. The console takes control of those **10** lights for dimming. During this time, the controllers **250** for the respective ten lights may still be controlling the pan and tilt position of those lights. The console dims those **10** lights. When finished, the console may transfer dimming control back to the respective controllers **250**.

There are also intuitive controls for Intensity, Iris, Zoom, Frost and Edge as well as buttons that can be used for color and beam presets. The Followspot Controller also has an on board touch screen for easy addressing, configuring, and diagnostics. The whole Controller sits on a robust adjustable tripod and has PowerCon in and through, XLR Spin in and through, as well as a BNC that outputs video in any desired format. The Video out is a direct feed from the camera on the Remote Spot and gives designers the added flexibility to use the feed for other functions, such as routing to an LD Followspot Preview Monitor, or others.

The remote movable controller **300**, as shown in more detail in FIGS. 3A, 3B and 3C, is in the shape of an ergonomic yoke that has handles **371** and **372** that allow the remote movable controller to be manually moved by an operator, with the first handle **371** movable to push the pointing position up and down, and the second handle **372** movable from side to side. The user can receive instant feedback on the screen **371**, which shows a video of the pointing position of the light as its movement is controlled. The controller also has controls to control multiple functions including Intensity, Beam, Color and Gobos commonly found in Theatrical Automated Luminaires.

The controller has several control modes. The first mode is fully manual in which all functions are controlled locally by the operator. The second mode is Semi-Manual. In this semi-manual mode, the local operator only has control of limited functions such as pan and tilt. A lighting console **280**, via a DMX512, Artnet, and/or sACN link, controls all other functions. A third Mode is Target mode. In this mode a lighting console pre aims the Pan & Tilt helping a local operator with aiming and picking up an artist or desired object to be illuminated. Once the fixture has been pre aimed, all functions are controlled locally by the operator who is holding the lamp controller **300**.

FIG. 3A shows the yoke controller **300** connected to video screen **310** that shows the real-time video from the pointed-at direction of the fixture. The yoke portion **320** can be pivoted side to side in order to control changing the pan direction of the light. Similarly, the head portion **325** can be moved up and down to control changing tilt direction of the light.

FIG. 3B shows a side view of the controller. The body of the controller **325** is moved side to side and up and down to cause corresponding movement of the light.

FIG. 3C shows a top view. The controller can also include a touchscreen controller/monitor **350** which also indicates the amount of certain parameters. The touchscreen controller **350** is shown in further detail in FIG. 3D. Touchscreen controller **350** in FIG. 3D provides details about the light.

The indicator shows different parameters, described herein. Intensity of the light output **356** is shown as a percentage. Iris amount **357** is also shown as a percentage. A fader **358** on the side of the controller allows the operator to manually control the amount of iris closure. The iris can also be automatic. Alternatively, other exposure control structure can be used in place of the iris.

There is also a dimmer control encoder **359**. As can be seen, the dimmer control encoder **359** is set at its full on position in FIG. 3D, thus causing the intensity to show as full on.

A zoom control **360** can also be used which provides the amount of zoom indicated on the screen as **361**. Similarly, an edge control **362** is indicated on the screen as **363**. The screen **355** also shows information about the light including the number of the light **370** and its status **371**. This can be configured via selecting the configuration screen **372**.

Additional controls **375** are also located at the bottom and of the side of the yoke. A detail of these controls is shown in FIG. 3E. These controls include, for example, camera iris **377**, day/night control **376**, and camera zoom **378** amounts.

In night vision mode, the IR tracker can track the desired spot on the stage e.g. a performer in low light conditions. The camera iris can be used to prevent being "blown out" when the light comes on quickly. The night vision mode enables operators to pick up a performer on a virtually black stage. The controls also include a targeting reticle.

FIGS. 4-6 show an alternative embodiment of the controller. In FIG. 4, the simulated yoke **400** can be twisted, and the simulated head **410** can be moved up and down, thus allowing pan and tilt controls. Both of these controls are controlled by the handles. Handle **415** is pressed up and down to control up and down movement of the simulated light head, the so-called tilt of the light head. The handle **416** is used to control side to side movement of the yoke **400**, so-called pan of the light head. Both the handles are located on the simulated light head, but can be used to control both pan and tilt. That in this embodiment, the tilt moves the simulated light head **410**, but the pan moves the simulated yoke **400**. In this embodiment, both handles are on the simulated light head, but each handle moves a different movable structure.

The operator can move the light head to multiple different positions. The monitor **420** shows the view that is seen by the light via the camera. The monitor **420** is hinged to the simulated head by a hinge **421**. In this way, as the head moves, the monitor **421** can also be moved so that the operator can see the field-of-view of the light.

FIG. 5 shows a different position of the controller, and how when the simulated lighting head is moved, the monitor can be hinged so that the operator can still see the field of view of the light.

FIG. 6 shows the controller from above, showing the simulated head and monitor. The simulated yoke is placed on a support **600** that supports the lighting parts and their movements. That support can be located on a tripod.

FIG. 7 illustrates a detailed block diagram showing the connections between the different parts of the system. The controller **399** corresponds to the parts of the device that are movable. A pan encoder **701** and a tilt encoder **702** encode the pan and tilt movements caused by moving the controller. The controls **705**, including buttons, fader and movement encoders are also acquired by the data acquiring unit **710**. The controls are processed by the main controller board **720** which may be a processor board. All of the controls processed by the processor board **720** are sent to the controller base **725** that encodes the data from the controller into signals in a format to control the movement of the light **760**.

The controller base **725** includes connections for control including a DMX (or other format) connection **728**, an SDI or other format connection **729** as well as an optical connection **730**. The DMX and SDI, for example, can go to an external monitor, while the optical input is connected to the camera in the controller via a connection **731** which can be for example a Cat 5, or Cat 6 connection or a coax connection or a multicore optical connection.

The data to and from the lamp is sent from the optical connection **730** over a fiber, e.g., a quad fiber.

The truss mounted box **750** interfaces to the fiber to exchange information with the controlled lamp **760**. This can include the fixture DMX control **761**, which is sent to the lamp to control the pan and tilt movement of the lamp by the movement of the remote control. The camera output (e.g., video) **762** is also received from the lamp, and passed to the

monitor in the controller. In one embodiment, the truss box can receive controls on the fiber, and output DMX to control the lamp, and RS-485 to control the camera. Video from the High Definition Camera mounted on the fixture outputs HD-SDI in this embodiment at 1080i that enables the operator on the ground to see the stage from the same point of view as if the operator was sitting right next to the fixture. The truss box can also supply power for the camera.

Another embodiment describes the purpose built fixture intended for use entirely with the follow spot controller. In addition to CMY color mixing, this Remote Spot has been further optimized for followspot work by having two dedicated color correction wheels, a CTO, and a CTB Wheel. Both wheels are loaded up with a wide variety of color correction options. The CTO Wheel in one embodiment includes:

Minus Green Filter

1/8 CTO

1/4 CTO

1/2 CTO

3/4 CTO

Full CTO.

The CTB Wheel is loaded with:

Minus Green Filter

1/8 CTB

1/4 CTB

1/2 CTB

3/4 CTB

Full CTB.

Having CMY Color mixing along with the CTO and CTB wheels gives designers the ultimate in flexibility to dial in and tune the Remote Spot to their exact needs.

In another embodiment, the CTO and CTB are variable wheels and not just fixed filters.

FIG. 8 *a*-8C show an alternative embodiment of the controller, from three different angles. The controller body **800** includes a display screen **805** connected thereto by a hinge **810**. The hinge enables the screen **805** to be moved in any desired way depending on the movement of the body. The body can be moved in orthogonal directions, including up and down to tilt and side to side to pan. The body includes handles **820**, **825** which enable holding the body in order to move it. The body is physically mounted on a control box or mounted on the mount that connects to a control box that is mounted on a tripod assembly **845**. The control box **840** may include all the electrical connections such as **841** which enable communication with the remote light. FIG. 8C shows the view from above including the touchscreen controller **850**, as well as other controls **855**.

According to an alternative embodiment, shown in FIG. 9, the camera **900** is physically separate from the light **905**, with the control line **910** interfacing to a truss box **915** that provides pan and tilt control signals for the camera **900**. That truss box also provides the signal including control and power **922** the light itself. In this embodiment, the video signal shown is **911** comes from the truss box received from the light, and need not be received from the light itself. **910** and **911** are shown as two different wires, however this may be on the same physical wire connection.

Other embodiments are intended to be encompassed within the invention. Moreover, the invention is intended to include additional features such as processors, memory, and software. In one embodiment, the software of an existing fixture **205** is modified. In another embodiment, software is used which in essence hacks into the existing fixture in order to cause the fixture to react to the commands from the remote controller.

The controller is shown to have specified shapes and sizes, however other controller shapes can be used. Preferably, the controller is capable of movement in pan and tilt directions, to create the most intuitive control.

An embodiment described herein includes the display screen attached to the controller to move with the controller as the controller is moved to control the light. However in another embodiment, the display screen can be separate from the controller.

As described herein, multiple lights can be controlled with a single controller. A single controller can select which of multiple lights to control in one embodiment. The controller can also control multiple lights at the same time. In one embodiment, this control of the multiple lights may cause all of the multiple controlled lights to point parallel. The operator can select one of the lights, for example the mid-most one for example, and control that one, causing the other lights to point parallel to that one light. In another embodiment, the operator or the console can program information about the locations of the different lights, causing each of those different lights to point at a common location. The operator controls one of the lights, while the others of the lights control are controlled to point at a common pointing location, based on the single control.

In another embodiment, the controller includes software that automatically identifies an image of a target within the video. For example, that target could be a person or some other moving item. The software then attempts to find this target in further video that is received by the controlled luminaire. As the target moves, the software automatically moves the luminaire to keep that target within the center of the video screen. In this way, the target is automatically tracked without the operator's intervention.

Although only a few embodiments have been disclosed in detail above, other embodiments are possible and the inventors intend these to be encompassed within this specification. The specification describes certain technological solutions to solve the technical problems that are described expressly and inherently in this application. This disclosure describes embodiments, and the claims are intended to cover any modification or alternative or generalization of these embodiments which might be predictable to a person having ordinary skill in the art.

Those of skill would further appreciate that the various illustrative logical blocks, modules, circuits, and algorithm steps described in connection with the embodiments disclosed herein may be implemented as electronic hardware, computer software running on a specific purpose machine that is programmed to carry out the operations described in this application, or combinations of both. To clearly illustrate this interchangeability of hardware and software, various illustrative components, blocks, modules, circuits, and steps have been described above generally in terms of their functionality. Whether such functionality is implemented as hardware or software depends upon the particular application and design constraints imposed on the overall system. Skilled artisans may implement the described functionality in varying ways for each particular application, but such implementation decisions should not be interpreted as causing a departure from the scope of the exemplary embodiments.

The various illustrative logical blocks, modules, and circuits described in connection with the embodiments disclosed herein, may be implemented or performed with a general or specific purpose processor, or with hardware that carries out these functions, e.g., a Digital Signal Processor (DSP), an Application Specific Integrated Circuit (ASIC), a

Field Programmable Gate Array (FPGA) or other programmable logic device, discrete gate or transistor logic, discrete hardware components, or any combination thereof designed to perform the functions described herein. A general purpose processor may be a microprocessor, but in the alternative, the processor may be any conventional processor, controller, microcontroller, or state machine. The processor can be part of a computer system that also has an internal bus connecting to cards or other hardware, running based on a system BIOS or equivalent that contains startup and boot software, system memory which provides temporary storage for an operating system, drivers for the hardware and for application programs, disk interface which provides an interface between internal storage device(s) and the other hardware, an external peripheral controller which interfaces to external devices such as a backup storage device, and a network that connects to a hard wired network cable such as Ethernet or may be a wireless connection such as a RF link running under a wireless protocol such as 802.11. Likewise, external bus 18 may be any of but not limited to hard wired external busses such as IEEE-1394 or USB. The computer system can also have a user interface port that communicates with a user interface, and which receives commands entered by a user, and a video output that produces its output via any kind of video output format, e.g., VGA, DVI, HDMI, display port, or any other form. This may include laptop or desktop computers, and may also include portable computers, including cell phones, tablets such as the IPAD™ and Android platform tablet, and all other kinds of computers and computing platforms.

A processor may also be implemented as a combination of computing devices, e.g., a combination of a DSP and a microprocessor, a plurality of microprocessors, one or more microprocessors in conjunction with a DSP core, or any other such configuration. These devices may also be used to select values for devices as described herein.

The steps of a method or algorithm described in connection with the embodiments disclosed herein may be embodied directly in hardware, in a software module executed by a processor, using cloud computing, or in combinations. A software module may reside in Random Access Memory (RAM), flash memory, Read Only Memory (ROM), Electrically Programmable ROM (EPROM), Electrically Erasable Programmable ROM (EEPROM), registers, hard disk, a removable disk, a CD-ROM, or any other form of tangible storage medium that stores tangible, non-transitory computer based instructions. An exemplary storage medium is coupled to the processor such that the processor can read information from, and write information to, the storage medium. In the alternative, the storage medium may be integral to the processor. The processor and the storage medium may reside in reconfigurable logic of any type.

In one or more exemplary embodiments, the functions described may be implemented in hardware, software, firmware, or any combination thereof. If implemented in software, the functions may be stored on or transmitted over as one or more instructions or code on a computer-readable medium. Computer-readable media includes both computer storage media and communication media including any medium that facilitates transfer of a computer program from one place to another. A storage media may be any available media that can be accessed by a computer. By way of example, and not limitation, such computer-readable media can comprise RAM, ROM, EEPROM, CD-ROM or other optical disk storage, magnetic disk storage or other magnetic storage devices, or any other medium that can be used to

carry or store desired program code in the form of instructions or data structures and that can be accessed by a computer.

The memory storage can also be rotating magnetic hard disk drives, optical disk drives, or flash memory based storage drives or other such solid state, magnetic, or optical storage devices. Also, any connection is properly termed a computer-readable medium. For example, if the software is transmitted from a website, server, or other remote source using a coaxial cable, fiber optic cable, twisted pair, digital subscriber line (DSL), or wireless technologies such as infrared, radio, and microwave, then the coaxial cable, fiber optic cable, twisted pair, DSL, or wireless technologies such as infrared, radio, and microwave are included in the definition of medium. Disk and disc, as used herein, includes compact disc (CD), laser disc, optical disc, digital versatile disc (DVD), floppy disk and blu-ray disc where disks usually reproduce data magnetically, while discs reproduce data optically with lasers. Combinations of the above should also be included within the scope of computer-readable media. The computer readable media can be an article comprising a machine-readable non-transitory tangible medium embodying information indicative of instructions that when performed by one or more machines result in computer implemented operations comprising the actions described throughout this specification.

Operations as described herein can be carried out on or over a web site. The website can be operated on a server computer, or operated locally, e.g., by being downloaded to the client computer, or operated via a server farm. The website can be accessed over a mobile phone or a PDA, or on any other client. The website can use HTML code in any form, e.g., MHTML, or XML, and via any form such as cascading style sheets (“CSS”) or other.

The computers described herein may be any kind of computer, either general purpose, or some specific purpose computer such as a workstation. The programs may be written in C, or Java, Brew or any other programming language. The programs may be resident on a storage medium, e.g., magnetic or optical, e.g. the computer hard drive, a removable disk or media such as a memory stick or SD media, or other removable medium. The programs may also be run over a network, for example, with a server or other machine sending signals to the local machine, which allows the local machine to carry out the operations described herein.

Also, the inventors intend that only those claims which use the words “means for” are intended to be interpreted under 35 USC 112, sixth paragraph. Moreover, no limitations from the specification are intended to be read into any claims, unless those limitations are expressly included in the claims.

Where a specific numerical value is mentioned herein, it should be considered that the value may be increased or decreased by 20%, while still staying within the teachings of the present application, unless some different range is specifically mentioned. Where a specified logical sense is used, the opposite logical sense is also intended to be encompassed.

The previous description of the disclosed exemplary embodiments is provided to enable any person skilled in the art to make or use the present invention. Various modifications to these exemplary embodiments will be readily apparent to those skilled in the art, and the generic principles defined herein may be applied to other embodiments without departing from the spirit or scope of the invention. Thus, the present invention is not intended to be limited to the embodi-

13

ments shown herein but is to be accorded the widest scope consistent with the principles and novel features disclosed herein.

What is claimed is:

1. A luminaire comprising:
 - a electronics module, receiving a first control signal to control a pointing direction of a light output of the luminaire, and receiving power,
 - said first control signal received from a remote controller;
 - a head of the luminaire, having a controllable light source therein, said head being movable in both pan and tilt directions in response to said first control signal, and where moving in the pan and tilt directions is carried out responsive to the first control signal, and changes said pointing direction of the light output of the luminaire;
 - a first camera attached to said head, and pointing in said pointing direction to receive the same field of view as the light output of the luminaire, said first camera providing a first camera output that points in a same direction as said head, when said head is moved, said first camera providing output indicative of a wide field of view;
 - a second camera attached to said head, also pointing in said pointing direction to receive the same field of view as the light output of the luminaire, and providing a second camera output that points in a same direction as said head, in all positions of said head as said head is moved, so that both the first and second cameras always point in the pointing direction to receive the same field of view as the light output of the luminaire, said second camera providing output indicative of a magnified narrow field of view,
 - said first camera and said second camera receiving power from said electronics module, and said first camera and said second camera providing both said first camera output and said second camera output respectively to said electronics module, and where said electronics module couples said first camera output and said second camera output to said remote controller.
2. The luminaire as in claim 1, wherein one of said cameras includes an exposure control that irises up and down quickly in order to quickly adjust for varying lighting conditions.
3. The luminaire as in claim 1, wherein said first control signal is in DMX format.
4. The luminaire as in claim 1, wherein said first camera output and said second camera output are video outputs, which are sent in a video format to said remote controller.
5. The luminaire as in claim 1, wherein said first control signal includes at least one camera control signal, which adjust parameters of the camera based on the camera control signals in the electronic control signals.
6. The luminaire as in claim 2, wherein said exposure control is adjusted by a user control, in response to said first control signal.
7. The luminaire as in claim 6, further comprising a sensor that detects an amount of illumination, wherein said exposure control is automatically controlled based on the amount of illumination detected by the sensor.
8. A method of operating a lighting head system, comprising:
 - receiving electronic control signals from a remote controller, and moving a lighting head in both pan and tilt directions in response to the received electronic control signals;

14

- said electronic control signals including parameter control signals, and adjusting parameters of said lighting head in response to the electronic control signals;
 - said electronic control signals including camera control signals,
- further comprising:
 - adjusting parameters of a camera based on the camera control signals in the electronic control signals;
 - monitoring a light output of said lighting head using a first camera imaging an area of illumination by said lighting head, said first camera providing output indicative of a wide field of view;
 - monitoring the light output of said lighting head using a second camera imaging said area of illumination by said lighting head, said second camera providing output indicative of a magnified narrow field of view; and
 - moving the first and second cameras in pan and tilt directions based on said electronic control signals to face the first and second cameras in the same direction as the lighting head, at all positions of the lighting head.
9. The method as in claim 8, wherein at least one of the cameras includes an automatic exposure system, that compensates for varying lighting conditions.
10. The method as in claim 8, wherein said parameter control signals control a zooming of the cameras.
11. A luminaire system comprising:
 - a lighting head having a controllable light source therein, said head being movable in both pan and tilt directions in response to electronic control signals that are received from a remote controller;
 - a first camera imaging an area of illumination by said lighting head, said first camera providing output indicative of a wide field of view;
 - a second camera imaging said area of illumination by said lighting head, said second camera providing output indicative of a magnified narrow field of view; and
 - an electronics module, attached to said luminaire system, and receiving said electronic control signals from the remote controller, and also receiving power, and said electronics module providing power to said first and second cameras, and receiving electronic signals from said first and second cameras indicative of imaging by the first and second cameras, and sending said electronic signals indicative of the imaging by the first and second cameras to the remote controller.
12. The system as in claim 11, wherein said first camera and said second camera are each attached to the lighting head to point in the same direction as a pointing of the light source and the lighting head, in all positions as the lighting head is moved.
13. The system as in claim 11, wherein said first camera and said second camera are each separated from the lighting head.
14. The luminaire as in claim 11, wherein one of said cameras includes an exposure control that irises up and down quickly in order to quickly adjust for varying lighting conditions.
15. The luminaire as in claim 11, wherein said electronic control signals includes at least one camera control signals, which adjust parameters of the camera based on the camera control signals in the electronic control signals.
16. The system as in claim 13, wherein said first camera and said second camera are controlled to move in pan and tilt directions.

* * * * *