



US009004730B2

(12) **United States Patent**
LaVigna et al.

(10) **Patent No.:** **US 9,004,730 B2**
(45) **Date of Patent:** **Apr. 14, 2015**

(54) **INTERLOCKING LIGHTING FIXTURE**

29/004 (2013.01); F21V 29/02 (2013.01); F21V 23/04 (2013.01); F21W 2131/40 (2013.01); F21W 2131/406 (2013.01); F21Y 2101/02 (2013.01); F21Y 2105/001 (2013.01); F21V 29/763 (2015.01)

(71) Applicant: **0Energy Lighting, Inc.**, Farmingdale, NY (US)

(72) Inventors: **David LaVigna**, Orlando, FL (US); **Robert T. Temple**, Orlando, FL (US)

(58) **Field of Classification Search**
CPC F21V 21/30; F21W 2131/406
USPC 362/426
See application file for complete search history.

(73) Assignee: **0Energy Lighting, Inc.**, Farmingdale, NY (US)

(*) Notice: Subject to any disclaimer, the term of this patent is extended or adjusted under 35 U.S.C. 154(b) by 271 days.

(56) **References Cited**

U.S. PATENT DOCUMENTS

4,447,859 A * 5/1984 Raczynski 362/13
4,918,576 A * 4/1990 Farrall et al. 362/11

(Continued)

FOREIGN PATENT DOCUMENTS

WO WO 2010/128440 11/2010 F21S 2/00

OTHER PUBLICATIONS

The Notification of Transmittal of the International Search Report and the Written Opinion of the International Search Authority, or the Declaration; the International Search Report; and the Written Opinion of the International Searching Authority (in English), dated Jan. 22, 2013, issued from Applicants' corresponding PCT Application No. PCT/EP2012/061888 by the International Searching Authority of WIPO.

Primary Examiner — Sean Gramling
(74) *Attorney, Agent, or Firm* — Gerald T. Bodner

(57) **ABSTRACT**

A lighting fixture includes a hexagonal housing having six side walls. Each side wall has a slot formed therein. Two or more lighting fixtures may be joined together to form a modular arrangement of lighting fixtures in a plurality of configurations by using an interlock piece which slides into channels formed in facing side walls of adjacent lighting fixtures to hold the lighting fixtures together.

22 Claims, 29 Drawing Sheets

(21) Appl. No.: **13/660,595**

(22) Filed: **Oct. 25, 2012**

(65) **Prior Publication Data**

US 2013/0155688 A1 Jun. 20, 2013

Related U.S. Application Data

(60) Provisional application No. 61/551,505, filed on Oct. 26, 2011, provisional application No. 61/611,349, filed on Mar. 15, 2012.

(51) **Int. Cl.**

- F21S 8/00** (2006.01)
- F21V 21/00** (2006.01)
- F21S 2/00** (2006.01)
- F21V 21/005** (2006.01)
- F21V 21/30** (2006.01)
- F21V 5/04** (2006.01)
- F21V 29/00** (2006.01)
- F21V 29/02** (2006.01)
- F21V 23/04** (2006.01)
- F21W 131/40** (2006.01)
- F21W 131/406** (2006.01)
- F21Y 101/02** (2006.01)
- F21Y 105/00** (2006.01)

(52) **U.S. Cl.**

CPC **F21V 21/00** (2013.01); **F21S 2/005** (2013.01); **F21V 21/005** (2013.01); **F21V 21/30** (2013.01); **F21V 5/04** (2013.01); **F21V**

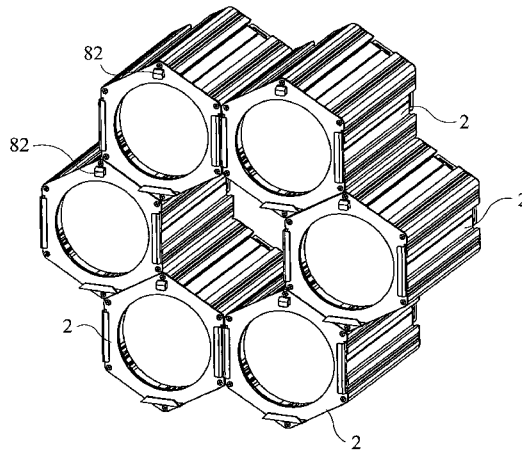

(56)

References Cited

U.S. PATENT DOCUMENTS

6,851,831 B2* 2/2005 Karlicek, Jr. 362/249.06
7,824,073 B2 11/2010 Hsieh et al. 362/249.11
D639,144 S 6/2011 Schaefer et al. D8/354
7,963,669 B2 6/2011 Hockel et al. 362/249.02

2008/0037284 A1 2/2008 Rudisill 362/629
2009/0010026 A1 1/2009 Gai 362/609
2009/0097242 A1* 4/2009 Hsieh et al. 362/234
2009/0154156 A1 6/2009 Lo et al. 362/234
2011/0045704 A1 2/2011 Li et al. 439/638

* cited by examiner

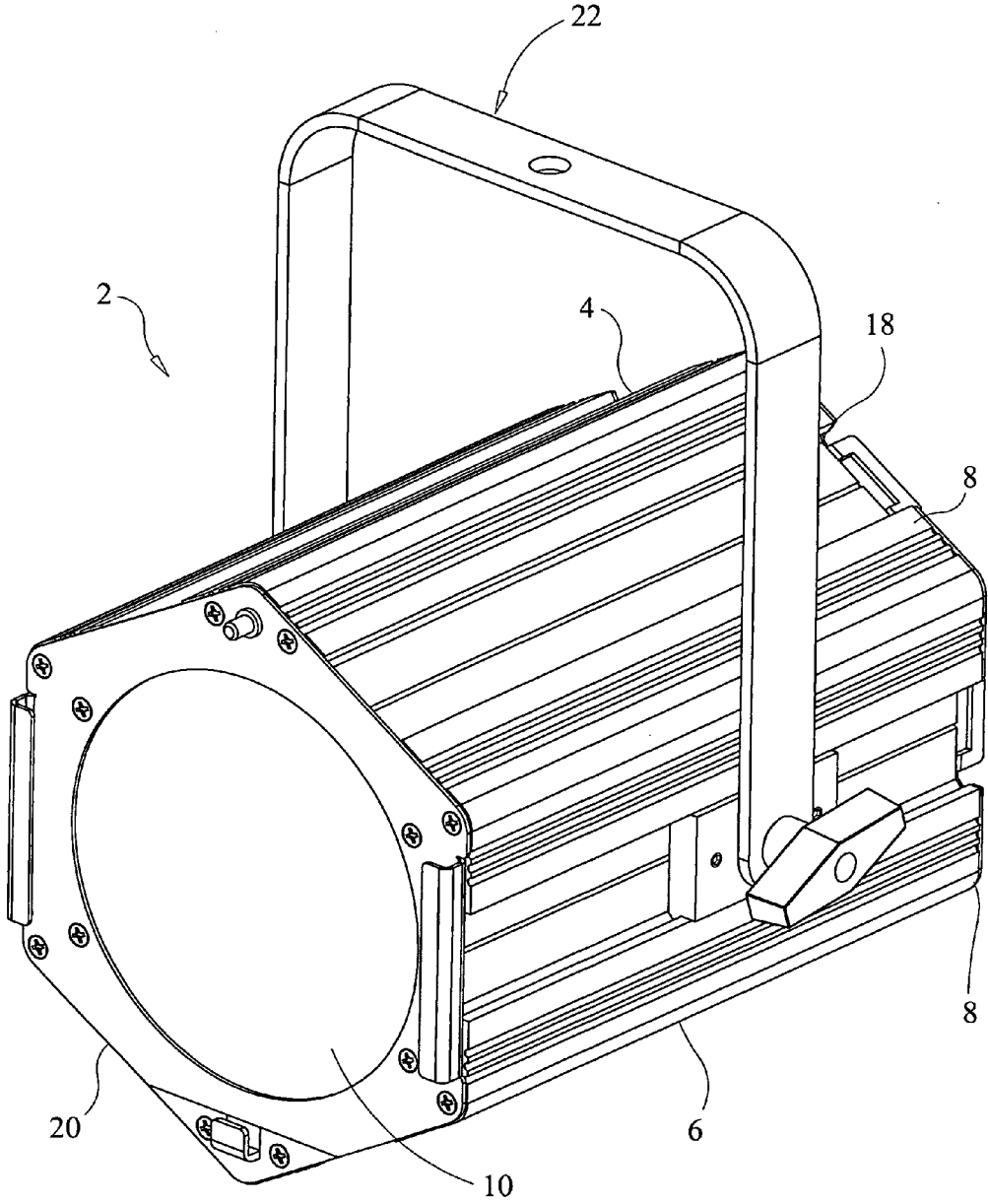

FIG. 1

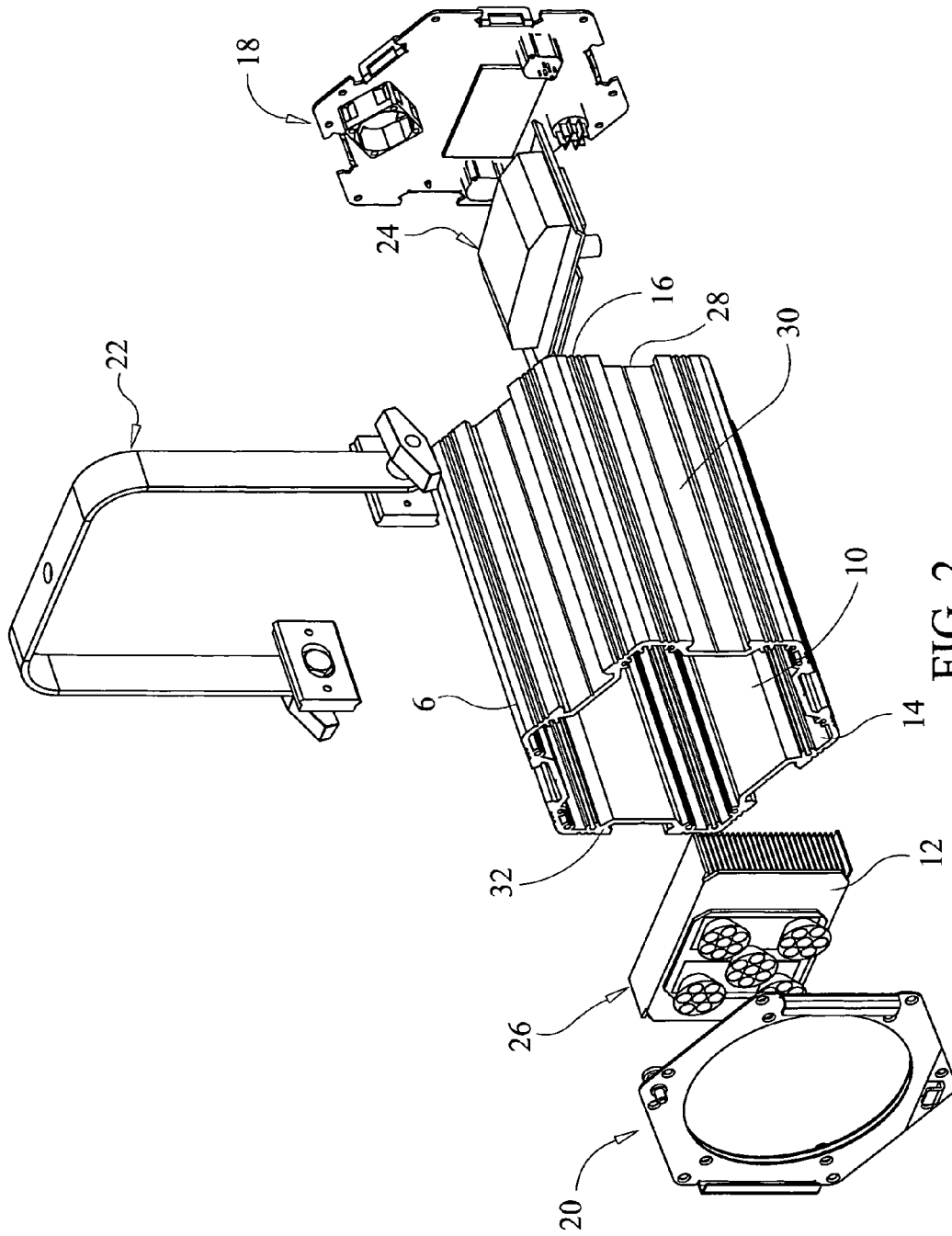

FIG. 2

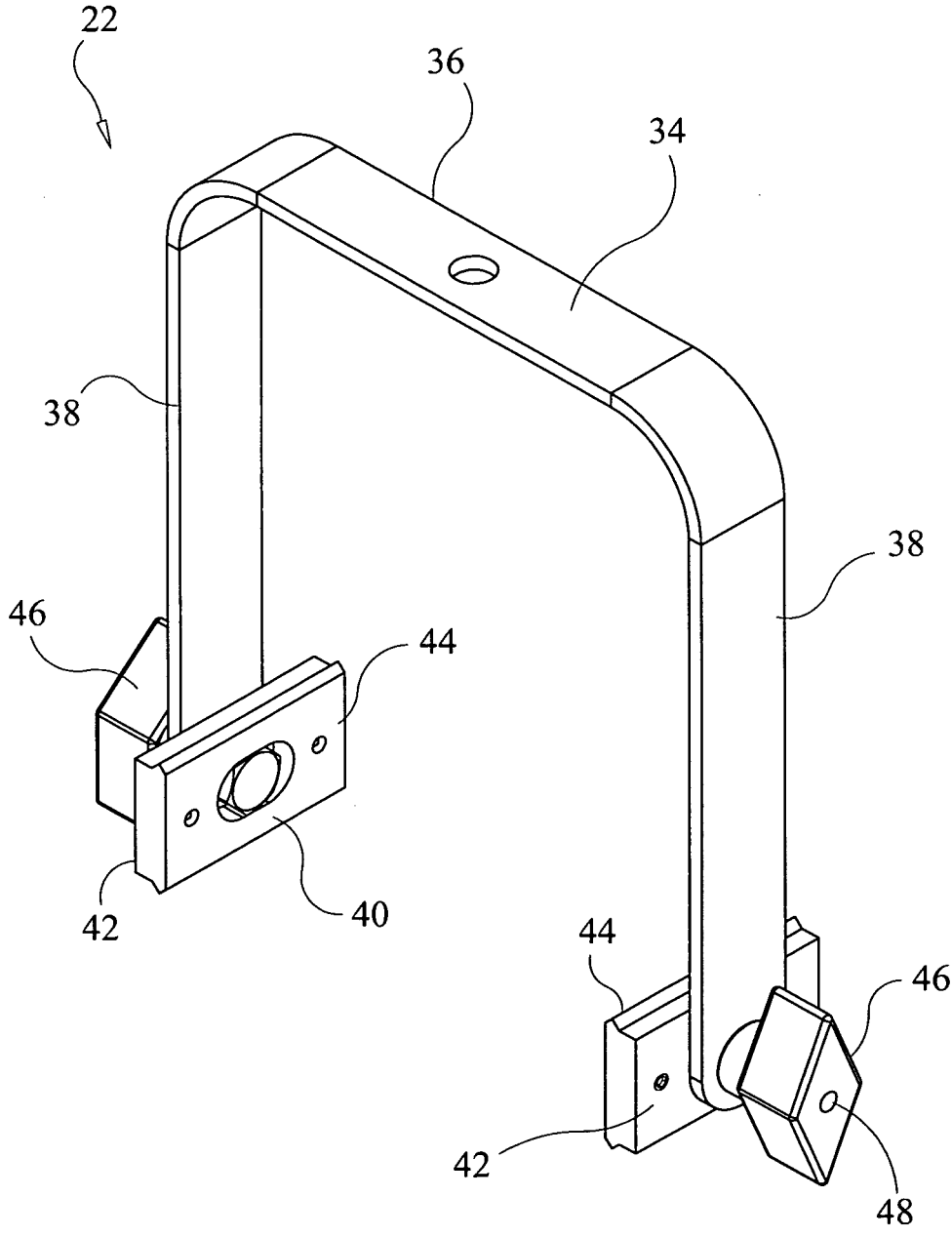

FIG. 3

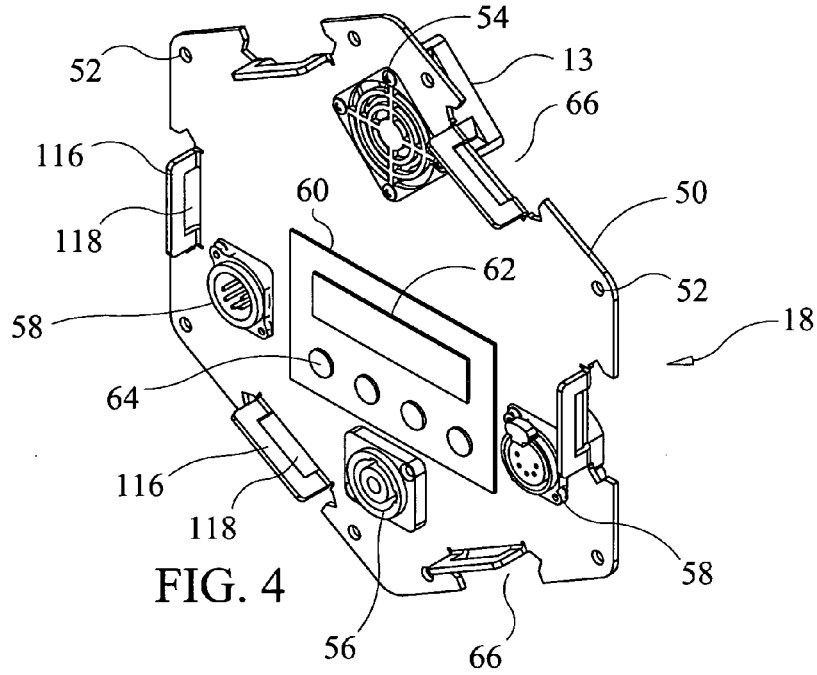

FIG. 4

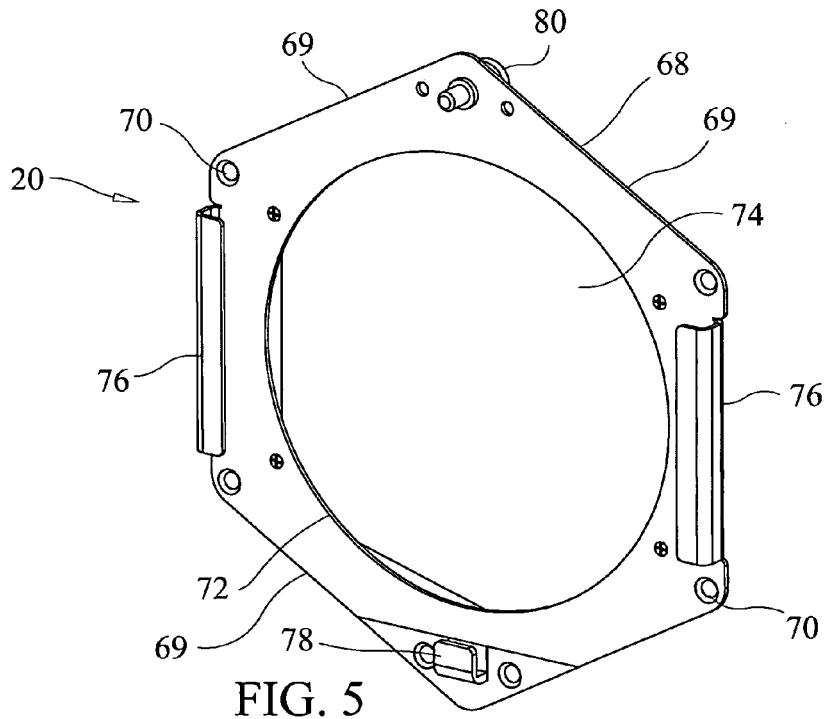

FIG. 5

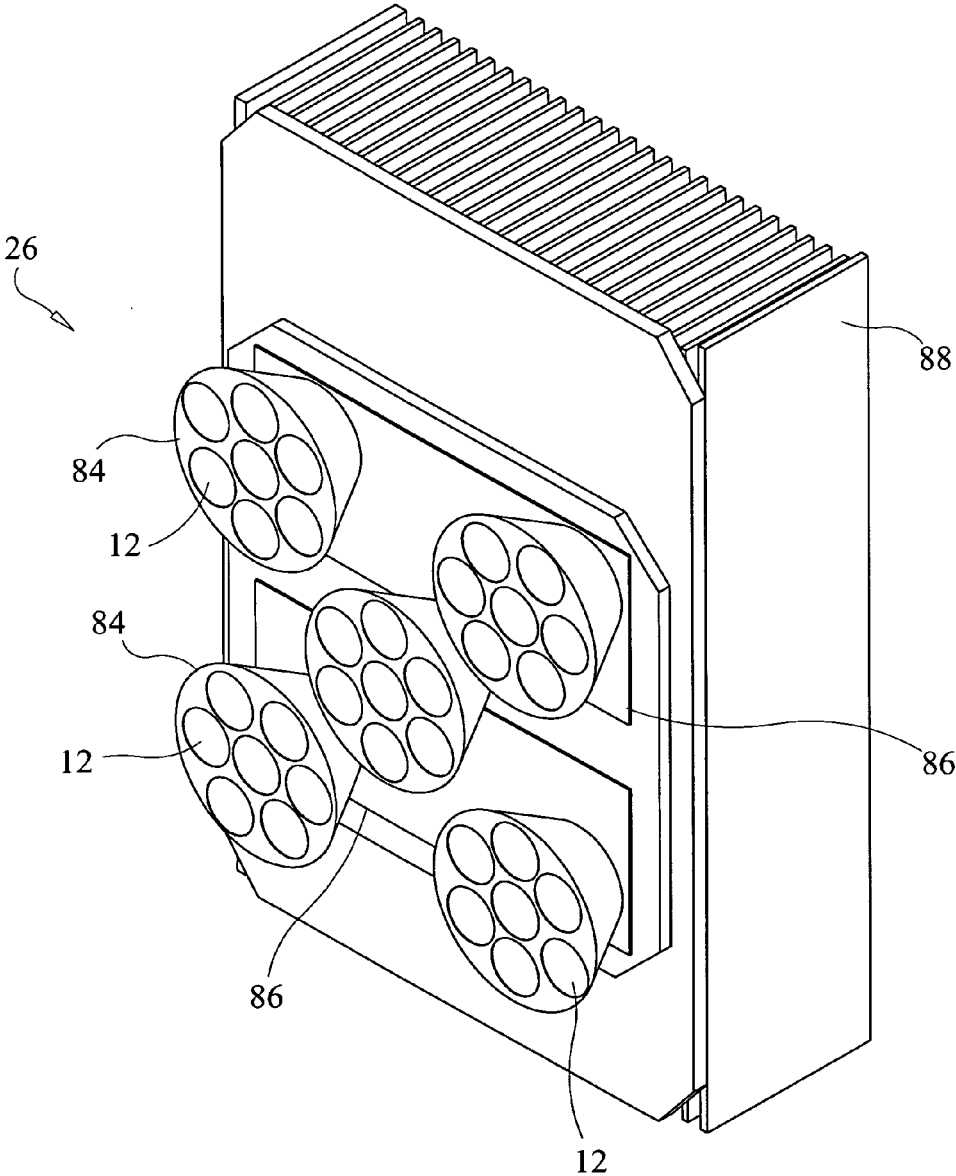

FIG. 6

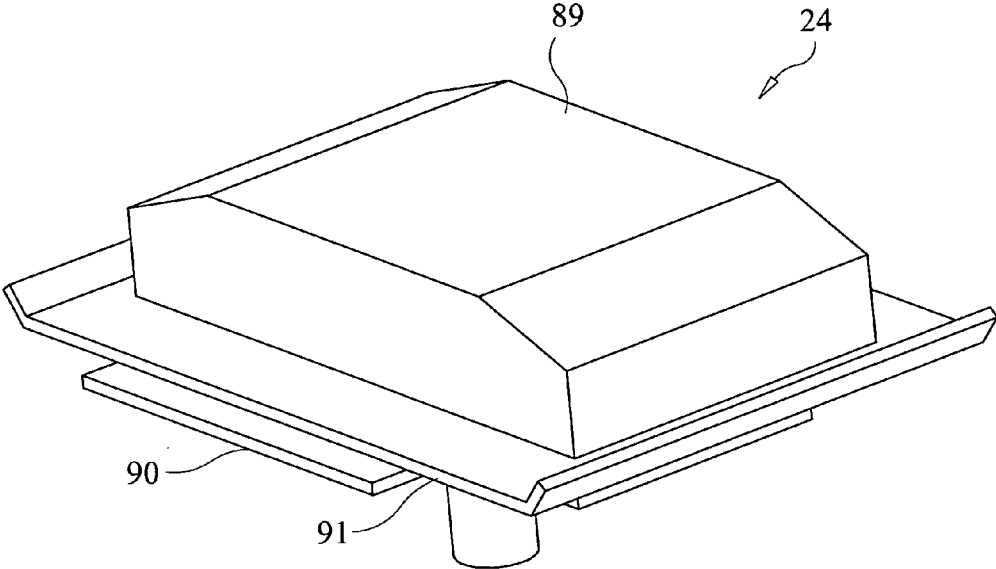

FIG. 7

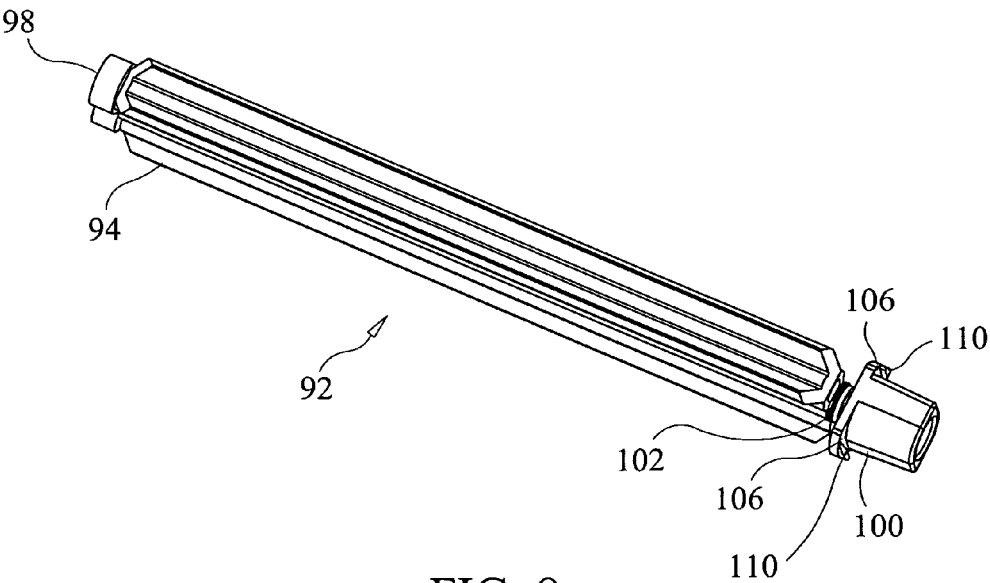

FIG. 8

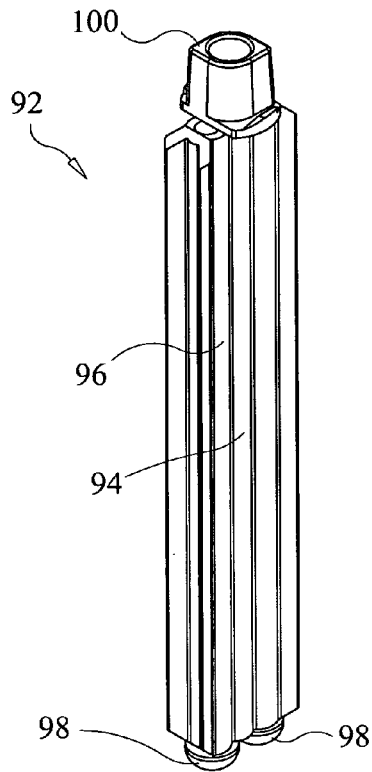

FIG. 8a

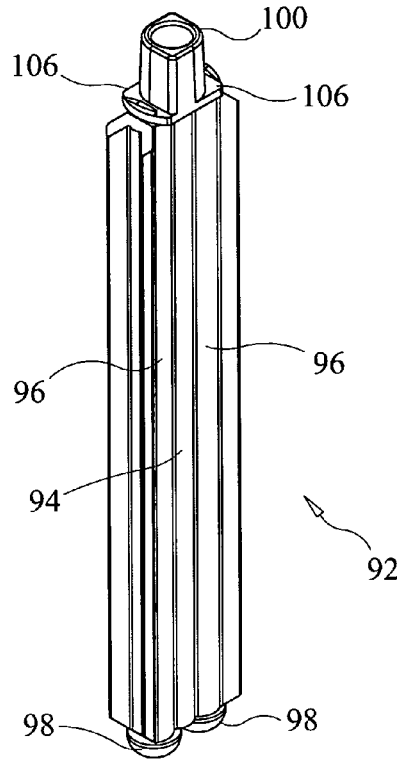

FIG. 8b

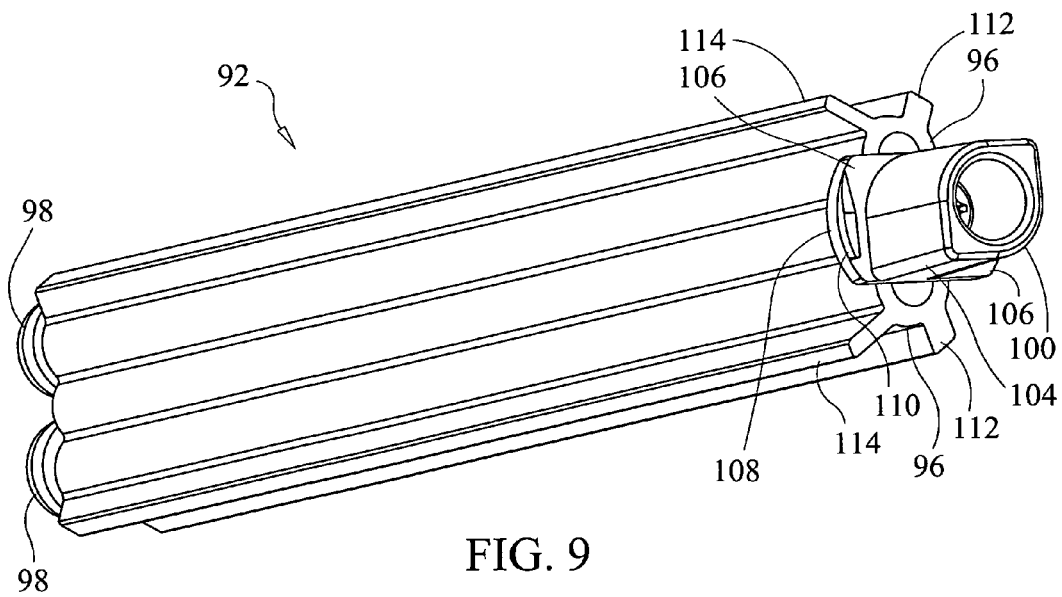

FIG. 9

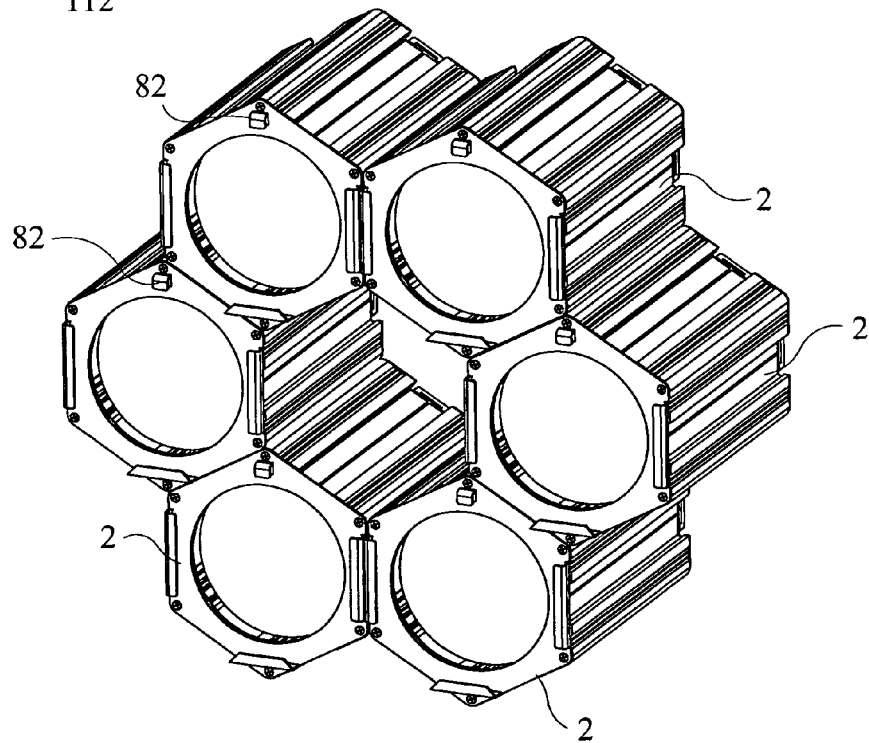
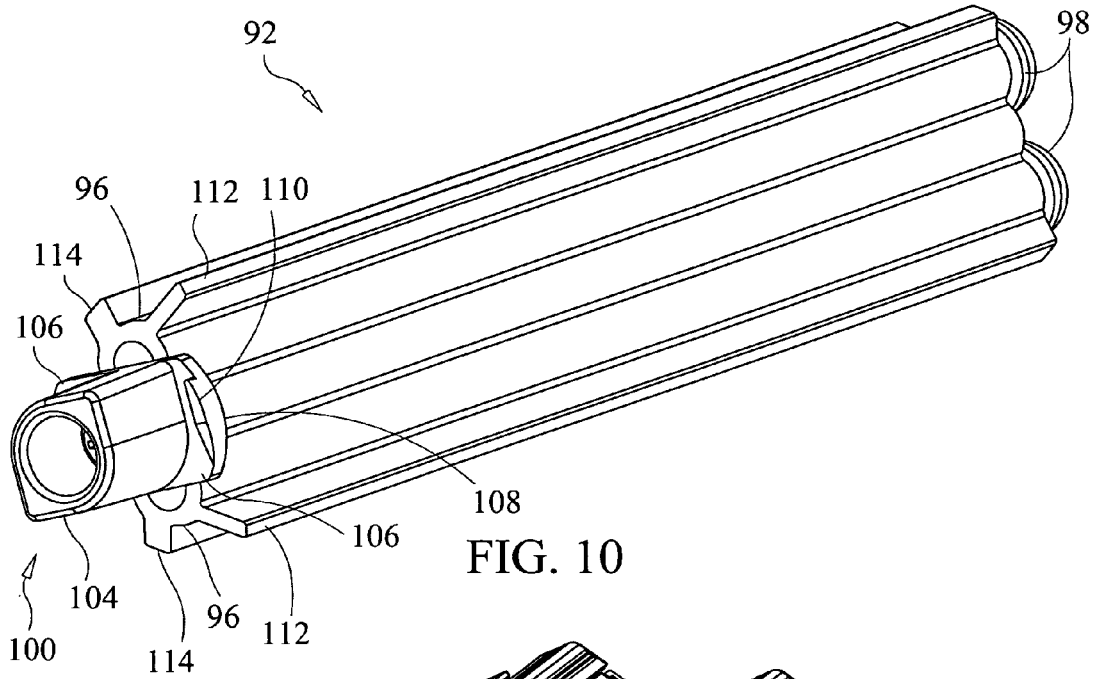

FIG. 11

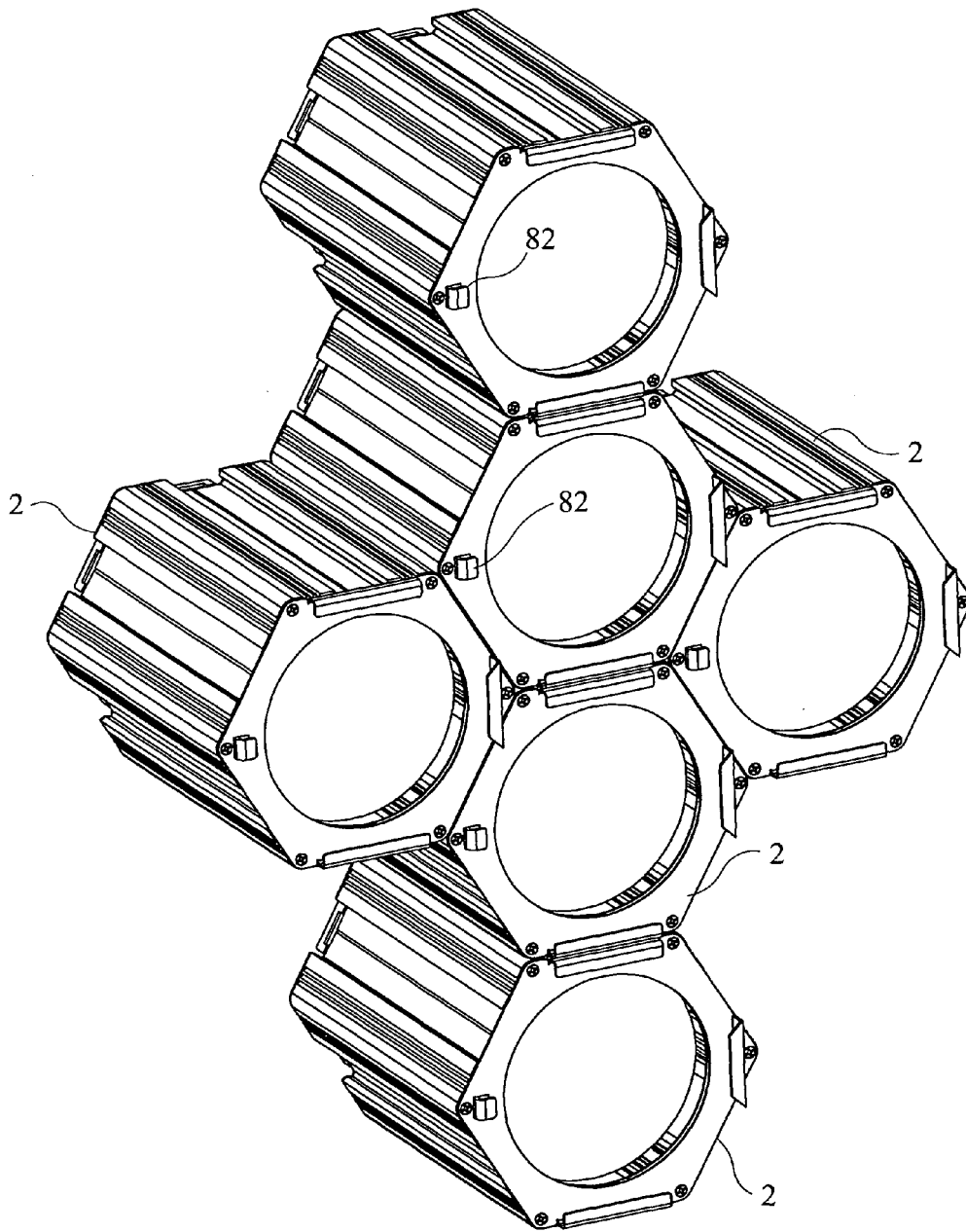

FIG. 12

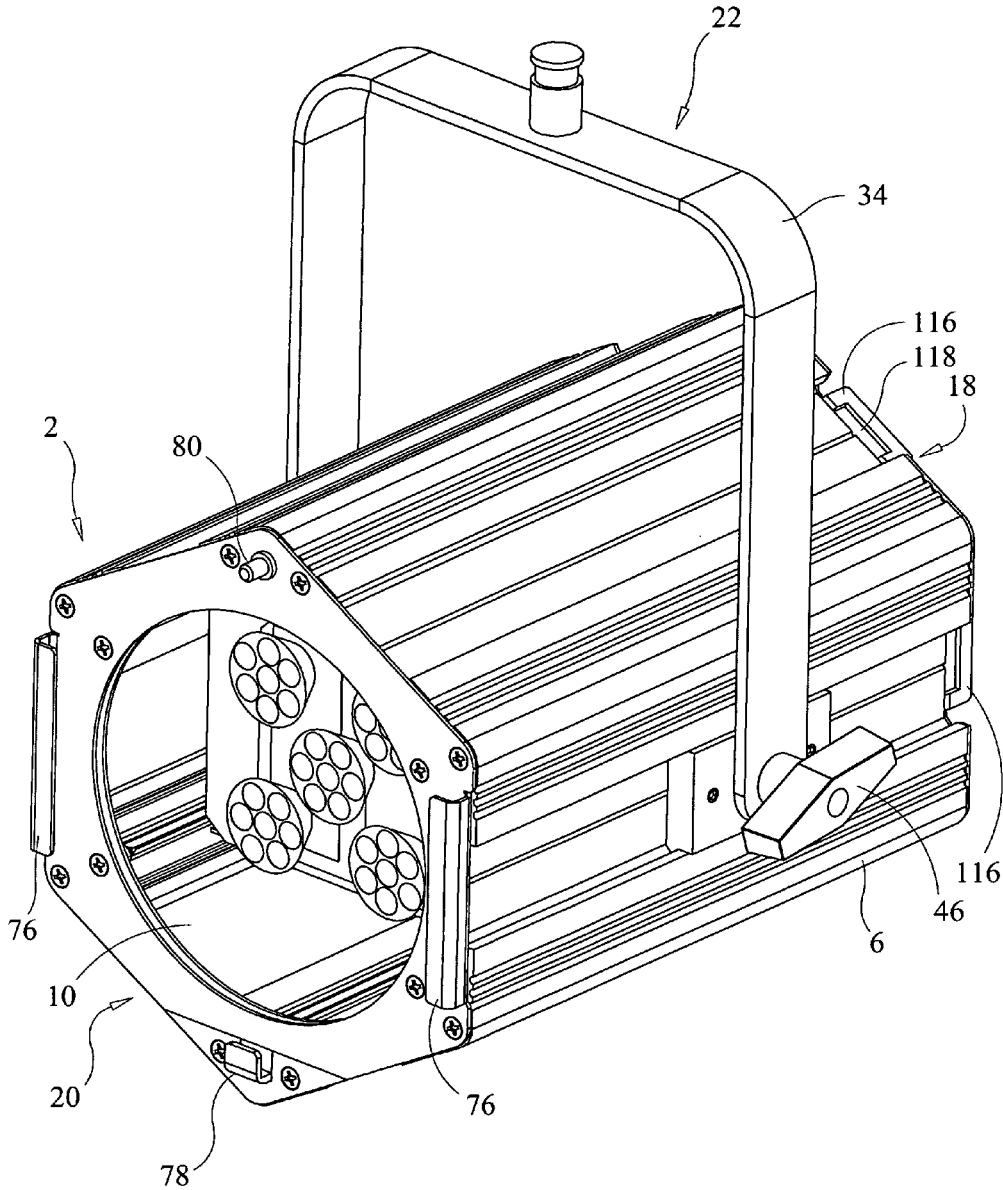

FIG. 13

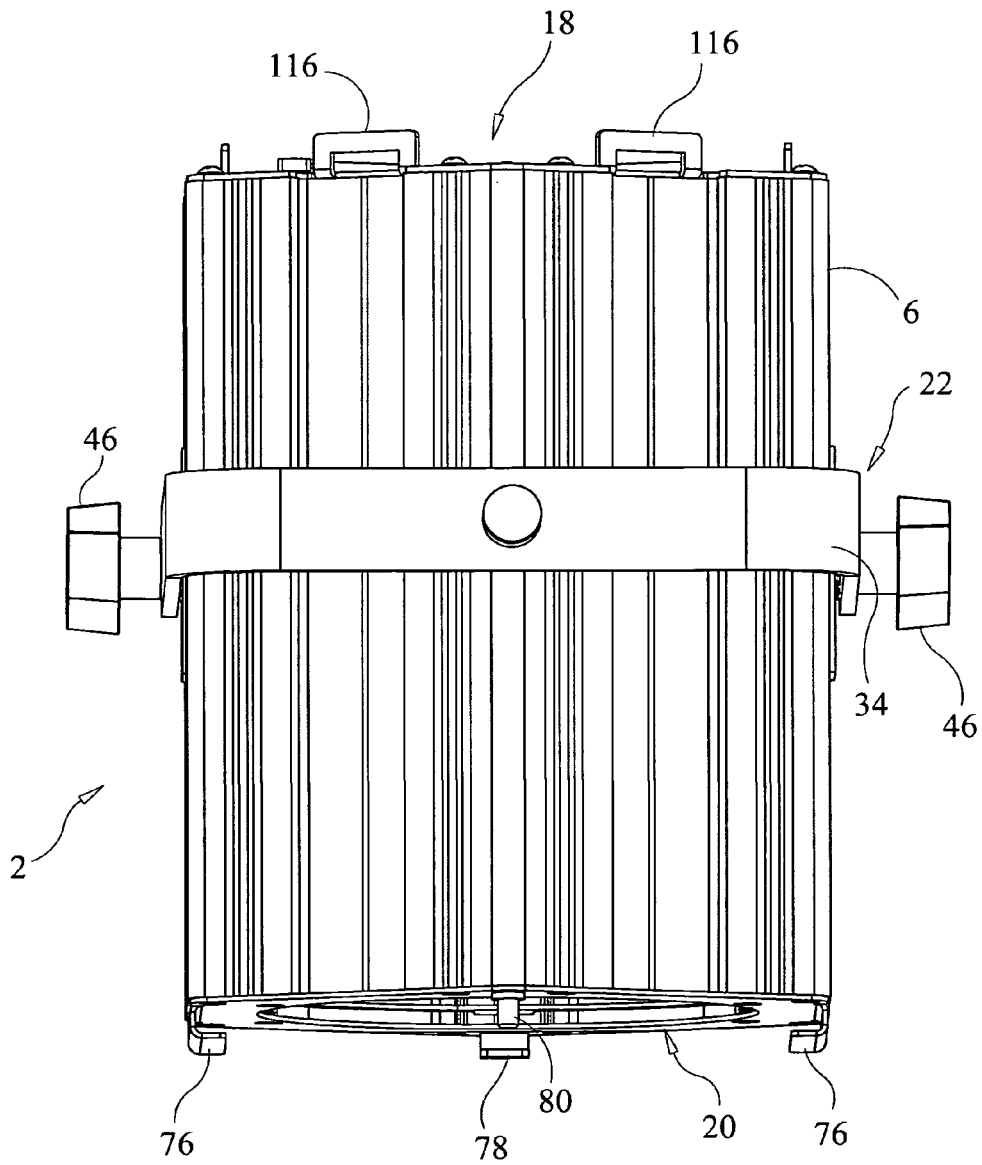

FIG. 14

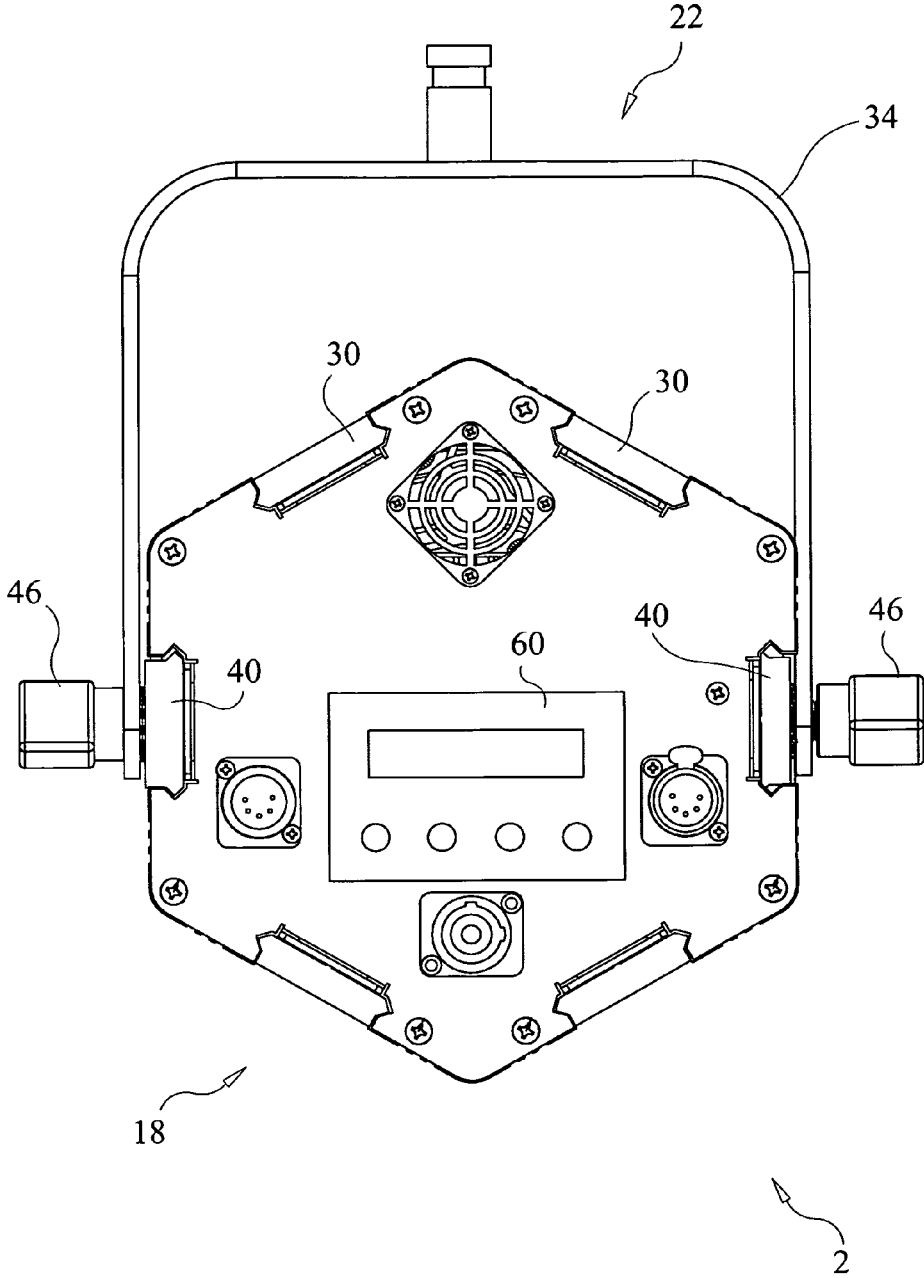

FIG. 15

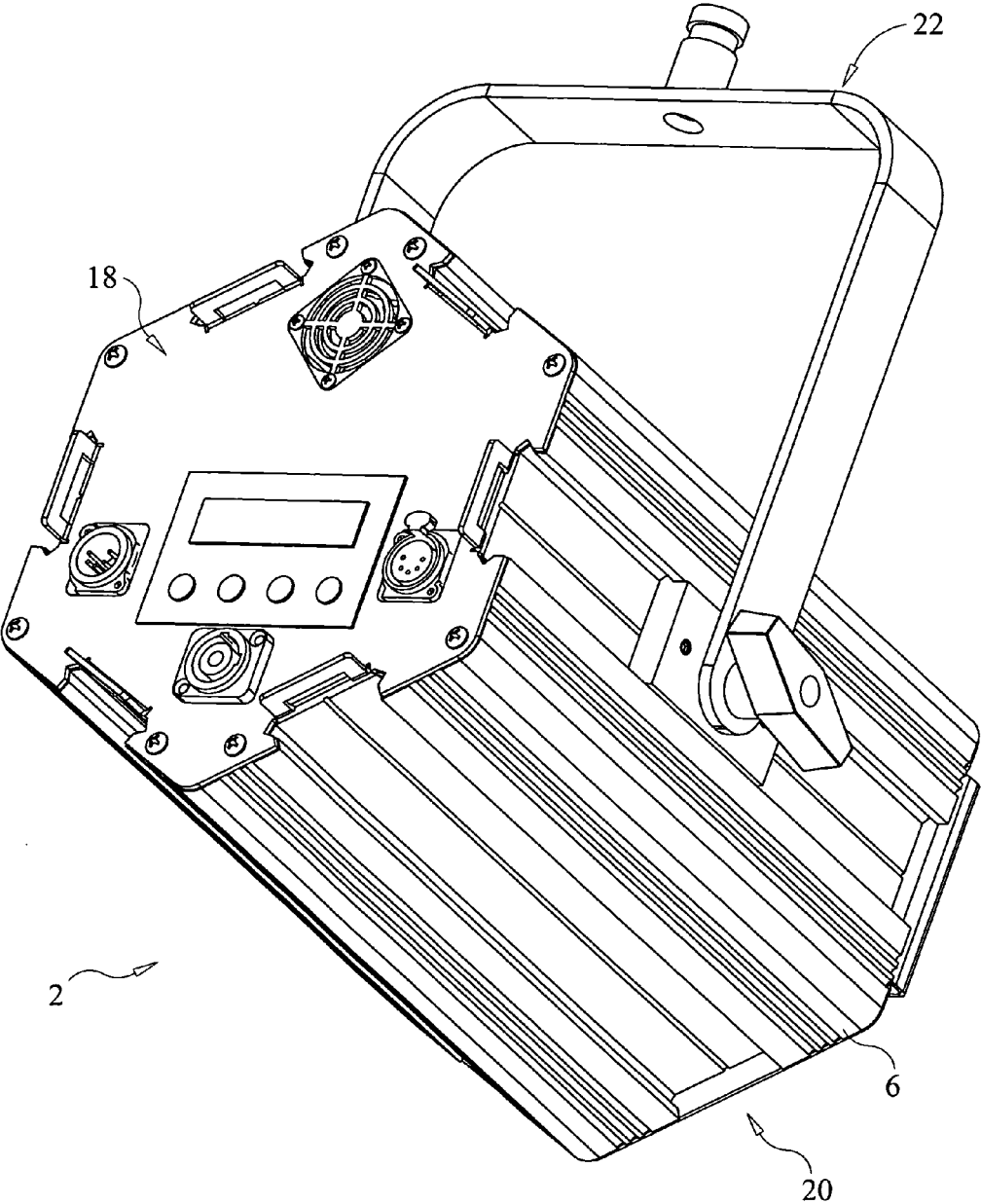

FIG. 16

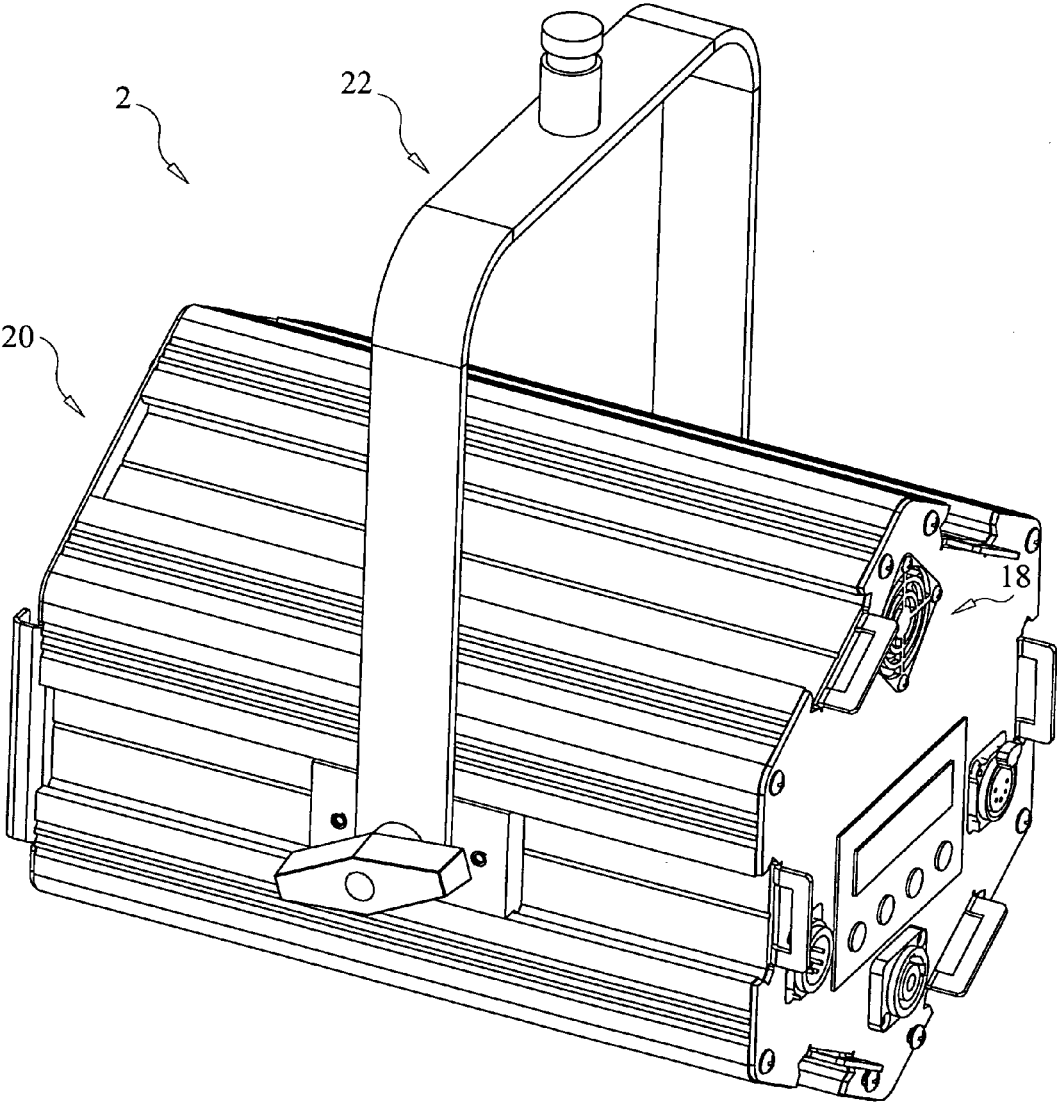

FIG. 17

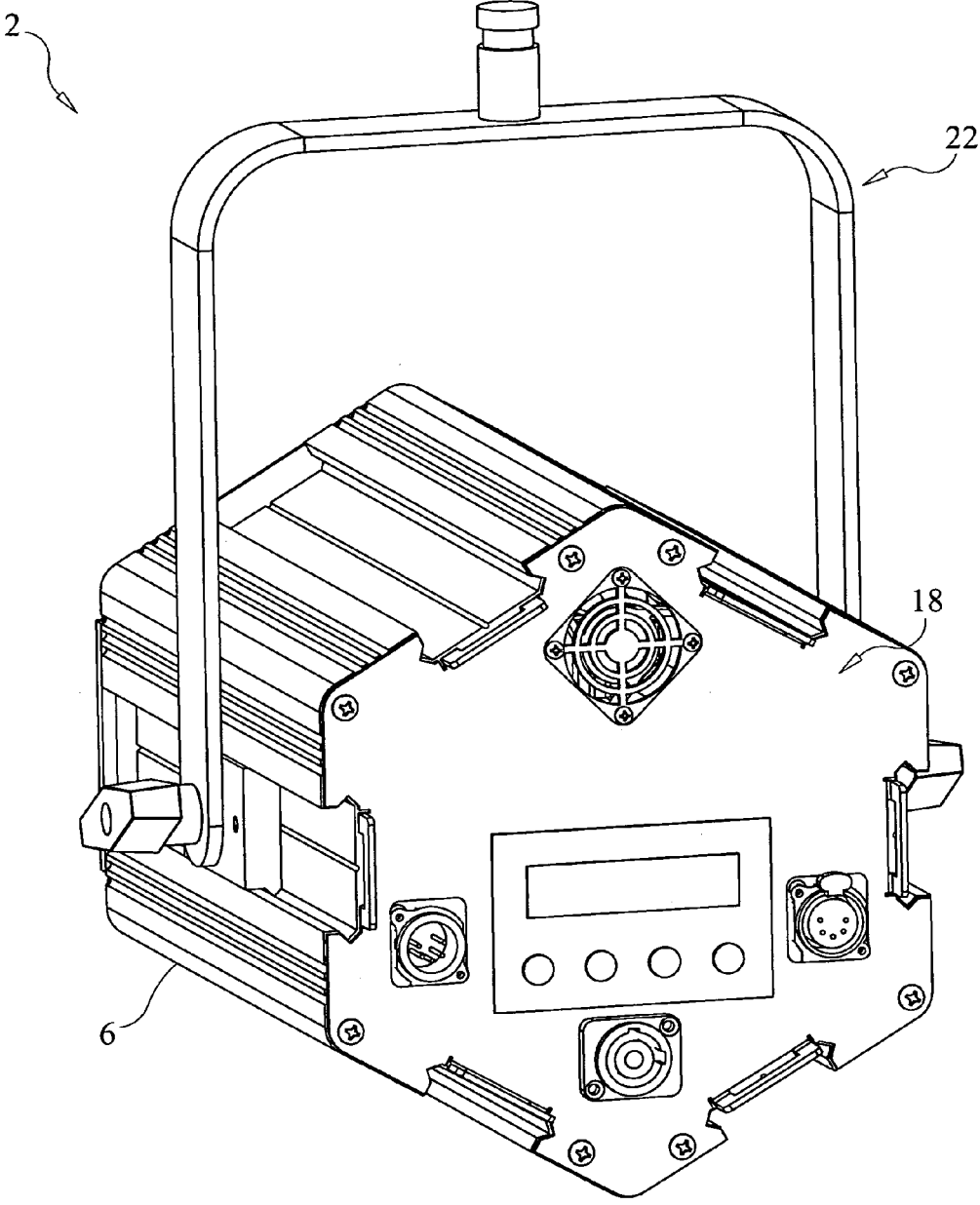

FIG. 18

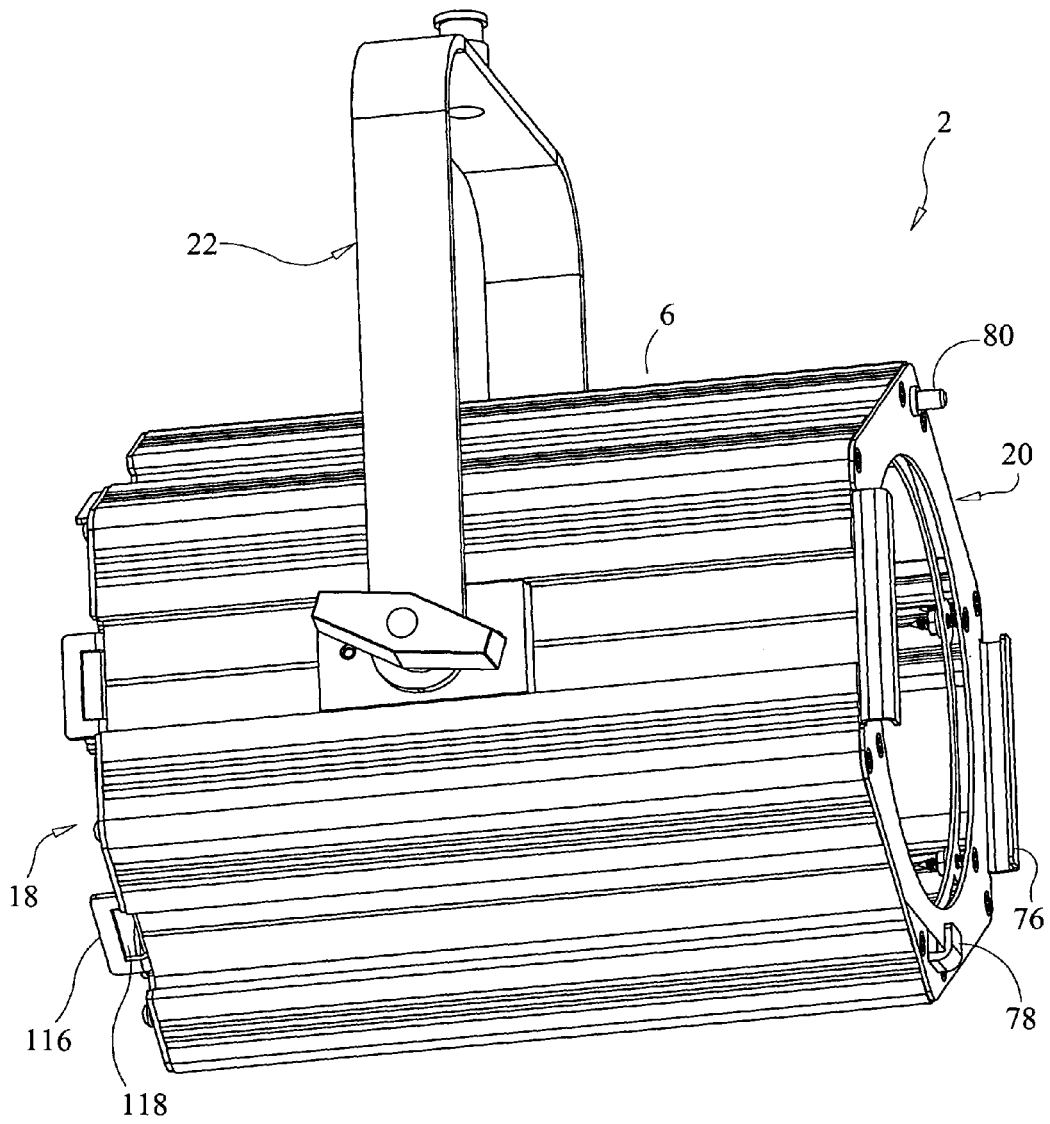

FIG. 19

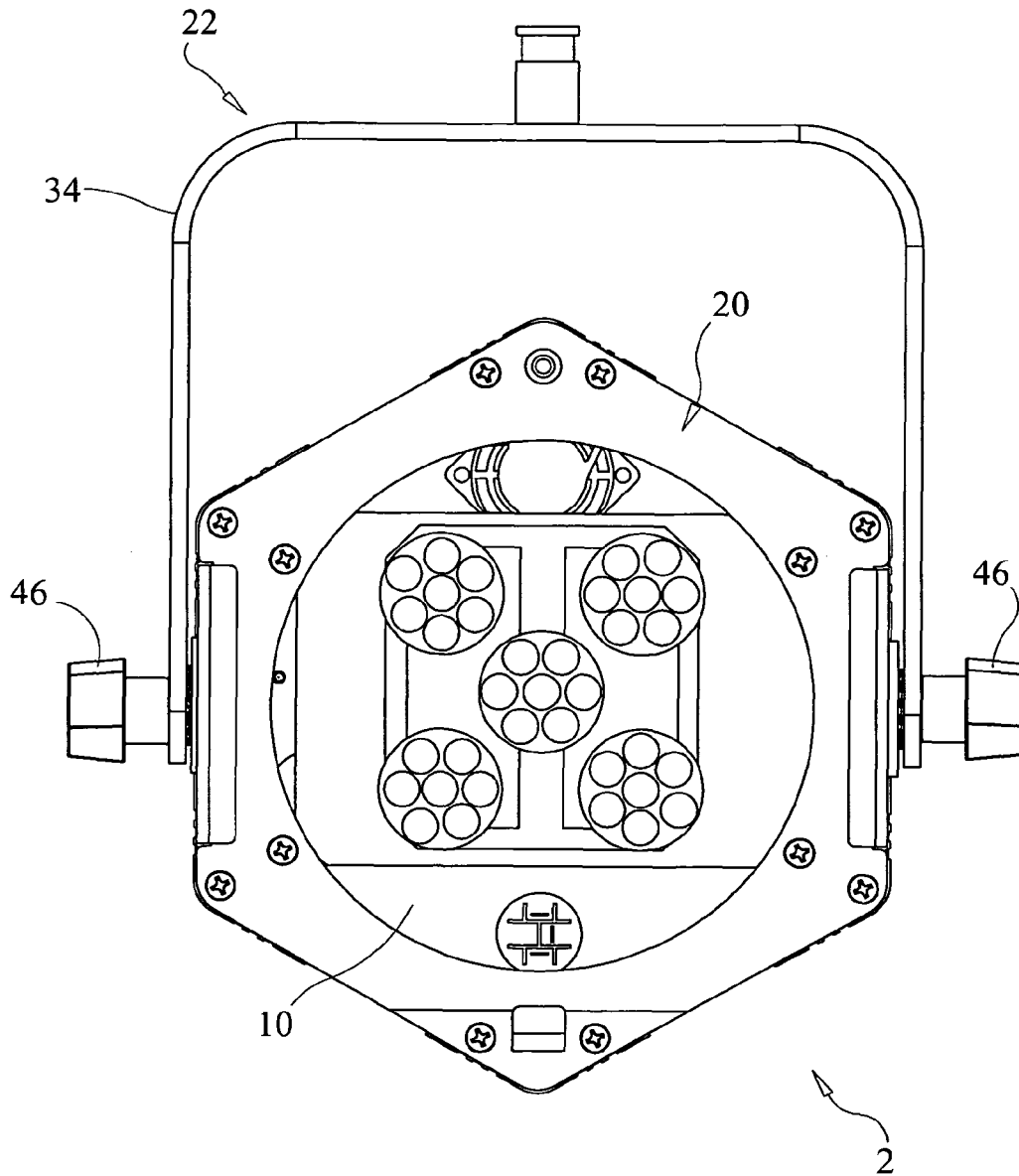

FIG. 20

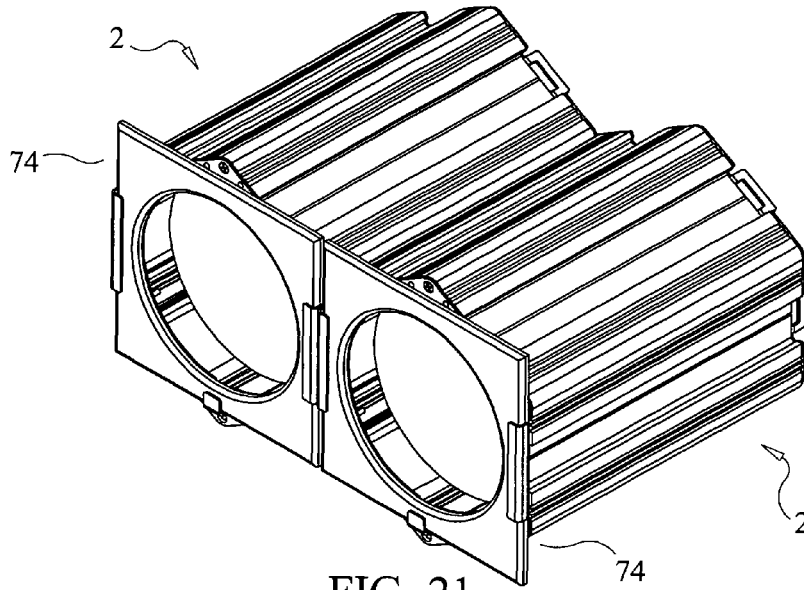

FIG. 21

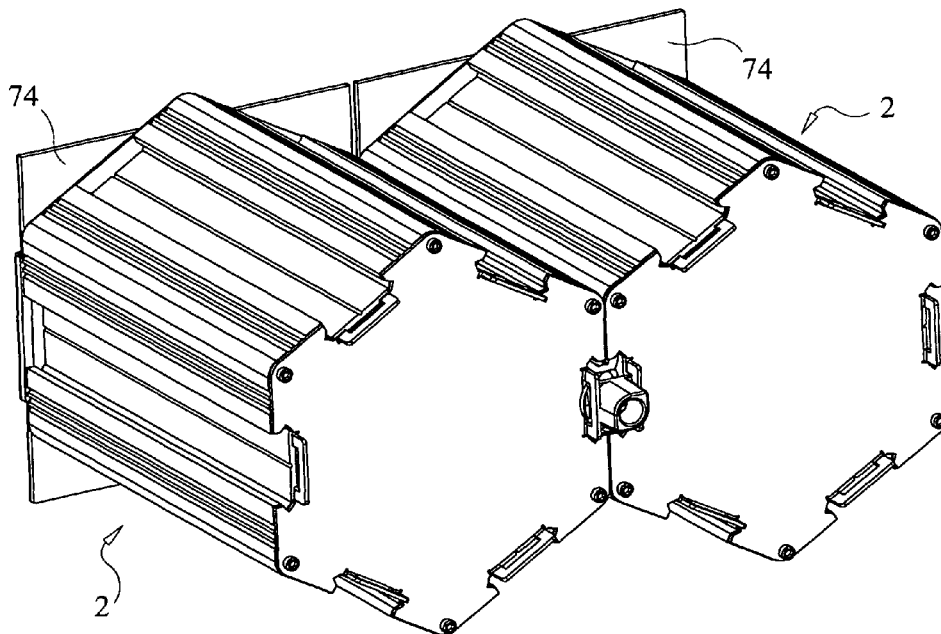

FIG. 22

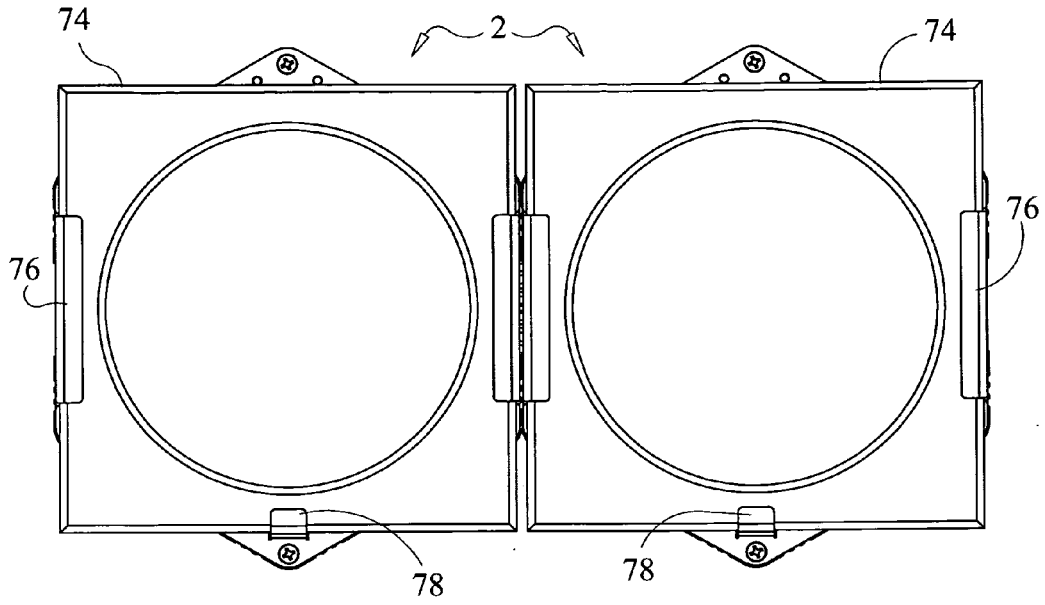

FIG. 23

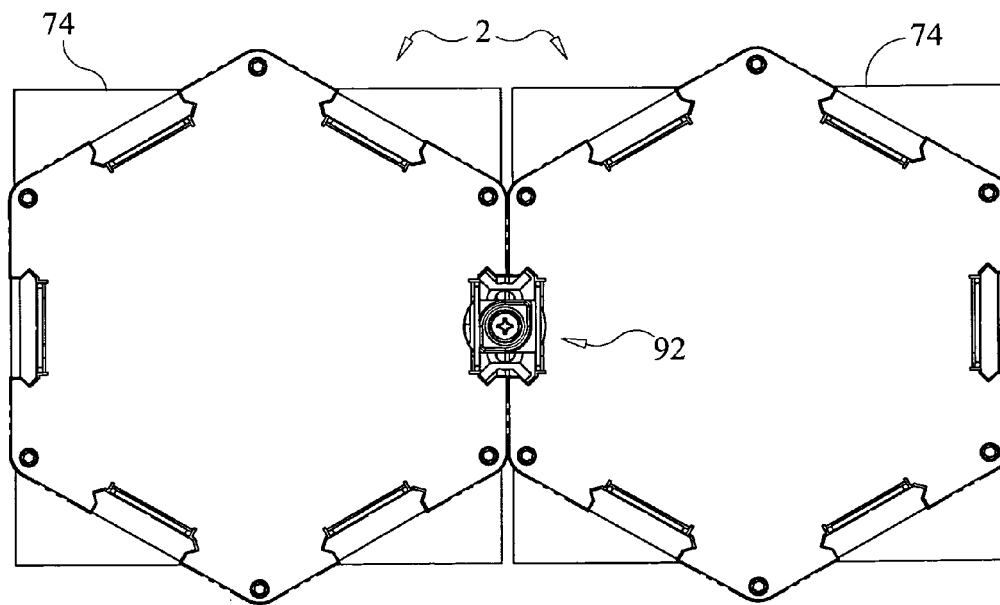

FIG. 24

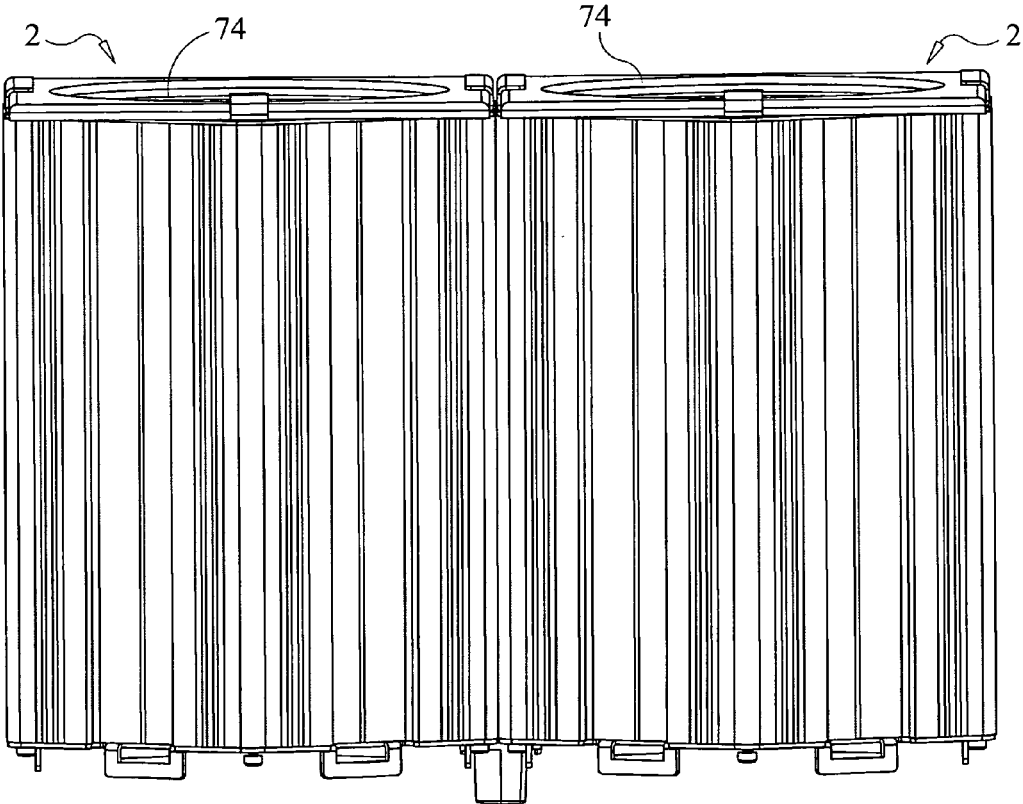

FIG. 25

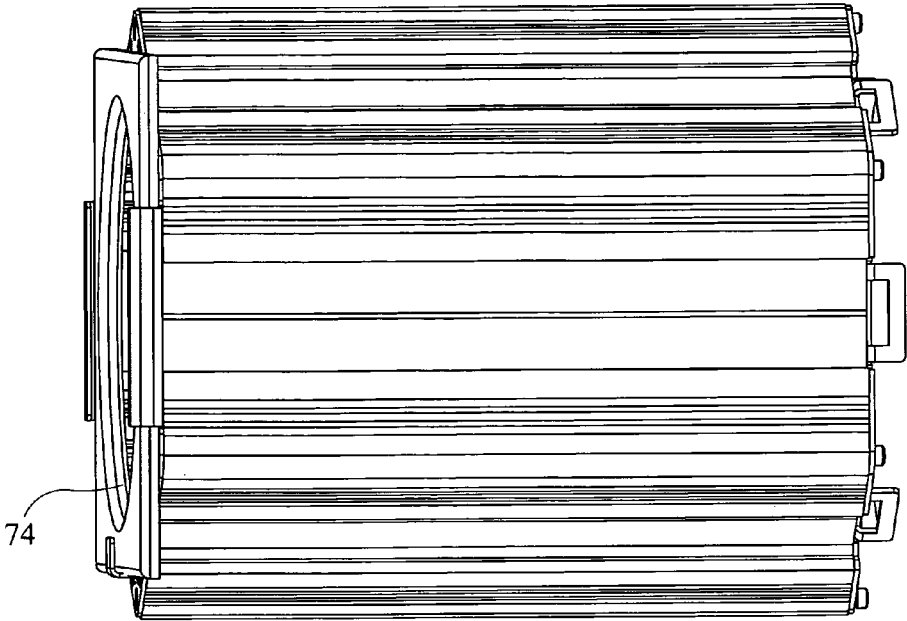

FIG. 26

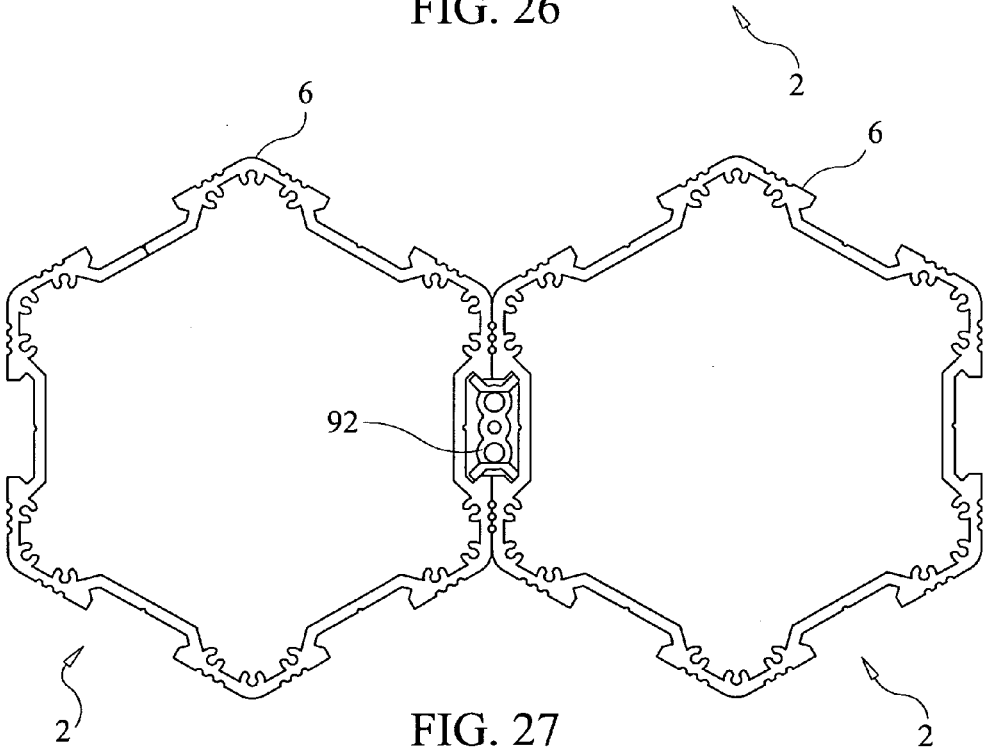

FIG. 27

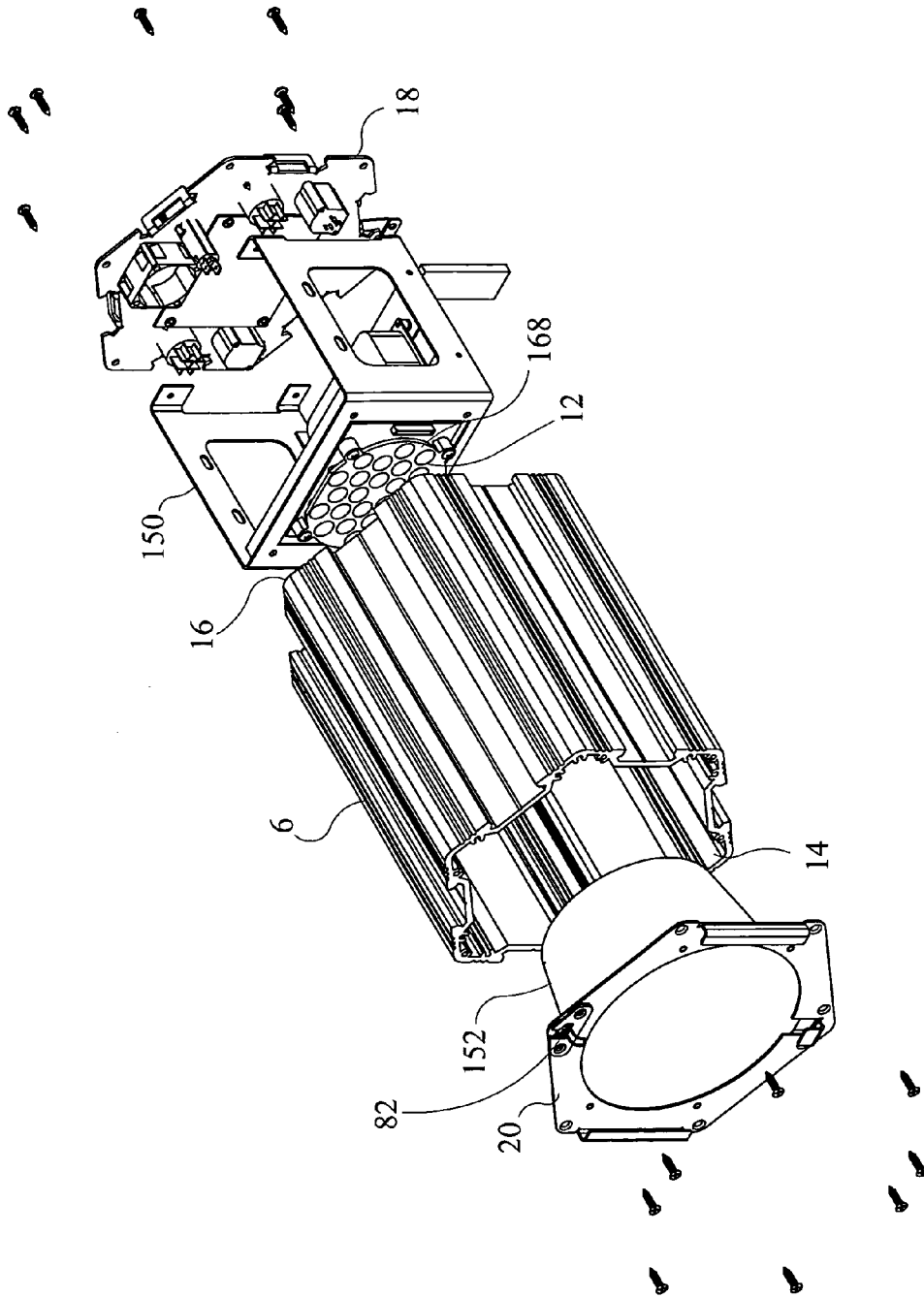

FIG. 28

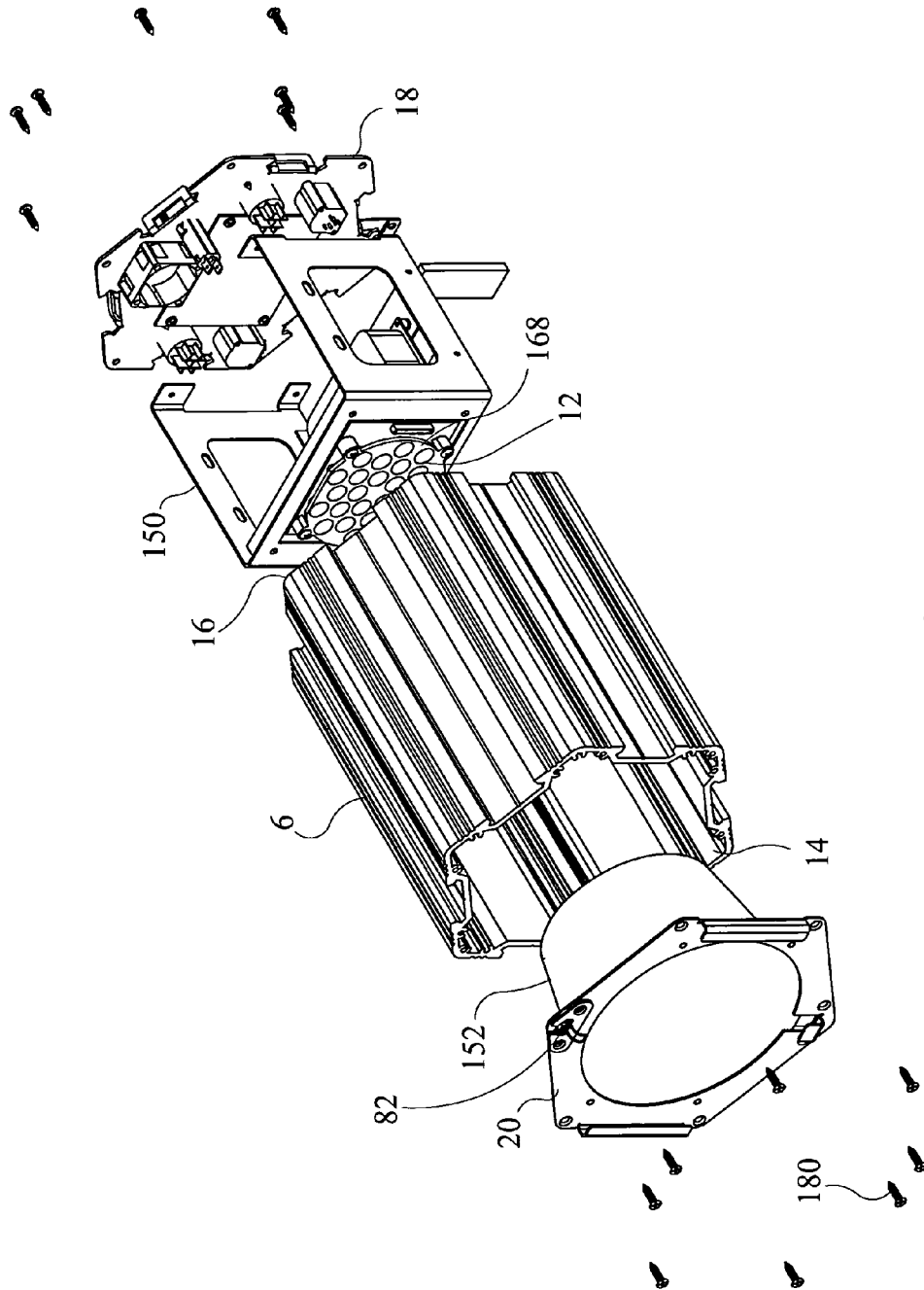

FIG. 29

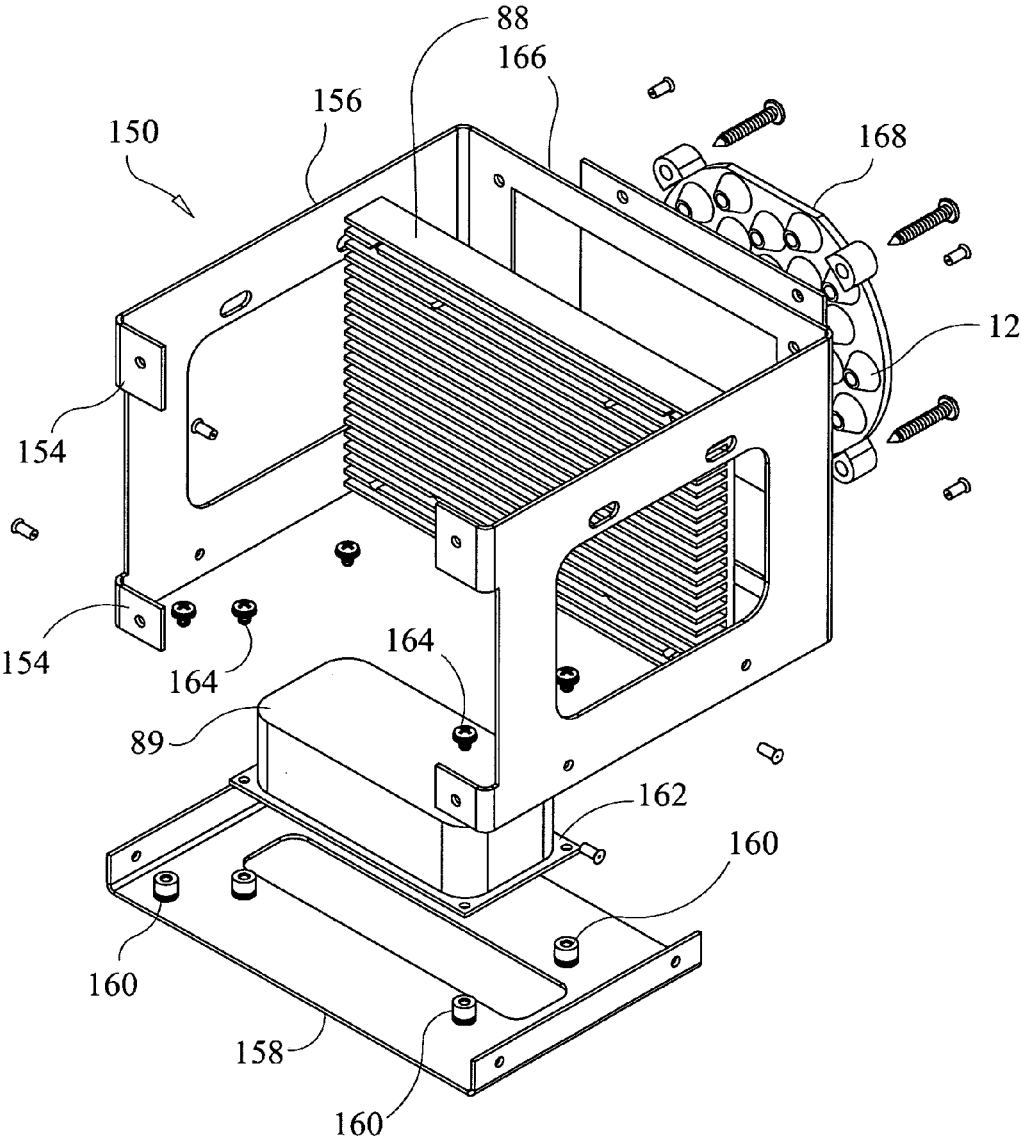

FIG. 30

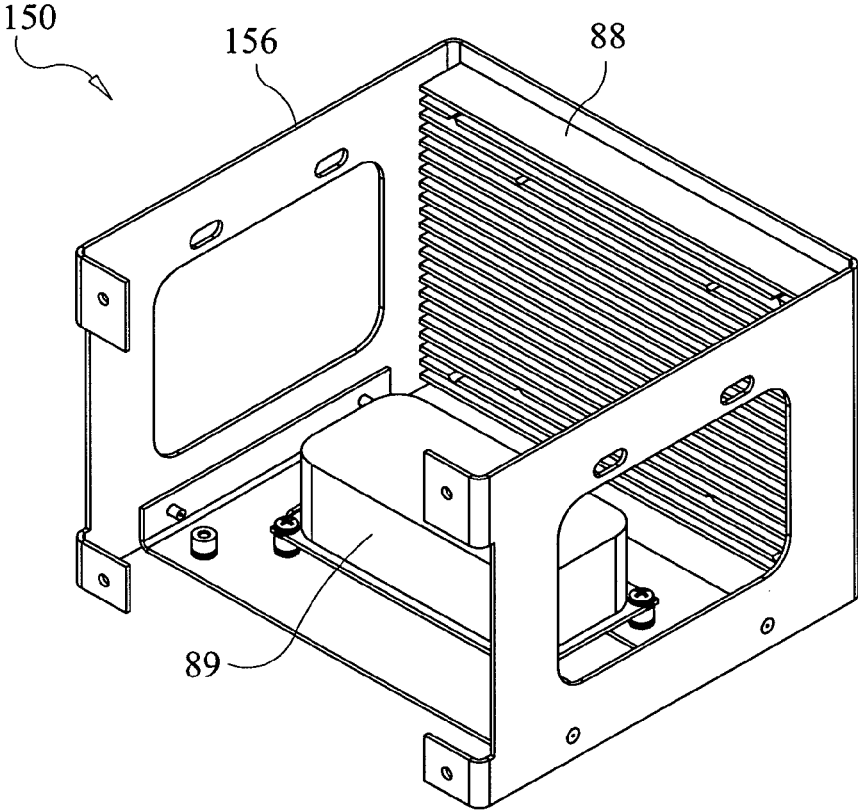

FIG. 31

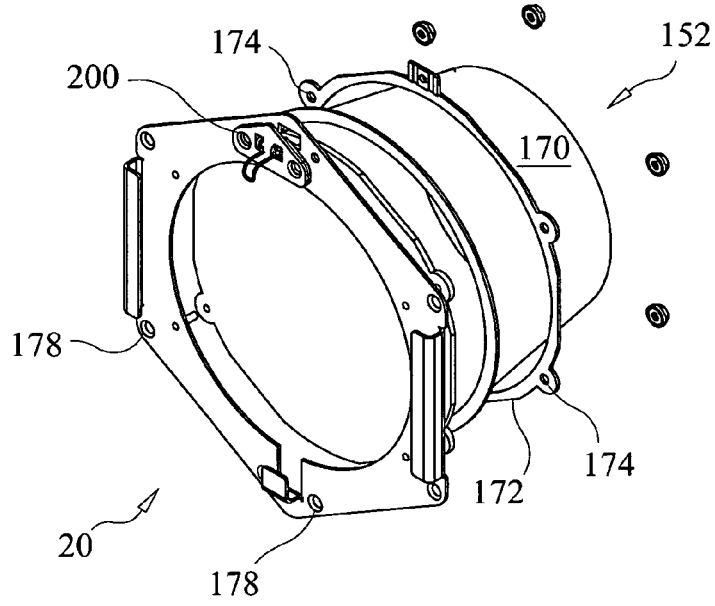

FIG. 32

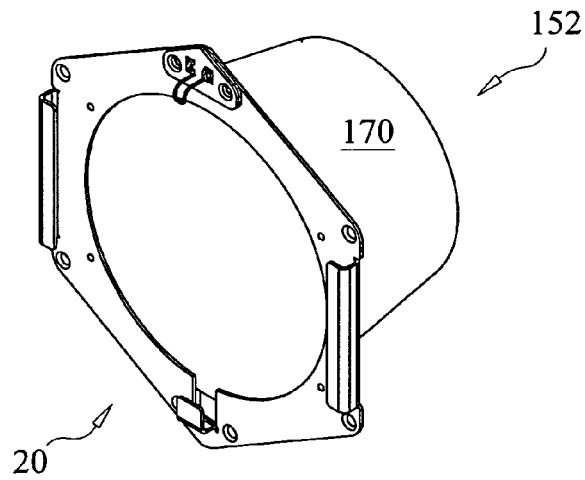

FIG. 33

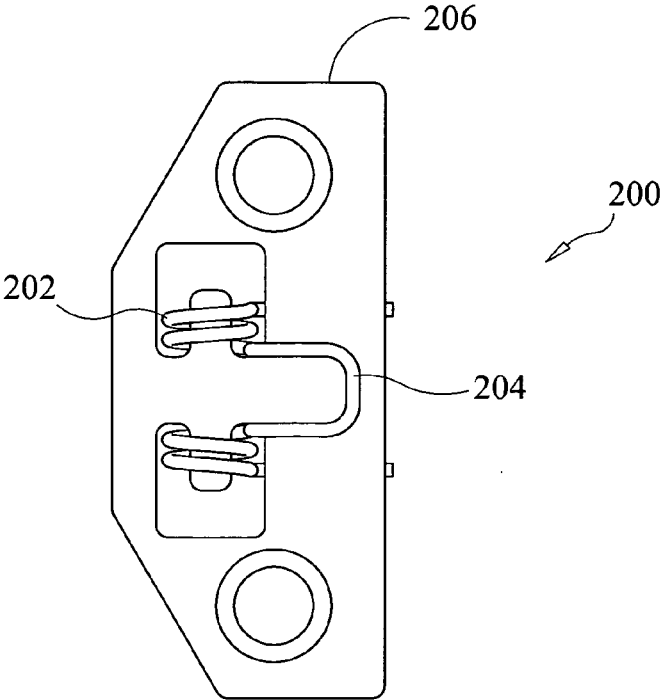

FIG. 34

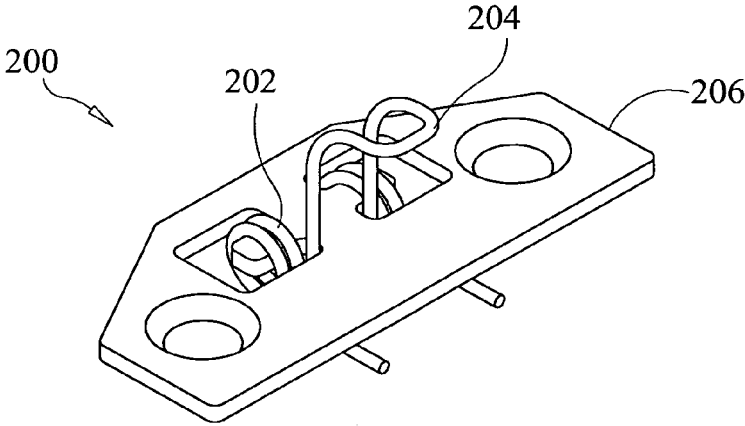

FIG. 35

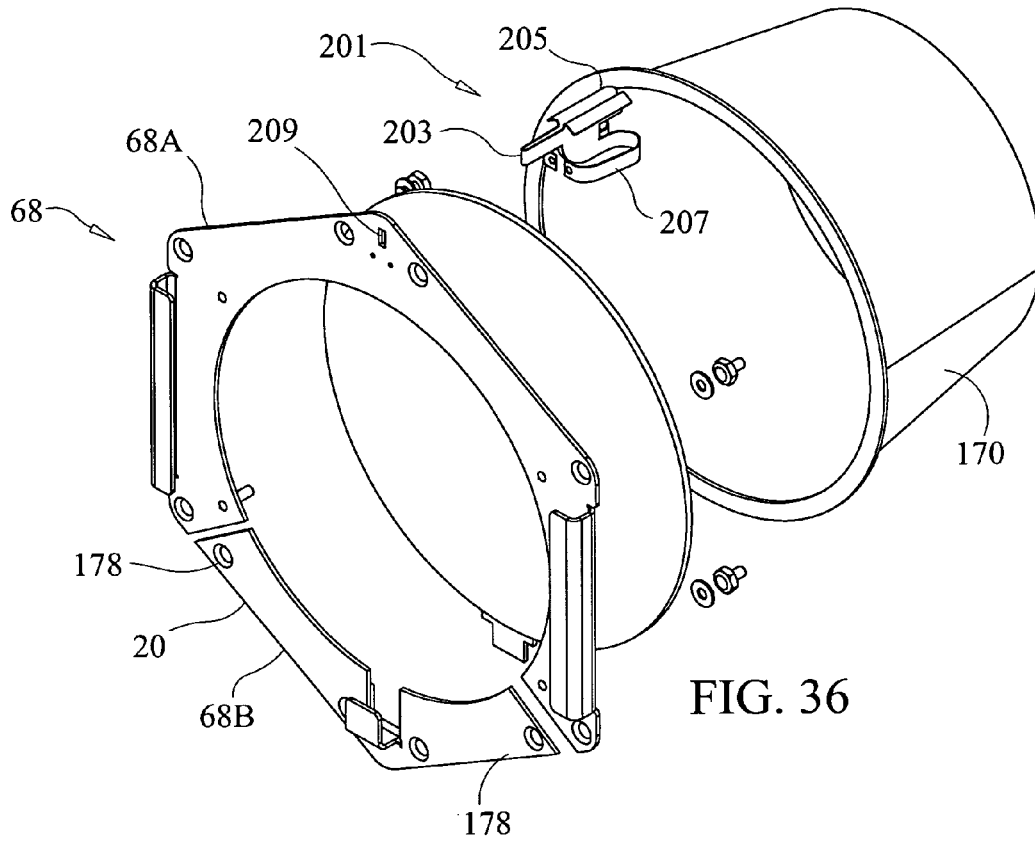

FIG. 36

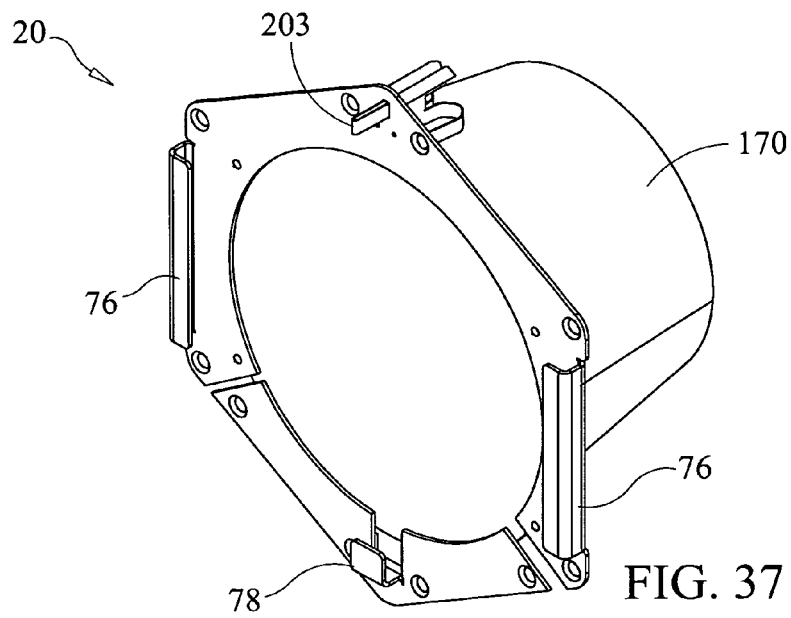

FIG. 37

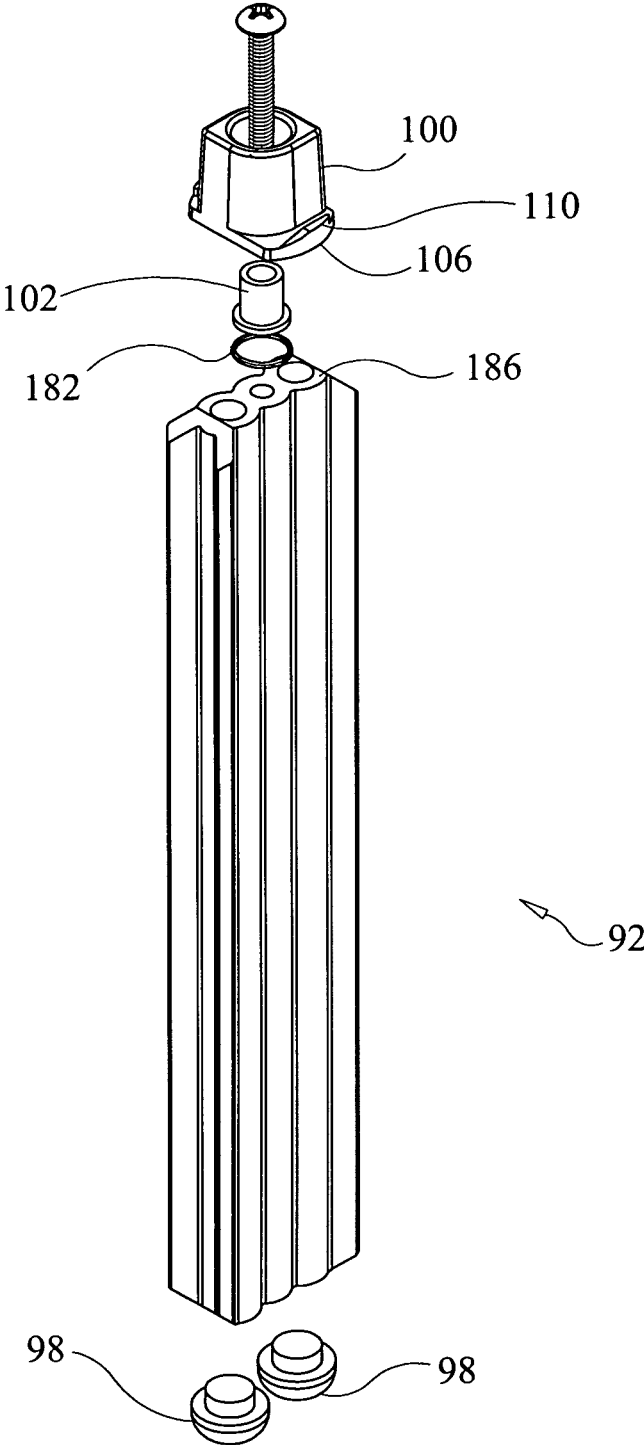

FIG. 38

INTERLOCKING LIGHTING FIXTURE**CROSS-REFERENCE TO RELATED APPLICATIONS**

This application is related to U.S. Provisional Application Ser. No. 61/551,505, filed on Oct. 26, 2011, and entitled "Interlocking Lighting Fixture", and U.S. Provisional Application Ser. No. 61/611,349, filed on Mar. 15, 2012, and also entitled "Interlocking Lighting Fixture", the disclosure of each of which is incorporated herein by reference and on which priority is hereby claimed.

BACKGROUND OF THE INVENTION**1. Field of the Invention**

The present invention generally relates to lighting fixtures, and more specifically relates to lighting fixtures used for commercial, industrial and stage lighting.

2. Description of the Prior Art

Certain lighting fixtures used for commercial, industrial or stage lighting are generally stand-alone products which are individually suspended from a ceiling or mounted to a wall or floor. Each fixture must be individually directed or aimed to illuminate a desired object. Even if such conventional individual lighting fixtures are mounted on a common support, such as an elongated bar, the configurations in which such lighting fixtures may be arranged are limited.

OBJECTS AND SUMMARY OF THE INVENTION

It is an object of the present invention to provide a lighting fixture which may be arranged with other similarly structured lighting fixtures in a plurality of configurations.

It is another object of the present invention to provide a lighting fixture which has the capability of supporting other lighting fixtures attached thereto.

It is still another object of the present invention to provide a lighting fixture having a housing which is directly mountable to the housing of a similarly structured lighting fixture.

It is a further object of the present invention to provide a lighting fixture which has a polygonally-shaped housing, each side wall of the housing having the capability of interlocking with a side wall of a similarly polygonally-shaped lighting fixture to form a modular arrangement of lighting fixtures, where each fixture of the modular arrangement may be replaced, combined or interchanged easily with another lighting fixture.

It is yet a further object of the present invention to provide a modular arrangement of interlocking lighting fixtures in which the modular arrangement may be easily reconfigured as desired.

It is still a further object of the present invention to provide a lighting fixture having interlocking features which overcome the inherent disadvantages of conventional, non-interlocking lighting fixtures.

In one form of the present invention, a lighting fixture is constructed with a housing that has an overall polygonal shape, such as hexagonal, to define a plurality of generally planar side walls. The housing defines an interior space in which is mounted one or more light emitting devices, such as incandescent bulbs or light emitting diodes (LEDs), or plasma LEDs and plasma-based illumination systems, which may emit light at different wavelengths (e.g., blue, red or green), and electronic circuitry for controlling the illumination of the light emitting devices. Each side wall of the

polygonally-shaped housing includes structure which allows it to be connected to the generally planar side wall of another similarly structured lighting fixture. An interlock piece may be used to join the two lighting fixtures together at their adjacent side walls. The interlock piece preferably is received by the cooperating structure situated on the facing side walls of adjacent lighting fixtures to join the two lighting fixtures together. Interlock pieces may also be used on other side walls of the lighting fixtures which have been joined together to add additional lighting fixtures and to thereby form a modular arrangement of lighting fixtures in a variety of configurations. The interlock piece or pieces may be removed to separate the lighting fixtures so that the lighting fixtures may be reconfigured in a different modular arrangement.

These and other objects, features and advantages of the present invention will be apparent from the following detailed description of illustrative embodiments thereof, which is to be read in connection with the accompanying drawings.

BRIEF DESCRIPTION OF THE DRAWINGS

FIG. 1 is perspective view of a lighting fixture formed in accordance with the present invention.

FIG. 2 is a partially exploded, perspective view of the lighting fixture of the present invention shown in FIG. 1.

FIG. 3 is a perspective view of a hanger assembly forming part of the lighting fixture of the present invention.

FIG. 4 is a perspective view of a rear plate assembly forming part of the lighting fixture of the present invention.

FIG. 5 is a perspective view of a front plate assembly forming part of the lighting fixture of the present invention.

FIG. 6 is a perspective view of an assembly containing light emitting devices forming part of the lighting fixture of the present invention.

FIG. 7 is a perspective view of an electronics module forming part of the lighting fixture of the present invention.

FIG. 8 is a perspective view of an interlock piece formed in accordance with the present invention and used to interconnect adjacent lighting fixtures of the present invention.

FIGS. 8a and 8b are perspective views of the interlock piece formed in accordance with the present invention and used to interconnect adjacent lighting fixtures of the present invention, and illustrating the interlock piece in a locked position (FIG. 8a) and an unlocked position (FIG. 8b).

FIG. 9 is another perspective view of the interlock piece formed in accordance with the present invention and used to interconnect adjacent lighting fixtures of the present invention.

FIG. 10 is yet another perspective view of the interlock piece formed in accordance with the present invention and used to interconnect adjacent lighting fixtures of the present invention.

FIG. 11 is a perspective view of an exemplary arrangement of lighting fixtures formed in accordance with the present invention.

FIG. 12 is a perspective view of another exemplary arrangement of lighting fixtures formed in accordance with the present invention.

FIG. 13 is a front perspective view of the lighting fixture of the present invention, shown without a diffuser or lens mounted on the front side thereof.

FIG. 14 is a top perspective view of the lighting fixture of the present invention, shown without a diffuser or lens mounted on the front side thereof.

FIG. 15 is a rear perspective view of the lighting fixture of the present invention.

3

FIG. 16 is a bottom, rear perspective view of the lighting fixture of the present invention.

FIG. 17 is a top, rear perspective view of the lighting fixture of the present invention.

FIG. 18 is another rear perspective view of the lighting fixture of the present invention.

FIG. 19 is a side perspective view of the lighting fixture of the present invention, shown without a diffuser or lens mounted on the front side thereof.

FIG. 20 is a front perspective view of the lighting fixture of the present invention, shown without a diffuser or lens mounted on the front side thereof.

FIG. 21 is a front, top perspective view of a pair of lighting fixtures formed in accordance with the present invention joined together with an interlock piece, and illustrating a diffuser or lens mounted on the front side of each of the lighting fixtures.

FIG. 22 is a top, rear perspective view of the pair of lighting fixtures of the present invention joined together with an interlock piece, each lighting fixture having a diffuser or lens mounted on the front side thereof.

FIG. 23 is a front perspective view of the pair of lighting fixtures of the present invention joined together with an interlock piece, and showing a diffuser or lens mounted on the front side of each lighting fixture and held in place thereon.

FIG. 24 is a rear perspective view of the pair of lighting fixtures of the present invention joined together with an interlock piece, and shown with a diffuser or lens mounted on the front side of each lighting fixture.

FIG. 25 is a top perspective view of the pair of lighting fixtures of the present invention joined together with an interlock piece, and shown with a diffuser or lens mounted on the front side of each lighting fixture.

FIG. 26 is a side perspective view of the pair of lighting fixtures of the present invention joined together with an interlock piece, and shown with a diffuser or lens mounted on the front side of each lighting fixture.

FIG. 27 is a transverse cross-sectional view illustrating a pair of lighting fixtures formed in accordance with the present invention joined together with an interlock piece.

FIG. 28 is an exploded front isometric view of another form of the lighting fixture of the present invention.

FIG. 29 is a more detailed, exploded front isometric view of the lighting fixture of the present invention shown in FIG. 28.

FIG. 30 is an exploded rear isometric view of a slide assembly of the lighting fixture shown in FIGS. 28 and 29.

FIG. 31 is a rear isometric view of the slide assembly of the lighting fixture shown in FIG. 30 in an assembled form.

FIG. 32 is an exploded front isometric view of a reflector assembly of the lighting fixture of the present invention shown in FIGS. 28 and 29.

FIG. 33 is a front perspective view of the reflector assembly of the lighting fixture of the present invention shown in FIG. 32.

FIG. 34 is a top plan view of a spring clip attachment of the present invention used for holding a diffuser or lens in place on the fixture.

FIG. 35 is a perspective view of the spring clip attachment of the present invention shown in FIG. 34.

FIG. 36 is another exploded front isometric view of a reflector assembly of the lighting fixture of the present invention shown in FIG. 32.

FIG. 37 is a front perspective view of the reflector assembly of the lighting fixture of the present invention shown in FIG. 36.

4

FIG. 38 is an exploded isometric view of an interlock assembly for use with the lighting fixture of the present invention shown in FIGS. 28 and 29.

DETAILED DESCRIPTION OF THE PREFERRED EMBODIMENTS

Referring initially to FIGS. 1 and 2 of the drawings (reference may also be had to FIGS. 13-20), it will be seen that an interlocking lighting fixture 2 constructed in accordance with the present invention includes a housing 4 having a polygonally-shaped main body 6 that includes a plurality of interconnected, generally planar side walls 8 situated about the periphery thereof. The main body 6 of the housing 4 is preferably hexagonal in shape in transverse cross-section, but it is envisioned to be within the scope of the present invention to form the housing with any number of side walls 8, such as three or more, as long as the transverse width of each side wall is sufficient to accommodate its interconnection to a corresponding side wall of a similarly shaped lighting fixture 2.

The main body 6 of the housing defines an interior space or cavity 10 for receiving one or more light emitting devices 12 and electronic circuitry for controlling the illumination of the light emitting devices, as well as a cooling fan 13. The main body 6 of the housing 4 has an open front side 14 and an opposite open rear side 16.

The housing 4 of the lighting fixture 2 further includes a rear plate assembly 18, which is mounted on the open rear side 16 of the main body of the housing, and a front plate assembly 20, which is mounted on the open front side 14 of the main body 6 of the housing. As can be seen from FIG. 1, a hanger assembly 22 is mounted to the main body 6 of the housing and is provided for mounting the lighting fixture 2 from an overhead supporting structure so that it is in a suspended state, or to a supporting wall or floor.

An exploded view of several of the main components of the lighting fixture 2 of the present invention is shown in FIG. 2. Here, it is more clearly seen that the housing 4 includes the main body 6, defining an interior space or cavity 10 within which is received an electronics module 24, which contains the power supply circuit for driving the light emitting devices 12, and an assembly 26 containing the light emitting devices 12. Also, it may be seen from FIG. 2 how the rear plate assembly 18 is mounted on the open rear side 16 of the main body of the housing, and how the front plate assembly 20 is mounted on the open front side 14 of the main body of the housing, the light emitting devices 12 on their assembly being situated in proximity to the front plate assembly 20. Also, in FIG. 2, it will be seen how the hanger assembly 22 may be mounted to two diametrically opposite side walls 8 of the main body of the housing.

The polygonally-shaped main body 6 of the housing, which is shown in FIG. 2 as hexagonal in transverse cross-section in its preferred form, includes a plurality of side walls 8, as mentioned previously. Each side wall 8 has a recessed portion 28 formed in the outer surface thereof to define a channel or slot 30 that is preferably dovetailed in transverse cross-sectional shape. With this dovetailed shape of the channel or slot 30 thus being formed, two laterally opposite portions 32 of the side wall facing each other overhang the lateral edges of the recessed portion 28 and the channel or slot 30 defined thereby. The dovetailed channels or slots 30 formed in the side walls are provided for mounting the hanger assembly 22 to the main body 6 of the housing and, as will be seen, for interconnecting one lighting fixture 2 to another, similarly structured lighting fixture.

5

Referring now to FIG. 3 of the drawings, a preferred form of the hanger assembly 22 is shown. The hanger assembly 22 preferably includes a hanger 34 formed as a U-shaped member, with a central cross leg 36 and two opposite side legs 38 extending downwardly and perpendicularly from the ends of the central cross leg. A hanger block 40 is mounted on the free end of each side leg 38 of the hanger. As can be seen from FIG. 3, each hanger block 40 has an outer segment 42 and an inner segment 44 situated axially opposite the outer segment, where the inner segment 44 has a greater width than that of the outer segment 42. The widths of the inner and outer segments 44, 42 are chosen so that the hanger block 40 may be captively received by, and reciprocatingly slideable within, a corresponding dovetailed-shaped channel or slot 30 formed in each of two side walls 8 of the main body of the housing situated diametrically opposite one another on the housing main body 6.

The hanger assembly 22 also includes a pair of hanger wing nuts or knobs 46, each wing nut or knob being affixed to a respective free end of a side leg 38 of the U-shaped hanger 34. A bolt 48 passes through an axial bore formed through the center of the wing nut or knob 46. This bolt 48 is threaded over a portion thereof, and is also received by a threaded bore formed through the thickness of the hanger block. By the user turning each hanger wing nut or knob 46, the free end of the bolt 48 pulls the inner segment 44 of the hanger block 40 tightly in engagement with the inner surfaces of the opposite portions 32 of the side wall which overhang the recessed portion 28 of the dovetailed channel or slot 30 so as to secure the hanger assembly 22 on the main body 6 of the housing of the lighting fixture 2 in a desired position along the length of the channel or slot 30 of the side walls on which the hanger assembly is mounted. Furthermore, as can be seen from FIG. 3, the U-shaped hanger 34 may be positioned at any desired angle with respect to the longitudinal axis of the main body 6 of the housing so that the lighting fixture 2 may be directed to illuminate an object at any desired angle.

Referring now to FIG. 4 of the drawings, the rear plate assembly 18 is shown in greater detail. It can be seen from FIG. 4 that the rear plate assembly 18 includes a rear plate 50 that is generally planar in shape and has an outer periphery which conforms to the overall polygonal shape of the main body 6 of the housing 4. The rear plate assembly 18 is affixed to the open rear side 16 of the main body using fasteners, such as machine screws, which pass through spaced apart openings 52 formed through the thickness of the rear plate 50 of the assembly at peripheral locations on the plate, and are received by threaded openings formed axially in the rear edge of the main body 6 of the housing 4 at the open rear side 16 thereof.

The rear plate assembly 18 includes a generally planar plate 50, as mentioned previously, a fan cover or grill 54 mounted on the plate 50 and in communication with an opening formed through the thickness of the rear plate, the fan being preferably mounted in proximity to the fan cover or grill 54, a power connector 56, a control signal connector 58 and a control panel 60.

More specifically, a power connector 56 is mounted to the plate 50 of the rear plate assembly 18. The power connector 56 is preferably a male connector which mates with a corresponding female connector that is mounted on the end of a power electrical cord. The power connector 56 may be used to provide power to the electronic circuitry and light emitting devices 12 situated within the housing of the lighting fixture.

The control signal connector 58 is also mounted to the plate 50 of the rear plate assembly 18. The control signal connector 58 is preferably a male connector to which a corresponding female connector on the end of a control signal electrical cord

6

is mateable to provide control signals to the electronic circuitry so that the illumination of the light emitting devices 12 within the lighting fixture 2 may be controlled remotely (i.e., externally of the lighting fixture) from a central lighting control unit.

As shown in FIG. 4, there is also preferably a control panel 60 that is mounted on the plate 50 of the rear plate assembly 18. This control panel 60 may include an LCD (liquid crystal display) 62 or other type of display, and a plurality of push button switches 64, so that the user of the lighting fixture 2 may input control signals directly from the control panel 60 to set up or program the lighting fixture to illuminate one or more of the light emitting devices 12.

The rear plate 50 is also formed with a plurality of dovetailed-shaped open slots 66 formed in the periphery of the rear plate. These dovetailed-shaped open slots 66 are spaced apart from each other along the periphery of the rear plate so that, when the rear plate assembly 18 is mounted on the open rear side 16 of the main body of the housing, they will be in alignment with the dovetailed channels 30 formed in the side walls 8 of the main body of the housing.

FIG. 5 shows the front plate assembly 20 of the lighting fixture in greater detail. Like the rear plate assembly 18, the front plate assembly 20 includes a front plate 68 that is generally planar in shape and at its periphery it is polygonal to conform to the overall shape of the main body 6 of the housing 4. However, the front plate 68 does not include the dovetailed-shaped open slots as are formed in the rear plate 50 so that it has portions 69 situated in alignment with the channels or slots 30 formed in the side walls 8 of the main body 6 of the housing. These portions 69 (which may but preferably do not extend beyond the polygonal periphery of the front plate 68) act as stops for interlock pieces 92 received by the channels or slots 30 when two or more fixtures 2 are joined together, as will be described in greater detail. Also, like the rear plate assembly 18, the plate 68 of the front plate assembly 20 includes a series of spaced apart holes 70 formed through the thickness thereof near its periphery which are aligned with corresponding threaded holes formed axially in the front edge of the main body 6 of the housing at the open front side 14 thereof and which receive fasteners, such as machine screws, therethrough that are also received by the corresponding threaded holes of the main body to secure the front plate assembly 20 to the main body of the housing. As also shown in FIG. 5, the front plate 68 has a large central opening 72 formed through its thickness to allow light from the light emitting devices 12 to pass therethrough.

As can be more clearly seen in FIG. 5, removeably mounted on the exposed front side (or, alternatively, unexposed rear side) of the plate 68 of the front plate assembly 20 and in alignment with the central opening 72 in the plate is a diffuser or lens 74. The diffuser or lens 74, when mounted on the front side of the front plate 68, is held in place on the surface of the front plate 68 by a pair of elongated L-shaped brackets 76 mounted on and extending outwardly from the front (or rear) surface of the front plate and on diametrically opposite sides thereof. There is further provided a smaller, L-shaped center bracket 78 situated on the surface of the front plate 68 near the periphery thereof and between the diametrically opposed, elongated L-shaped brackets 76. The diffuser or lens 74 is dimensioned in size to be received between the diametrically opposed, elongated L-shaped brackets 76 on opposite lateral sides of the diffuser or lens and to be received by the smaller, L-shaped center bracket 78 on another side of the diffuser or lens. Also provided is a spring pin 80 which is biased by a spring (not shown) so that the free end or tip thereof extends outwardly from the same surface of the front

plate **68** on which the L-shaped brackets **76**, **78** are mounted and is situated diametrically opposite the L-shaped center bracket **78**. A suitable alternative to the spring pin **80** is the resilient, raised clip **82** included on the fixtures **2** shown in FIGS. **11** and **12**, which clip **82** would function in the same manner as the spring pin **80** shown in FIG. **5**.

When mounting the diffuser or lens **74** to the front plate **68**, the diffuser or lens pushes the spring pin **80** into the front plate so that its tip does not protrude outwardly from the surface of the front plate. The diffuser or lens **74** is then inserted between the elongated L-shaped brackets **76** until an edge of the diffuser or lens rests in the center L-shaped bracket **78**, and the opposite edge of the diffuser or lens passes radially inwardly of the spring pin **80**. Then, the spring pin **80** is released such that its tip protrudes outwardly from the surface of the front plate **68** on which the diffuser or lens **74** is mounted, thereby captively holding the diffuser or lens in place on the front plate. The diffuser or lens **74** may be easily removed from the front plate **68** by the user pushing in the tip of the spring pin **80** so that it is flush with the surface of the front plate and withdrawing the lens from between the elongated, L-shaped brackets **76** and over the depressed spring pin **80**.

A preferred form of the assembly **26** containing the light emitting devices **12** is shown in FIG. **6**. The light emitting devices **12** may be incandescent or halogen bulbs, or may take on other forms of lighting, but are preferably light emitting diodes (LEDs). The LEDs are preferably arranged as clusters **84** containing one or more LEDs (five clusters of seven LEDs are shown in FIG. **6**). Each cluster **84** may contain LEDs of the same wavelength or of different wavelengths, to emit light of the same or different colors, for example, white, red, blue or green, when energized. The light emitting devices **12** are mounted on a printed circuit board **86** which, in turn, is mounted on or thermally coupled to a finned heatsink **88** to dissipate the heat generated by the light emitting devices **12**. The assembly **26** which contains the light emitting devices is positioned within the interior space or cavity **10** of the main body **6** of the housing in proximity to the front plate assembly **20** and in alignment with the central opening **72** formed in the front plate **68** so that the light emitting devices **12** or LED clusters **84** mounted on the printed circuit board **86** face the diffuser or lens **74** of the front plate assembly.

FIG. **7** illustrates the electronics module **24**. The electronics module **24** includes a power supply **89** for providing power to energize the light emitting devices **12** on the prior assembly **26** described. The power supply **89** is preferably connected to the power connector **56** mounted on the rear plate **50** of the fixture, and receives power over an external power cord connected thereto. The electronics module **24** is mounted on a driver printed circuit board **90**, and further includes a mounting bracket **91** situated thereon for mounting the electronics module **24** within the interior space or cavity **10** of the main body of the housing, as described previously and shown in FIG. **2** of the drawings.

As also described previously, adjacent lighting fixtures **2** of the present invention may be interconnected to each other at side walls **8** of the main body **6** of their housings which face each other so that a modular arrangement of lighting fixtures **2** may be formed in a plurality of configurations. One way of joining adjacent lighting fixtures together is by using an interlock piece **92**, such as shown in FIGS. **8-10** of the drawings. Reference may also be had to FIGS. **21-27** for additional views of lighting fixtures **2** that are joined together, as will be described. Note that certain features of the fixtures **2** have not been included in these drawings to facilitate an understanding of how the fixtures are joined together.

More specifically, the interlock piece **92** has a generally elongated member **94** formed from a pair of laterally conjoined tubular members **96**, each tubular member **96** having a bumper or rubberized cushion **98** situated on one axially end thereof. A rotatable fastener or knob **100** is situated at an opposite axial end of the elongated member **94**. The fastener or knob **100** is connected to the elongated member **94** of the interlock piece **92** with a friction bushing **102** interposed between the axial end face of the elongated member and the fastener, with the fastener **100** being rotatable on the axial end of the elongated member **94**.

As shown in FIGS. **9** and **10**, the fastener or knob **100** has a main body **104** which is generally elliptical in transverse cross-section over its axially outer portion to allow it to be more easily grasped and turned by a user. The fastener or knob **100** of the interlock piece **92** also includes on its main body **104** a pair of flanges **106** situated near its axially inner edge that is adjacent to the axial end of the elongated member **94** on which the fastener is connected. These flanges **106** protrude outwardly from the main body **104** of the fastener or knob **100** on diametrically opposite sides thereof. Each flange **106** includes an arcuate peripheral outer edge **108**, and a raised lip **110** situated at this edge **108**. As will be described, by turning the fastener or knob **100**, these protruding flanges **106** will prevent the interlock piece **92** from being removed, or permit the interlock piece to be removed, from between two facing side walls **8** of adjacent lighting fixtures **2**, depending upon the rotational position of the fastener or knob **100**.

More specifically, and as shown in FIGS. **9** and **10** of the drawings, each interlock piece **92** (and there may be several interlock pieces used to join one lighting fixture to one or more adjacent lighting fixtures) includes a first pair or set of mutually diverging fins **112**, **114** situated on a lateral side of the elongated member **94** of the interlock piece **92** and along the axial length of one tubular member **96**, and a second pair or set of mutually diverging fins **112**, **114** situated on an opposite lateral side of the elongated member **94** of the interlock piece **92** and along the axial length of the other tubular member **96**. Thus, each of the first and second sets of fins includes a first angled fin **112** and a second angled fin **114**, each fin **112**, **114** preferably extending radially outwardly from the tubular member **96** on which it is formed.

In order to join two lighting fixtures **2** together, the fixtures are placed such that the planar side wall **8** of the main body of the housing of one fixture **2** is situated in close proximity to a planar side wall **8** of the main body of the housing of another fixture, with the side walls **8** of the fixtures **2** facing one another and the housings **4** situated in parallel. Then, the interlock piece **92** is fitted between the two facing side walls **8** of adjoining fixture housings **4** by sliding the elongated member **94** into the channels or slots **30** of the facing side walls **8**.

Even more specifically, the first angled fins **112** of the first and second set of fins is received in the dovetailed channel or slot **30** of the side wall **8** of one lighting fixture **2**, and the second angled fins **114** of the first and second set of fins is received in the dovetailed channel or slot **30** of the side wall **8** of the second lighting fixture **2**. The interlock piece **92** is oriented such that the bumpers or cushions **98** situated at one axial end of the elongated member **94** of the interlock piece are directed toward the front plates **68** of the lighting fixtures and so that the fastener **100** is situated near the rear plates **50** of the lighting fixtures **2** to be joined. The interlock piece **92** is received by the dovetailed channels or slots **30** of the lighting fixtures from the open end of the channels or slots situated at the rear plate assembly **18** of each fixture, and is forced inwardly into the channels toward the front plates **68** of

the adjacent lighting fixtures. The interlock piece **92** is slid through the dovetailed-shaped open slots **66** of the rear plate **50** and into the channels **30** of the side walls **8** of the lighting fixtures which face one another. More specifically, the first angled fins **112** of the first and second sets of fins are received under the overhanging portions **32** of a side wall **8** defining a respective dovetailed channel or slot **30** of one lighting fixture, and the second angled fins **114** of the first and second sets of fins are received under the overhanging portions **32** of the side wall **8** defining the respective channel or slot **30** of the other lighting fixture.

Because the front plate **68** of each lighting fixture **2** includes extended portions **69** which are in alignment with the channels or slots **30** of the main body **6** of the housing, a respective bumper or cushion **98** of the interlock piece **92** will engage the rear surface of the front plate **68** of each of the adjoining lighting fixtures **2** at these extended portions as the interlock piece is slid into the channels of the facing side walls of the housings. The overall axial length of the interlock piece **92**, and in particular the elongated member **94** thereof, is chosen so that the fastener **100** of the interlock piece extends slightly beyond the open rear side **16** of the main body of the housing of each lighting fixture **2** now joined together by the interlock piece.

Returning again to FIGS. **2** and **4** of the drawings, it can be seen that the rear plate assembly **18** also includes U-shaped catches **116** extending outwardly from the rear surface of the rear plate **50**. These catches **116** are spaced apart from each other, and each catch is situated in alignment with the recessed portion **28** of the dovetailed channel **30** of a respective side wall **8** of the main body of the housing when the rear plate assembly **18** is mounted on the main body of the housing. Each U-shaped catch **116** defines with the rear surface of the rear plate **50** a slot **118** for receiving a protruding flange **106** of the fastener **100** of the interlock piece, depending upon the orientation of the fastener.

When a user attaches two fixtures **2** together, he inserts the interlock piece **92** into the channels or slots **30** of two facing side walls **8** of the fixtures, and forces the interlock piece with slight pressure against the rear surface of the front plate **68** of the adjoining lighting fixtures **2** at the extended portions **69** such that the bumpers or rubberized cushions **98** are slightly compressed. Then, the fastener **100** of the interlock piece **92** is turned to cause the protruding flanges **106** and raised lips **110** on the flanges of the fastener to be at least partially received by the slot **118** of the U-shaped catches **116** situated in alignment therewith. Since the flanges **106** extend outwardly from opposite sides of the fastener **100**, they will engage the U-shaped catches **116** and be received by their respective slots **118** of the two adjacent lighting fixtures **2**. The slight compression of the bumpers **98** against the front plates **68** of the two lighting fixtures will bias and exert some pressure on the flanges **106** against the U-shaped catches **116** to minimize any rotation of the fastener **100** and to prevent the flanges from dislocating from the slots **118** of the U-shaped catches **116** of the adjacent lighting fixtures **2**, thereby helping to secure the lighting fixtures together.

Of course, when joining two lighting fixtures together, the interlock piece **92** is used between two facing side walls **8** that are available for interconnection and which do not have the hanger assembly **22** mounted thereto.

As mentioned previously, the lighting fixture **2** of the present invention may be joined to other similarly shaped lighting fixtures to form a modular arrangement of lighting fixtures in a plurality of configurations. Some of these configurations are shown in FIGS. **11** and **12**.

For example, and as shown in FIG. **11**, a circular arrangement of six lighting fixtures **2** may be formed by joining adjacent side walls **8** of the lighting fixtures with interlock pieces **92**. A single hanger assembly **22**, having an extended central cross leg **36** to bridge two interconnected lighting fixtures **2** of the modular arrangement, may be affixed to the opposite, non-facing sides **8** of a pair of interconnected lighting fixtures **2** of the arrangement in order to suspend the arrangement from a ceiling or other support member, or multiple hanger assemblies may be used. In the example of the arrangement shown in FIG. **11**, each lighting fixture **2** preferably has a hexagonally-shaped housing **4**.

Another arrangement of lighting fixtures **2** formed in accordance with the present invention is illustrated by FIG. **12**. Here, again, six lighting fixtures **2**, each having a hexagonally-shaped housing **4**, are joined in close proximity to one another. Again, interlock pieces **92** are used to join adjacent side walls **8** of the lighting fixtures together.

In each of the modular arrangements shown in FIGS. **11** and **12**, it can be seen that the lighting fixtures **2** have their light directed in the same direction to illuminate together an object, without requiring each lighting fixture to be individually adjusted as must be done with conventional, non-interlocking lighting fixtures. It should also be realized that the arrangements of lighting fixtures shown in FIGS. **11** and **12** are provided for exemplary purposes only, and such lighting fixtures may be arranged in a plurality of configurations to best suit the needs of the user.

Another form of a lighting fixture, and certain components thereof, constructed in accordance with the present invention, is shown in FIGS. **28-38**. As shown in FIG. **28**, the lighting fixture includes a main body **6** substantially having the features and structure described previously. Through the rear axial open end **16** of the main body **6** is received an internal slide assembly **150**. On the front axial open end **14** of the main body **6** is received a reflector assembly **152** and diffuser holding fixture, also referred to herein as a front plate assembly **20**.

As also can be seen from FIG. **28**, a back plate assembly **18** is mounted on the rear open axial end **16** of the main body **6** of the fixture. The back plate assembly **18** is mounted on bent flanges **154** on the rear side of the internal slide assembly **150**, which assembly is received within the internal cavity **10** of the main body **6**.

FIG. **29** is another view of the lighting fixture shown in FIG. **28**. Although not shown in FIG. **29**, a yoke hanger assembly **22**, such as described previously with respect to the other embodiments of the lighting fixture, is adjustably mounted on the outer surface or side walls **8** of the main body **6**. Furthermore, the reflector assembly **152** is received within the cavity **10** of the main body **6** of the lighting fixture through the open front axial end **14** thereof, and the front plate assembly **20** is mounted on the main body **6** on the open front end **14** thereof.

FIGS. **30** and **31** show in detail the structure of the internal slide assembly **150**. Basically, the slide assembly includes a three-sided frame **156**. A lower plate **158** with standoffs **160** is mounted on the bottom of the frame **156**. The lower plate **158** supports a power supply **89** for the light emitting diodes (LEDs) **12**, which preferably provides sixty-five (65) watts of power. The power supply **89** has a supporting flange **162** on the lower surface of its housing which is mounted to the standoffs **160** by screws **164**.

Also mounted to the frame **156** of the internal slide assembly **150** is a finned heat sink **88**. The heat sink **88** is mounted to a partially open front side **166** of the three-sided frame **156**.

11

The optics assembly **168**, which includes a plurality of LEDs **12**, is mounted on the partially open front side **166** of the three-sided frame **156**, and is thermally coupled to the heat sink **88** so that the heat sink may dissipate the heat generated by the plurality of LEDs **12**.

The internal slide assembly **150** is advantageous in that the entire unit slides into and is affixed within the internal cavity **10** of the main body **6** of the lighting fixture, and may be removed as a single unit.

FIGS. **32-37** illustrate in detail the reflector assembly **152** and the front plate assembly **20** of the lighting fixture shown in FIGS. **28** and **29**. As mentioned previously, the reflector assembly **152** is received through the open front axial end **14** of the main body **6**, and is affixed to the front end **14** of the main body **6** by the front plate assembly **20**. The reflector assembly **152** includes a reflector **170**, and a reflector retaining ring **172**. The reflector retaining ring **172** includes holes **174** formed therein which are aligned with openings or screw receivers **176** formed on the front face **14** of the main body **6** and with openings **178** formed in the front plate assembly **20**, so that machine screws **180** may pass through the openings **178**, **174** in the front plate assembly **20** and the reflector retaining ring **172** to hold the front plate assembly **20** and the reflector assembly **152** in place on the front face of the main body **6** of the lighting fixture. As can be seen in FIGS. **32**, **33**, **36** and **37** of the drawings, the reflector **170** has a truncated conical shape and is used to help direct light emitted by the plurality of LEDs **12** in an axial direction from the front of the lighting fixture.

It should also be noted from FIGS. **32** and **33** that a spring clip attachment **200** is included and mounted to the front plate assembly **20**. The spring clip attachment **200**, which includes a resilient, partial coiled spring **202** having a hooked end **204** mounted on a bracket **206**, is used to retain a diffuser lens on the front plate assembly **20**. The spring clip attachment **200** is also shown in greater detail in FIGS. **34** and **35**.

FIGS. **36** and **37** illustrate another form of a diffuser or lens retaining spring clip attachment **201** which is mounted on the front plate assembly **20**. An elongated member **203** is attached to and between two generally L-shaped pieces **205** and extends outwardly therefrom. The L-shaped pieces **205** are, in turn, attached to two resilient, oblong leaf springs **207**, whose ends are affixed to the rear surface of the front plate **68** of the front plate assembly. More specifically, in this embodiment, the front plate **68** is formed in two first and second sections, **68A** and **68B**, and the diffuser or lens retaining spring clip attachment **201** is mounted on the first section **68A**. The elongated member **203** is received by and passes through an opening **209** formed through the thickness of the front plate **68** (more specifically, the first section **68A** thereof), the opening **209** being shaped to conform to the cross-sectional shape of the elongated member **203**. In much the same way as the spring pin **80**, described previously, functions, the elongated member **203** may be pushed through the opening **209** and into the front plate **68** against the bias of the leaf springs **207** by the user as he is mounting the diffuser or lens **74** on the lighting fixture so that a diffuser or lens **74** may be received by the front plate assembly **20**, and then released so as to protrude outwardly from the front face of the front plate **68**, biased by the leaf springs **207**, so as to retain the diffuser or lens **74** in place on the front plate assembly **20**.

FIG. **38** illustrates another form of the interlock assembly **92** used in the lighting fixture of the present invention. The features and structure of the interlock assembly **92** shown in FIG. **34** are substantially the same as those shown in FIGS. **8-10** of the drawings. However, a helical spring **182** has been added, surrounding a bushing **102** on which the interlock

12

locking knob **100** is mounted. The helical spring **182** is situated between an end face **186** of the interlock extrusion **92** and the bottom surface of the locking knob **100**.

The purpose of the spring **182** is to exert an axially outward force on the locking knob **100** so as to ensure that the raised lips **110** on the protruding flanges **106** (see FIG. **9**) engage the slots **118** of the U-shaped catches **116** (see FIG. **4**).

To summarize some of the features of the present invention, a lighting fixture **2**, constructed in accordance with the present invention, includes a housing **4**. The housing **4** has an overall polygonal shape and includes a plurality of generally planar side walls **8**. The housing further **4** defines an interior space. Each side wall **8** of the polygonally-shaped housing includes cooperating structure which allows one of the side walls **8** of the housing **4** of the lighting fixture **2** to be interlocked with a generally planar side wall **8** of the housing **4** of another similarly-structured lighting fixture **2**.

The lighting fixture **2** also includes an interlock piece **92**, the interlock piece **92** being attachable to the cooperating structure of a side wall **8** of the housing **4** of the lighting fixture **2** and to cooperating structure of a side wall **8** of the housing **4** of another similarly-structured lighting fixture **2** to join the lighting fixture **2** and a similarly-structured lighting fixture **2** together to form a modular arrangement of lighting fixtures.

Stated another way, the lighting fixture **2** basically includes the housing **4** and the interlock piece **92**. The housing **4** includes a main body **6** having an overall polygonal shape and including a plurality of generally planar side walls **8**, the main body **6** defining an interior space. Each side wall **8** of the polygonally-shaped main body **6** of the housing **4** has an outer surface and an elongated channel **30** formed in the outer surface. The interlock piece **92** has an elongated member **94** which is at least partially receivable by the elongated channel **30** formed in each side wall **8** of the main body **6** of the housing **4** to interconnect the lighting fixture **2** with another, similarly-structured lighting fixture **2**.

Preferably, the elongated channel **30** formed in the outer surface of each side wall **8** of the main body **6** of the housing **4** has a dovetail transverse cross-sectional shape, each side wall **8** of the main body **6** having a recessed portion **28** formed in the outer surface thereof and two laterally opposite portions **32** which face each other and partly overhang the recessed portion **28**. Thus, the recessed portion **28** of each side wall **8** and the two laterally opposite portions **32** of the each side wall **8** at least partially define the elongated channel **30** formed in the outer surface of each side wall **8** of the main body **6**.

There is at least one light emitting device **12** disposed within the interior space defined by the main body **6** of the housing **4**. Furthermore, the lighting fixture **2** includes electronic circuitry **24** electrically coupled to the at least one light emitting device **12** to control the illumination thereof.

Even more preferably, the lighting fixture **2** of the present invention includes a slide frame assembly **150**, the slide frame assembly **150** being removably mounted within the interior space defined by the main body **6** of the housing **4**. The slide frame assembly **150** has mounted thereon the at least one light emitting device **12** and the electronic circuitry **24**.

The main body **6** of the housing **4** of the lighting fixture **2** preferably includes a front side **14** and a rear side **16** situated axially opposite the front side **14**, and the housing **4** preferably includes a rear plate assembly **18** mounted to the main body **6** at the rear side **16** thereof, and a front plate assembly **20** mounted to the main body **6** at the front side **14** thereof, the at least one light emitting device **12** being situated in the interior space of the main body **6** to emit light that is directed towards the front plate assembly **20**.

13

The rear plate assembly **18** includes a rear plate **50**, the rear plate **50** being generally planar in shape and having an outer periphery which conforms to the overall polygonal shape of the main body **6** of the housing **4**. The rear plate assembly **18** further includes a power connector **56** and a control signal connector **58**, each of the power connector **56** and the control signal connector **58** being mounted on the rear plate **50**.

Preferably, the rear plate assembly **18** further includes a control panel **60**, the control panel **60** being mounted on the rear plate **50** and including a display **62** and a plurality of switches **64** so that a user of the lighting fixture **2** may input control commands to the lighting fixture to control the illumination of the at least one light emitting device **12**. The rear plate **50** may also be formed with a plurality of open slots **66** situated about the periphery thereof, the open slots **66** being spaced apart from each other, each open slot **66** being aligned with a corresponding channel **30** formed in a side wall **8** of the main body **6** of the housing **4**.

The front plate assembly **20** preferably includes a front plate **68**, the front plate **68** being generally planar in shape. Also, each elongated channel **30** formed in the side walls **8** of the main body **6** of the housing **2** includes a first axial end situated near the front side **14** of the main body **6** of the housing **2** and a second axial end situated opposite the first axial end and near the rear side **16** of the main body **6** of the housing **4**. Furthermore, the front plate **68** preferably includes portions **69** thereof which extend outwardly to cover the first axial end of each elongated channel **30** formed in the side walls **8** of the main body **6** of the housing **4**, the portions **69** acting as stops which are engagable by the interlock piece **92**.

In another preferred form of the lighting fixture **2** of the present invention, the front plate **68** includes a front surface, and the front plate assembly **20** further includes a pair of L-shaped brackets **76**. The L-shaped brackets **76** are situated on the front surface of the front plate **68** and extend outwardly therefrom, the L-shaped brackets **76** being spaced apart from each other to receive therebetween one of a lens and a diffuser **74**.

Also, the front plate assembly **20** further preferably includes a mechanism for selectively holding the one of the lens and the diffuser **74** in place between the pair of L-shaped brackets **76** on the front surface of the front plate **68**. In one form, the mechanism includes a retractable spring member **80**, **203** mounted on the front plate **68**, the spring member **80**, **203** being selectively positionable in at least a first position in which the spring member **80**, **203** extends outwardly from the front surface of the front plate **68** a first distance, and a second position in which the spring member **80**, **203** at least one of 1) does not extend outwardly from the front surface of the front plate **68**, and 2) extends outwardly from the front surface of the front plate **68** a second distance, the first distance being greater than the second distance. In another form, the mechanism includes a resilient, partially coiled spring **202** having a hooked end **204**, the hooked end **204** of the spring **202** being selectively positionable in at least a first position to retain the one of the lens and the diffuser **74** in place on the front surface of the front plate **68**, and a second position to allow the one of the lens and the diffuser **74** to be removed from a position on the front surface of the front plate **68**.

The lighting fixture **2** also preferably includes a hanger assembly **22**, the hanger assembly **22** being mountable to the main body **6** of the housing **4**. The hanger assembly **22** includes at least one hanger block **40**, the at least one hanger block **40** being receivable in the elongated channel **30** formed in one of the side walls **8** of the main body **6** and being selectively positionable along the axial length of the elongated channel **30**.

14

In a more preferred form, the hanger assembly **22** includes a hanger piece **34** formed as a generally U-shaped member, the hanger piece **34** including a central cross leg **36** having opposite axial ends, and first and second opposite side legs **38** extending at an angle from the opposite axial ends of the central cross leg **36**. Each of the first and second side legs **38** has a free end. The hanger assembly **22** further includes first and second hanger blocks **40**, the first hanger block **40** being mounted to the free end of the first side leg **38**, and the second hanger block **40** being mounted to the free end of the second side leg **38**. The first and second hanger blocks **40** are receivable by elongated channels **30** formed in respective side walls **8** of the main body **6** of the housing **2** and are selectively positionable along the axial lengths of the elongated channels **30**.

The interlock piece **92** of the lighting fixture **2**, in a preferred form, includes a generally elongated member **94** having a pair of laterally conjoined tubular members **96**, the elongated member **94** having a first axial end and a second axial end disposed opposite the first axial end. Each tubular member **96** has a first axial end situated in proximity to the first axial end of the elongated member **94**, and a second axial end situated opposite the first axial end of the tubular member **96**. The interlock piece **92** further includes a resilient cushioning piece **98** situated at the first axial end of each tubular member **96**, and a rotatable fastener **100** mounted on the second axial end of the elongated member **94**.

Furthermore, each tubular member **96** includes at least one projection extending radially outwardly therefrom along at least a portion of the longitudinal length thereof, the radially extending projection of each tubular member **96** being receivable by the elongated channel **30** formed in a respective side wall **8** of the main body **6** of the housing **4**. Preferably, the at least one projection includes first and second angled fins **112**, **114** spaced apart from each other and extending radially outwardly from the outer surface of each tubular member **96**, the first and second angled fins **112**, **114** of one of the tubular members **96** being receivable by the elongated channel **30** formed in a respective side wall **8** of the main body **6** of the housing **4**.

The rotatable fastener **100** of the interlock piece **92** preferably includes a main body **104** and a pair of flanges **106** extending outwardly from the main body **104** of the fastener **100**. As mentioned previously, the main body **6** of the housing **4** of the lighting fixture **2** includes a front side **14** and a rear side **16** situated axially opposite the front side **14**. Also, each elongated channel **30** formed in the side walls **8** of the main body **6** of the housing **4** includes a first axial end situated near the front side **14** of the main body **6** of the housing **4** and a second axial end situated opposite the first axial end and near the rear side **16** of the main body **6** of the housing **2**. As also mentioned previously, the housing **4** further includes a rear plate assembly **18** mounted to the main body **6** of the housing **4** at the rear side **16** thereof, and a front plate assembly **20** mounted to the main body **6** of the housing **4** at the front side **14** thereof. The rear plate assembly **18** includes a rear plate **50**, the rear plate **50** being generally planar in shape, and the front plate assembly **20** includes a front plate **68**, the front plate **68** being generally planar in shape and having portions **69** thereof which extend outwardly to cover the first axial end of each elongated channel **30** formed in the side walls **8** of the main body **6** of the housing **4**. These portions **69** act as stops which are engagable by the cushioning piece **98** situated at the first axial end of one of the tubular members **96** of the interlock piece **92**. Also, the rear plate **50** of the rear plate assembly **18** has an outer surface, and the rear plate assembly **18** further

15

includes a plurality of U-shaped catches **116** extending outwardly from the outer surface of the rear plate **50**.

The catches **116** are spaced apart from each other and situated in alignment with corresponding channels **30** formed in the side walls **8** of the main body **6** of the housing **4**. Each U-shaped catch **116** at least partially defines a slot **118** for receiving one of the protruding flanges **106** of the fastener **100** of the interlock piece **92** to help hold the interlock piece **92** in place at least partially within an elongated channel **30** of a respective side wall **8** of the main body **6** of the housing **4** in which the interlock piece **92** is at least partially received.

The present invention is also directed to a modular arrangement of a plurality of lighting fixtures **2**, adjacent lighting fixtures **2** being joined together. As mentioned previously, each lighting fixture **2** of the modular arrangement basically includes a housing **4**, the housing **4** including a main body **6** having an overall polygonal shape and including a plurality of generally planar side walls **8**, the main body **6** defining an interior space. Each side wall **8** of the polygonally-shaped main body **6** of the housing **4** has an outer surface and an elongated channel **30** formed in the outer surface. The modular arrangement also includes one or more interlock pieces **92**. The interlock piece **92** has an elongated member **94** which is at least partially receivable by the elongated channel **30** formed in each side wall **8** of the main body **6** of the housing **4** to interconnect the lighting fixture **2** with another, similarly-structured lighting fixture **2** of the modular arrangement.

The fixture **2** of the present invention further includes two additional features referred to herein by the trademarks Flex-Palette™ and FlexRate™. The FlexPalette™ feature allows the user of the lighting fixture **2** to select and record in memory approximately 100 static colors. More specifically, the lighting fixture **2** of the present invention offers stand-alone operation with user-programmable features of preferably 100 user-programmable color memory locations and preferably 80 user-selectable combinations of fade and/or bump timing.

The FlexRate™ feature of the lighting fixture **2** precludes strobing caused by ambient light conditions, such as when a room or stage is illuminated by fluorescent lighting. Thus, emitter output is flicker-free and includes preferably a selection of four output frequencies for each of the four DMX (digital multiplex) modes. PWM (pulse width modulation) control of LED levels is imperceptible to video cameras and similar equipment.

The lighting fixture of the present invention is envisioned to be used in many different applications, including commercial, industrial and stage lighting, and where either LEDs are used as described herein, or other light emitting devices, such as incandescent lamps, may be substituted for the LEDs. For example, the lighting fixture may be used as traffic lights or other signal devices, as well as in horticultural applications, where the LEDs are replaced with plasma light sources.

Although illustrative embodiments of the present invention have been described herein with reference to the accompanying drawings, it is to be understood that the invention is not limited to those precise embodiments, and that various other changes and modifications may be effected therein by one skilled in the art without departing from the scope or spirit of the invention.

What is claimed is:

1. A lighting fixture, which comprises:

a housing, the housing including a main body having an overall polygonal shape and including a plurality of generally planar side walls, the main body defining an interior space, each side wall of the polygonally-shaped

16

main body of the housing having an outer surface and an elongated channel formed in the outer surface; and an interlock piece, the interlock piece having an elongated member which is at least partially receivable by the elongated channel formed in each side wall of the main body of the housing to interconnect the lighting fixture with another, similarly-structured lighting fixture; wherein the elongated channel formed in the outer surface of each side wall of the main body of the housing includes a dovetail transverse cross-sectional shape, each side wall of the main body having a recessed portion formed in the outer surface thereof and two laterally opposite portions which face each other and partly overhang the recessed portion, whereby the recessed portion of each side wall and the two laterally opposite portions of the each side wall at least partially define the elongated channel formed in the outer surface of each side wall of the main body.

2. A lighting fixture as defined by claim 1, which further comprises:

at least one light emitting device disposed within the interior space defined by the main body of the housing; and electronic circuitry electrically coupled to the at least one light emitting device to control the illumination thereof.

3. A lighting fixture as defined by claim 2, which further comprises:

a slide frame assembly, the slide frame assembly being removably mounted within the interior space defined by the main body of the housing, the slide frame assembly having mounted thereon the at least one light emitting device and the electronic circuitry.

4. A lighting fixture as defined by claim 2, wherein the main body of the housing includes a front side and a rear side situated axially opposite the front side;

and wherein the housing further includes:

a rear plate assembly mounted to the main body at the rear side thereof; and

a front plate assembly mounted to the main body at the front side thereof, the at least one light emitting device being situated in the interior space of the main body to emit light that is directed towards the front plate assembly.

5. A lighting fixture as defined by claim 4, wherein the rear plate assembly includes a rear plate, the rear plate being generally planar in shape and having an outer periphery which conforms to the overall polygonal shape of the main body of the housing.

6. A lighting fixture as defined by claim 5, wherein the rear plate assembly further includes a power connector and a control signal connector, each of the power connector and the control signal connector being mounted on the rear plate.

7. A lighting fixture as defined by claim 5, wherein the rear plate assembly further includes a control panel, the control panel being mounted on the rear plate and including a display and a plurality of switches so that a user of the lighting fixture may input control commands to the lighting fixture to control the illumination of the at least one light emitting device.

8. A lighting fixture as defined by claim 5, wherein the rear plate is formed with a plurality of open slots situated about the periphery thereof, the open slots being spaced apart from each other, each open slot being aligned with a corresponding channel formed in a side wall of the main body of the housing.

9. A lighting fixture as defined by claim 4, wherein the front plate assembly includes a front plate, the front plate being generally planar in shape.

10. A lighting fixture as defined by claim 9, wherein each elongated channel formed in the side walls of the main body

17

of the housing includes a first axial end situated near the front side of the main body of the housing and a second axial end situated opposite the first axial end and near the rear side of the main body of the housing; and wherein the front plate includes portions thereof which extend outwardly to cover the first axial end of each elongated channel formed in the side walls of the main body of the housing, the portions acting as stops which are engagable by the interlock piece.

11. A lighting fixture as defined by claim 9, wherein the front plate includes a front surface, and wherein the front plate assembly further includes a pair of L-shaped brackets, the L-shaped brackets being situated on the front surface of the front plate and extending outwardly therefrom, the L-shaped brackets being spaced apart from each other to receive therebetween one of a lens and a diffuser.

12. A lighting fixture as defined by claim 11, wherein the front plate assembly further includes a mechanism for selectively holding the one of the lens and the diffuser in place between the pair of L-shaped brackets on the front surface of the front plate.

13. A lighting fixture as defined by claim 12, wherein the mechanism includes a retractable spring member mounted on the front plate, the spring member being selectively positionable in at least a first position in which the spring member extends outwardly from the front surface of the front plate a first distance, and a second position in which the spring member at least one of 1) does not extend outwardly from the front surface of the front plate, and 2) extends outwardly from the front surface of the front plate a second distance, the first distance being greater than the second distance.

14. A lighting fixture as defined by claim 12, wherein the mechanism includes a resilient, partially coiled spring having a hooked end, the hooked end of the spring being selectively positionable in at least a first position to retain the one of the lens and the diffuser in place on the front surface of the front plate, and a second position to allow the one of the lens and the diffuser to be removed from a position on the front surface of the front plate.

15. A lighting fixture as defined by claim 1, which further comprises:

a hanger assembly, the hanger assembly being mountable to the main body of the housing, the hanger assembly including at least one hanger block, the at least one hanger block being receivable in the elongated channel formed in one of the side walls of the main body and being selectively positionable along the axial length of the elongated channel.

16. A lighting fixture as defined by claim 1, which further comprises:

a hanger assembly, the hanger assembly being mountable to the main body of the housing, the hanger assembly including a hanger piece formed as a generally U-shaped member, the hanger piece including a central cross leg having opposite axial ends, and first and second opposite side legs extending at an angle from the opposite axial ends of the central cross leg, each of the first and second side legs having a free end, the hanger assembly further including first and second hanger blocks, the first hanger block being mounted to the free end of the first side leg, and the second hanger block being mounted to the free end of the second side leg, the first and second hanger blocks being receivable by elongated channels formed in respective side walls of the main body of the housing and being selectively positionable along the axial lengths of the elongated channels.

18

17. A lighting fixture, which comprises:

a housing, the housing including a main body having an overall polygonal shape and including a plurality of generally planar side walls, the main body defining an interior space, each side wall of the polygonally-shaped main body of the housing having an outer surface and an elongated channel formed in the outer surface; and an interlock piece, the interlock piece having an elongated member which is at least partially receivable by the elongated channel formed in each side wall of the main body of the housing to interconnect the lighting fixture with another, similarly-structured lighting fixture;

wherein the interlock piece includes a generally elongated member having a pair of laterally conjoined tubular members, the elongated member having a first axial end and a second axial end disposed opposite the first axial end, each tubular member having a first axial end situated in proximity to the first axial end of the elongated member, and a second axial end situated opposite the first axial end of the tubular member, the interlock piece further including a resilient cushioning piece situated at the first axial end of each tubular member, and a rotatable fastener mounted on the second axial end of the elongated member.

18. A lighting fixture as defined by claim 17, wherein each tubular member includes at least one projection extending radially outwardly therefrom along at least a portion of the longitudinal length thereof, the radially extending projection of each tubular member being receivable by the elongated channel formed in a respective side wall of the main body of the housing.

19. A lighting fixture as defined by claim 18, wherein the at least one projection includes first and second angled fins spaced apart from each other and extending radially outwardly from each tubular member, the first and second angled fins of one of the tubular members being receivable by the elongated channel formed in a respective side wall of the main body of the housing.

20. A lighting fixtures as defined by claim 17, wherein the rotatable fastener includes a main body and a pair of flanges extending outwardly from the main body of the fastener; wherein the main body of the housing includes a front side and a rear side situated axially opposite the front side; wherein each elongated channel formed in the side walls of the main body of the housing includes a first axial end situated near the front side of the main body of the housing and a second axial end situated opposite the first axial end and near the rear side of the main body of the housing; wherein the housing further includes a rear plate assembly mounted to the main body of the housing at the rear side thereof and a front plate assembly mounted to the main body of the housing at the front side thereof; wherein the rear plate assembly includes a rear plate, the rear plate being generally planar in shape; and wherein the front plate assembly includes a front plate, the front plate being generally planar in shape and having portions thereof which extend outwardly to cover the first axial end of each elongated channel formed in the side walls of the main body of the housing, the portions acting as stops which are engagable by the cushioning piece situated at the first axial end of one of the tubular members of the interlock piece, the rear plate of the rear plate assembly having an outer surface, the rear plate assembly further including a plurality of U-shaped catches extending outwardly from the outer surface of the rear plate, the catches being spaced apart from each other and situated in alignment with corresponding channels formed in the side walls of the main body of the housing, each U-shaped catch at least partially defining a slot for receiving one of the protruding flanges of the fastener of the interlock

19

piece to help hold the interlock piece in place at least partially within an elongated channel of a respective side wall of the main body of the housing in which the interlock piece is at least partially received.

21. A modular arrangement of a plurality of lighting fixtures, adjacent lighting fixtures being joined together, each lighting fixture comprising:

a housing, the housing including a main body having an overall polygonal shape and including a plurality of generally planar side walls, the main body defining an interior space, each side wall of the polygonally-shaped main body of the housing having an outer surface and an elongated channel formed in the outer surface; and

an interlock piece, the interlock piece having an elongated member which is at least partially receivable by the elongated channel formed in each side wall of the main body of the housing to interconnect the lighting fixture with another, similarly-structured lighting fixture of the modular arrangement;

wherein the elongated channel formed in the outer surface of each side wall of the main body of the housing includes a dovetail transverse cross-sectional shape, each side wall of the main body having a recessed portion formed in the outer surface thereof and two laterally opposite portions which face each other and partly overhang the recessed portion, whereby the recessed portion of each side wall and the two laterally opposite portions of the each side wall at least partially define the elongated channel formed in the outer surface of each side wall of the main body.

20

22. A modular arrangement of a plurality of lighting fixtures, adjacent lighting fixtures being joined together, each lighting fixture comprising:

a housing, the housing including a main body having an overall polygonal shape and including a plurality of generally planar side walls, the main body defining an interior space, each side wall of the polygonally-shaped main body of the housing having an outer surface and an elongated channel formed in the outer surface; and

an interlock piece, the interlock piece having an elongated member which is at least partially receivable by the elongated channel formed in each side wall of the main body of the housing to interconnect the lighting fixture with another, similarly-structured lighting fixture of the modular arrangement;

wherein the interlock piece includes a generally elongated member having a pair of laterally conjoined tubular members, the elongated member having a first axial end and a second axial end disposed opposite the first axial end, each tubular member having a first axial end situated in proximity to the first axial end of the elongated member, and a second axial end situated opposite the first axial end of the tubular member, the interlock piece further including a resilient cushioning piece situated at the first axial end of each tubular member, and a rotatable fastener mounted on the second axial end of the elongated member.

* * * * *