



US008789577B2

(12) **United States Patent**
Caldwell

(10) **Patent No.:** **US 8,789,577 B2**

(45) **Date of Patent:** **Jul. 29, 2014**

(54) **PORTABLE COLLAPSIBLE MODULAR
BACKGROUND SET AND METHOD OF USE**

(76) Inventor: **Ellen Caldwell**, Memphis, TN (US)

(*) Notice: Subject to any disclaimer, the term of this patent is extended or adjusted under 35 U.S.C. 154(b) by 106 days.

(21) Appl. No.: **12/857,711**

(22) Filed: **Aug. 17, 2010**

(65) **Prior Publication Data**

US 2012/0046116 A1 Feb. 23, 2012

(51) **Int. Cl.**

A47H 7/00 (2006.01)
A47G 5/00 (2006.01)
A63G 31/00 (2006.01)
A63J 5/02 (2006.01)
A63J 1/02 (2006.01)

(52) **U.S. Cl.**

CPC **A63J 1/02** (2013.01)
USPC **160/350**; 160/351; 472/57

(58) **Field of Classification Search**

USPC 160/123, 135, 330, 333, 338, 350, 351,
160/352; 211/194, 206; 248/200, 200.1;
396/3; 40/605, 610; 52/7; 206/600
See application file for complete search history.

(56) **References Cited**

U.S. PATENT DOCUMENTS

4,561,798 A 12/1985 Elerin
4,582,003 A 4/1986 Valero
4,865,111 A * 9/1989 Perutz 160/135
4,871,076 A * 10/1989 Schramm 211/189
5,323,836 A 6/1994 Tuttle
5,537,766 A 7/1996 Nickens
5,611,384 A 3/1997 Carter
5,619,299 A * 4/1997 Fleming-Schaub 396/3
6,359,218 B1 3/2002 Koch
6,370,803 B1 4/2002 Burquest
6,401,947 B1 * 6/2002 Hu et al. 211/189

6,643,966 B2 11/2003 Schmitt
7,140,307 B1 11/2006 Wolbert
2005/0034409 A1 2/2005 Fritsche
2005/0066592 A1 * 3/2005 Huber et al. 52/169.9
2006/0060310 A1 * 3/2006 Haugen 160/135
2010/0205901 A1 * 8/2010 Petta 52/831

OTHER PUBLICATIONS

Affordable Exhibit Displays; Website: <http://www.affordabledisplays.com/shopexd.asp?id=458> Affordable Exhibit Displays, Inc., 1967 Lisbon Road, Lewiston ME 04240 (USA).
Displayit; Website: <http://www.displayit.com/10-ft-Standard-Curved-Popup-Trade-Show-Display.aspx>; Displayit, Inc., 130 Satellite Blvd, NE, Suite E, Suwanee, GA 30024 (USA).
Siegel Display Products; Web: <http://www.siegeldisplay.com/productdetail.aspx?id=t6005-48237> Siegel Display Products, 300 Sixth Ave. North, Suite 200, Minneapolis, MN 55401 (USA).
Camelback Displays, Inc.; Website: <http://www.camelbackdisplays.com/Fabric-Pop.htm> Camelback Displays, Inc., 1922 Willow Wisp Ln., Spring, TX 77388 (USA).

* cited by examiner

Primary Examiner — Katherine Mitchell

Assistant Examiner — Jeremy Ramsey

(74) Attorney, Agent, or Firm — Roy E. Williams

(57) **ABSTRACT**

This embodiment provides for a portable, easily-assembled, modular background set that can be used in television studios, theatre stages, and tradeshow booths, to name a few, and for displays in other settings, such as retail stores, physician's offices, and the like, that is, wherever information needs to be displayed. According to this embodiment, an apparatus and method for providing said background set or display comprises a plurality of base structures; a plurality of outer and inner collapsible corrugated plasticboard sleeves; a plurality of supporting frames; a hanger system; an elastic cord stabilizing system; and a collapsible backdrop system. These components are assembled from a very compact, collapsed, disassembled state in a quick and easy manner, with no special tools, to create a professional set or display that can be used in a plurality of different venues.

25 Claims, 60 Drawing Sheets

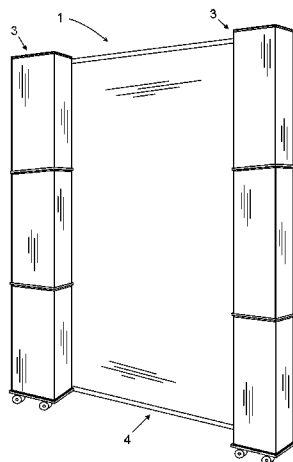

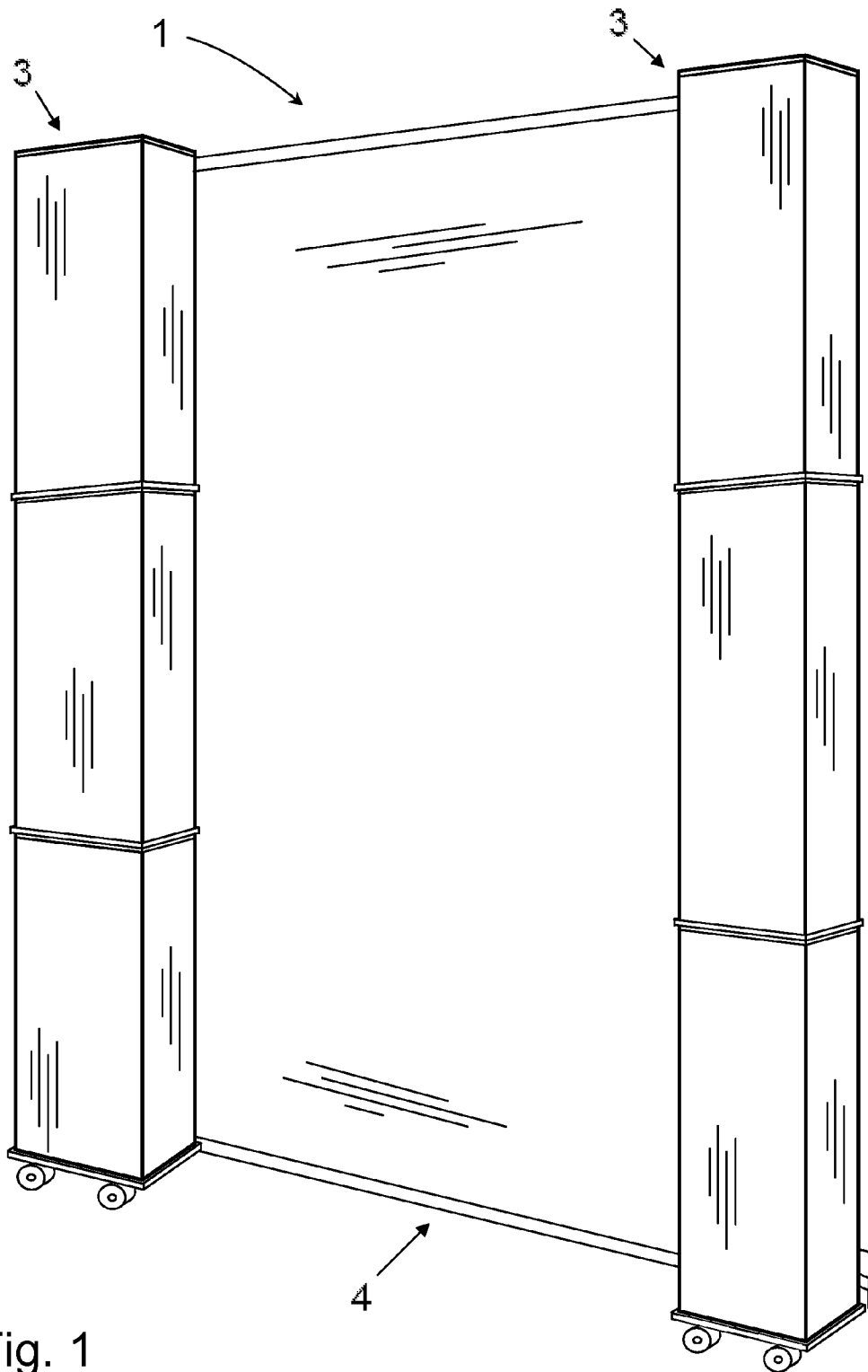

Fig. 1

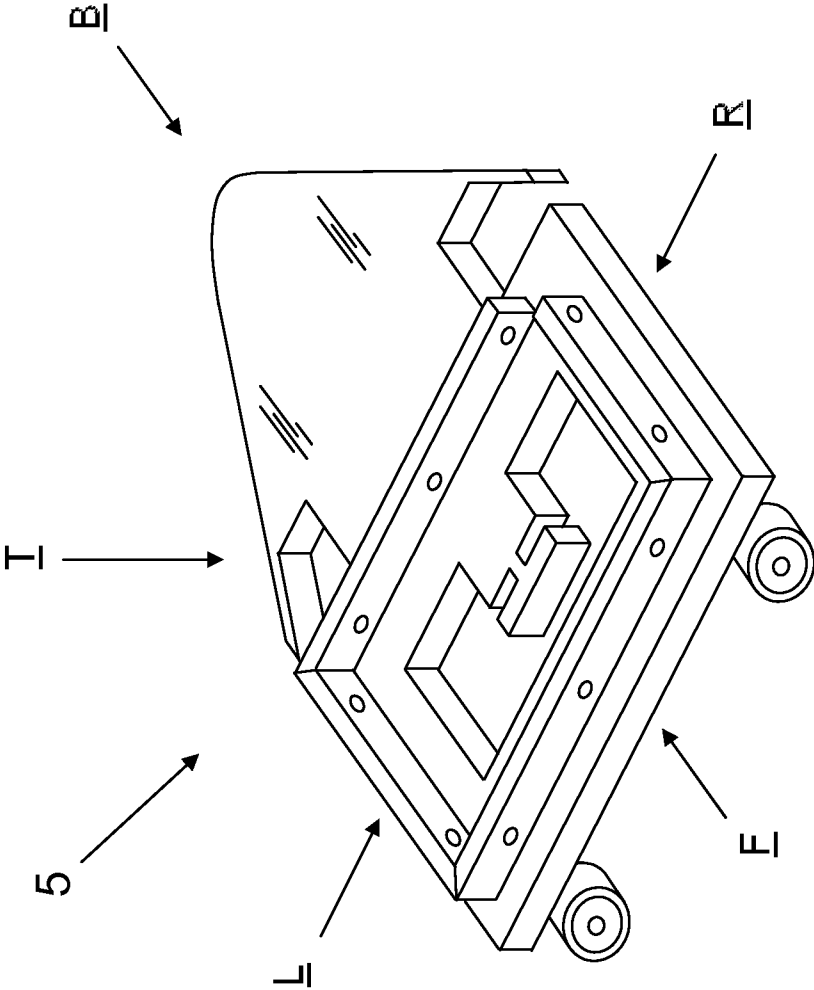

Fig. 2A

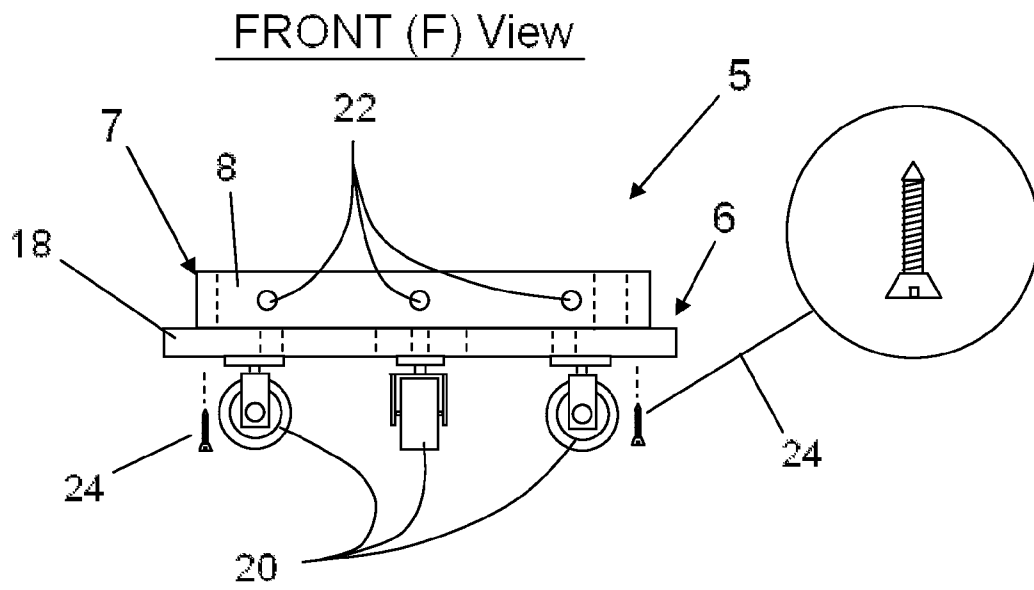

Fig. 2B

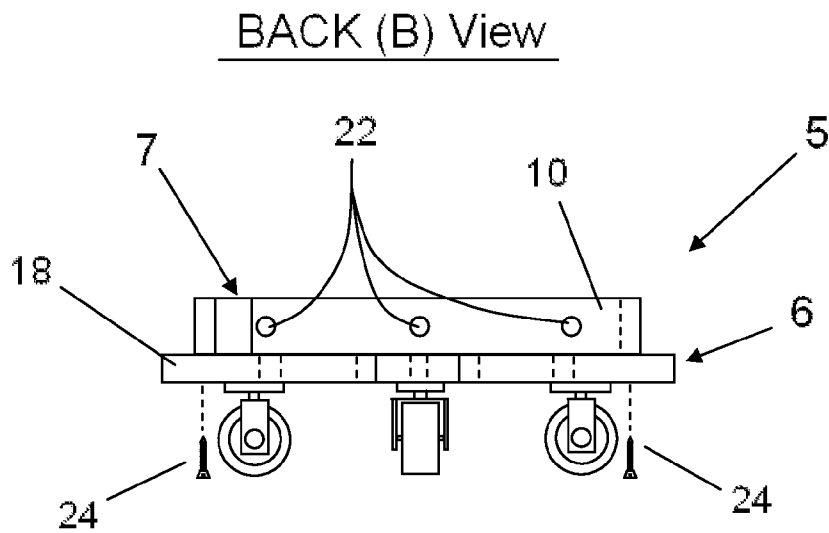

Fig. 2C

RIGHT (R) View

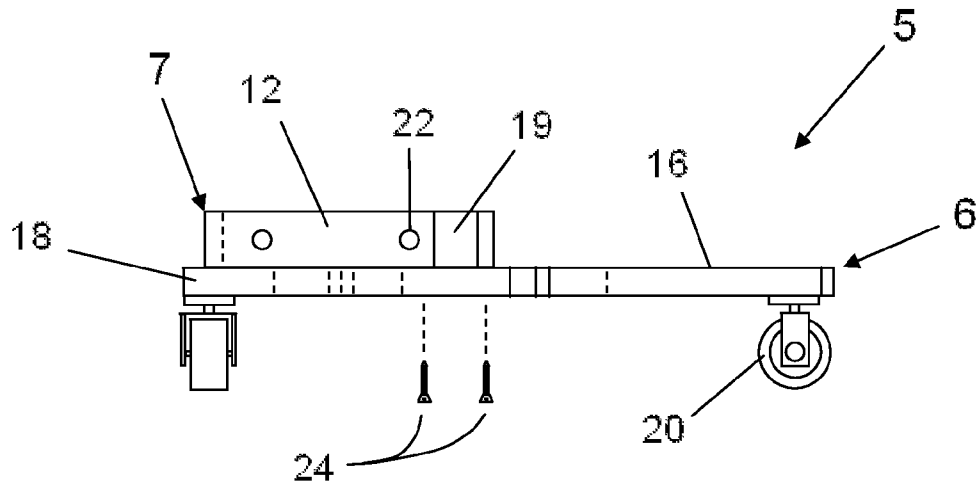

Fig. 2D

LEFT (L) View

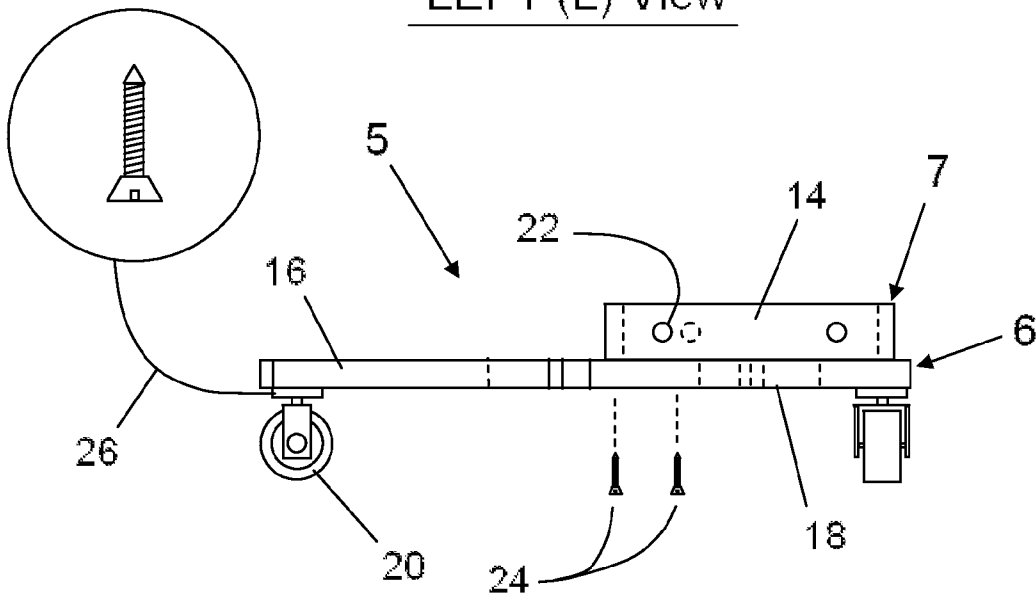

Fig. 2E

TOP (T) View

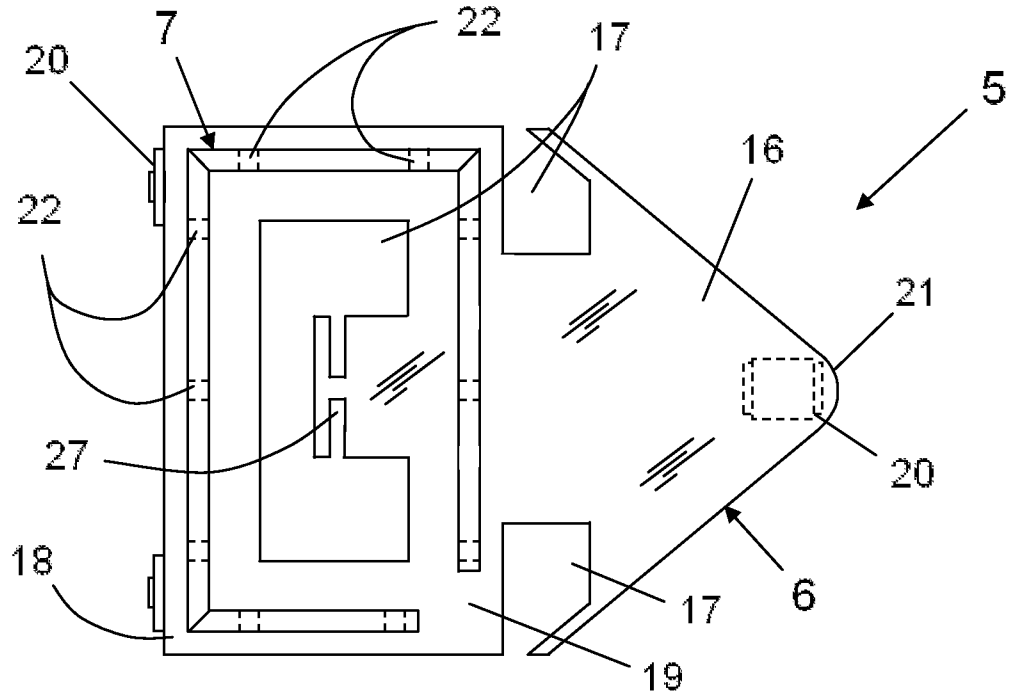

Fig. 2F

BOTTOM (B) View

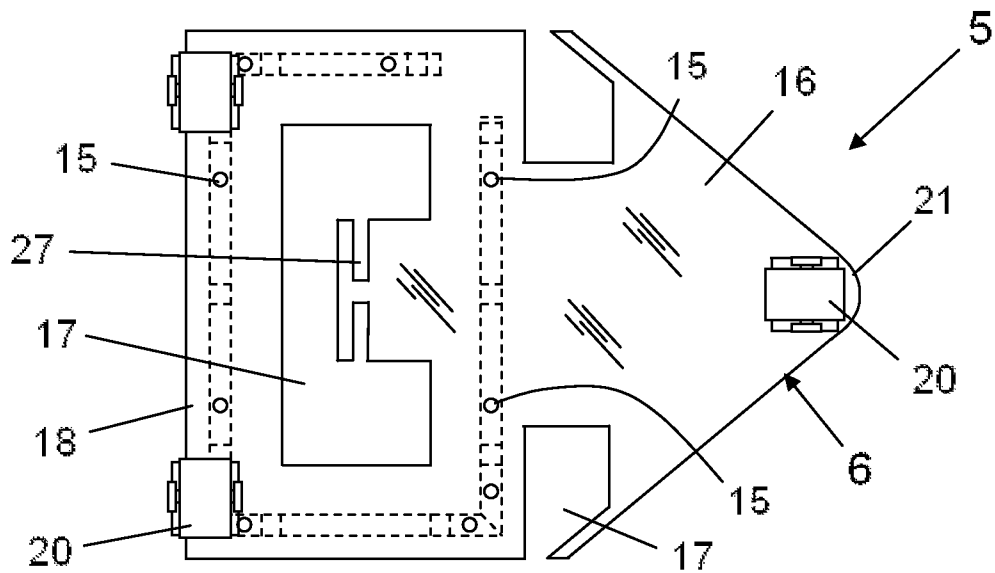

Fig. 2G

TOP (T) View

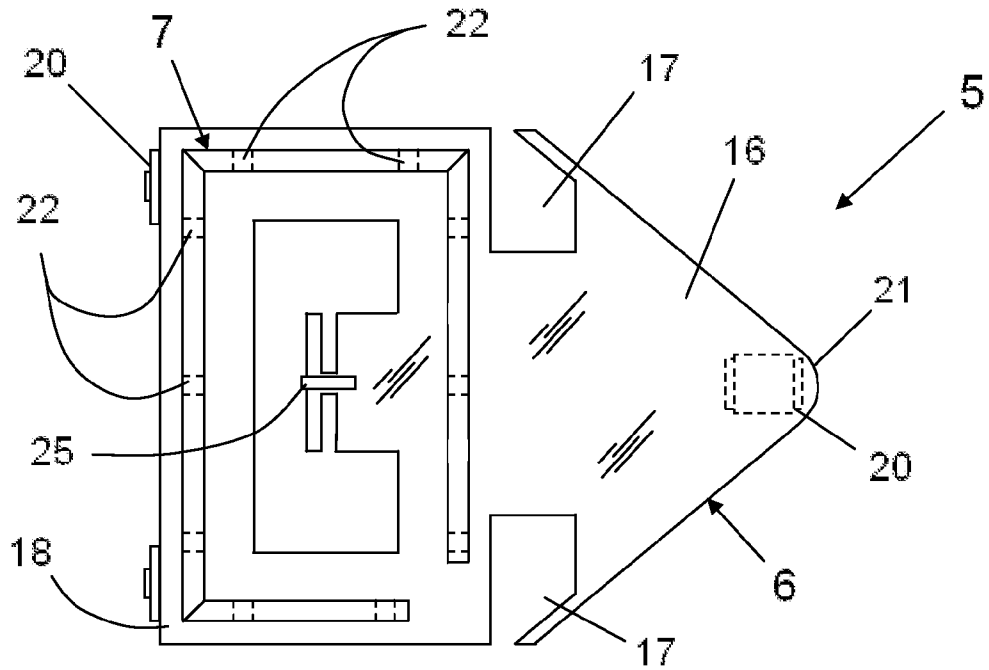

Fig. 2H

RIGHT (R) View

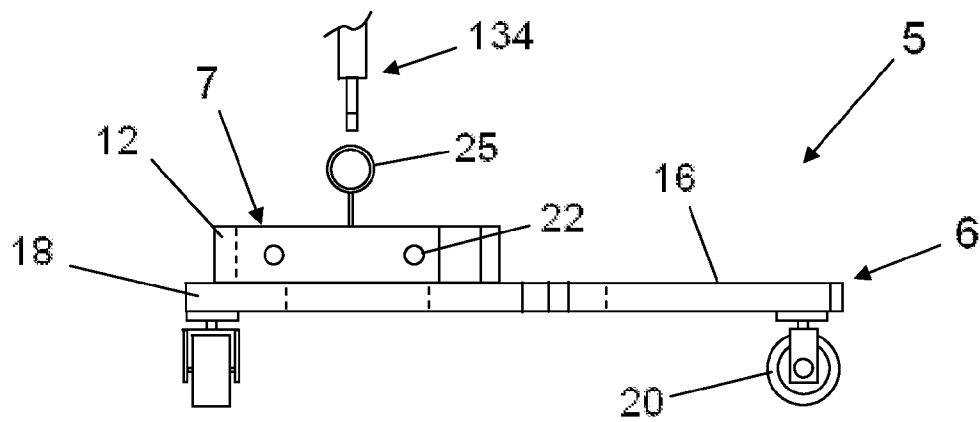

Fig. 2I

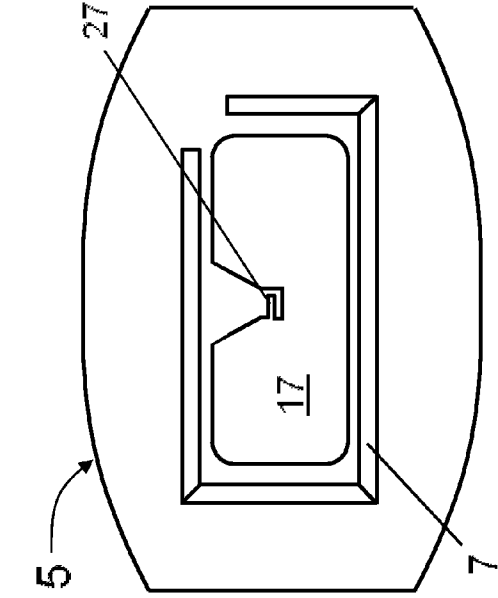

Fig. 2L

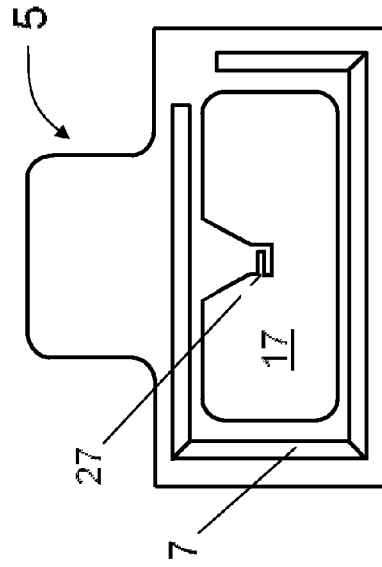

Fig. 2M

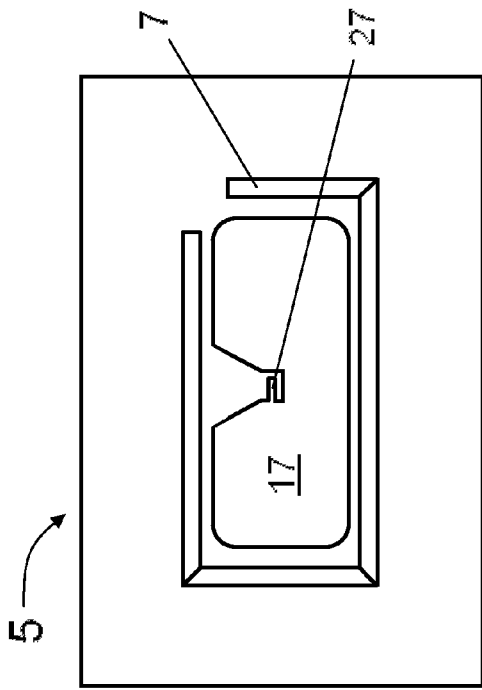

Fig. 2J

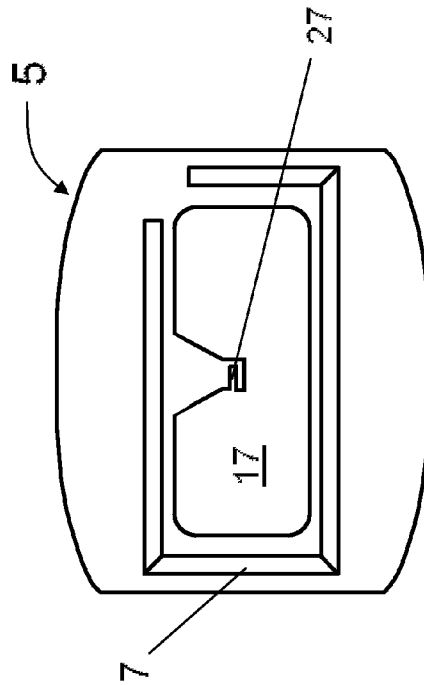

Fig. 2K

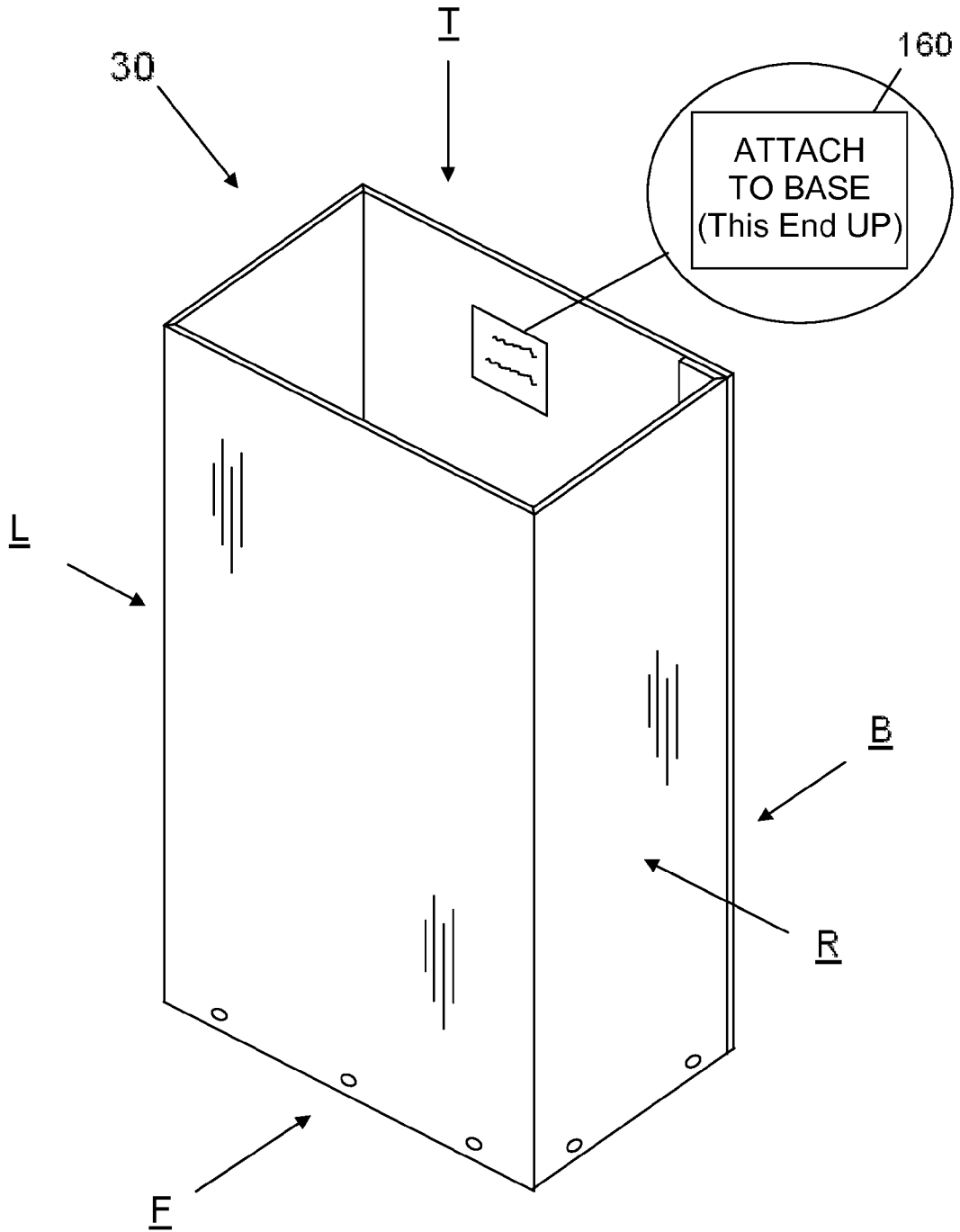

Fig. 3

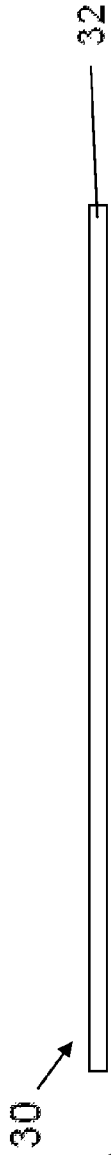

Fig. 4A

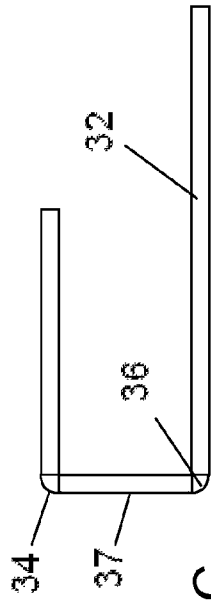

Fig. 4C

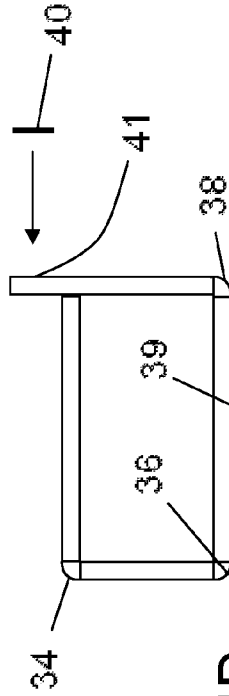

Fig. 4D

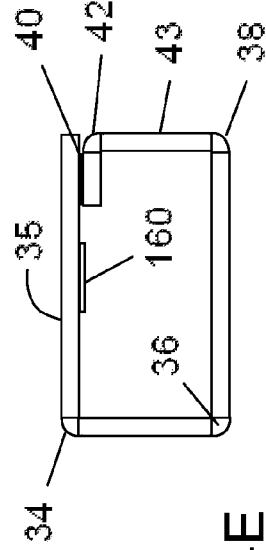

Fig. 4E

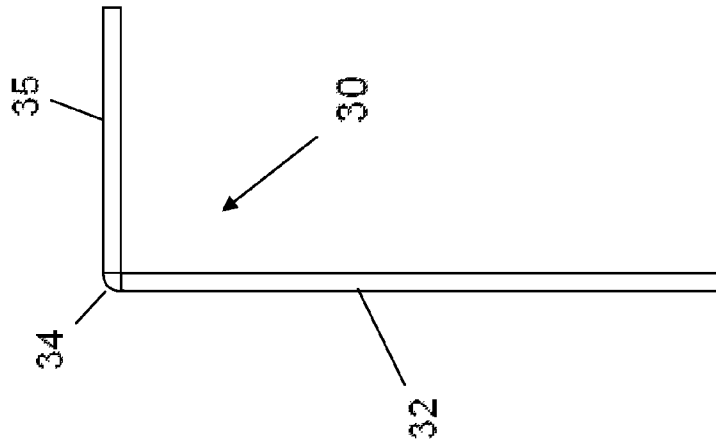

Fig. 4B

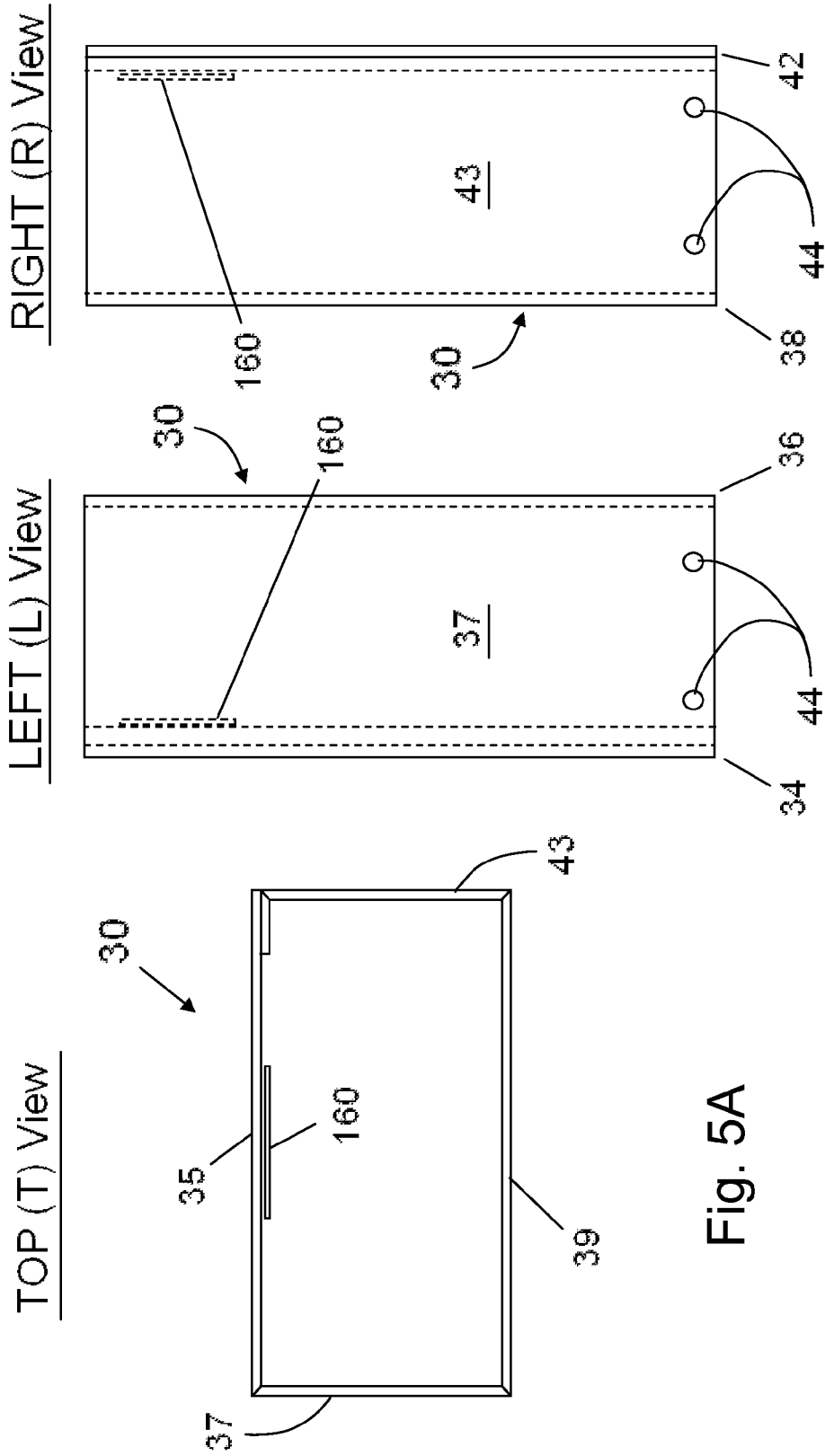

Fig. 5A

Fig. 5B

Fig. 5C

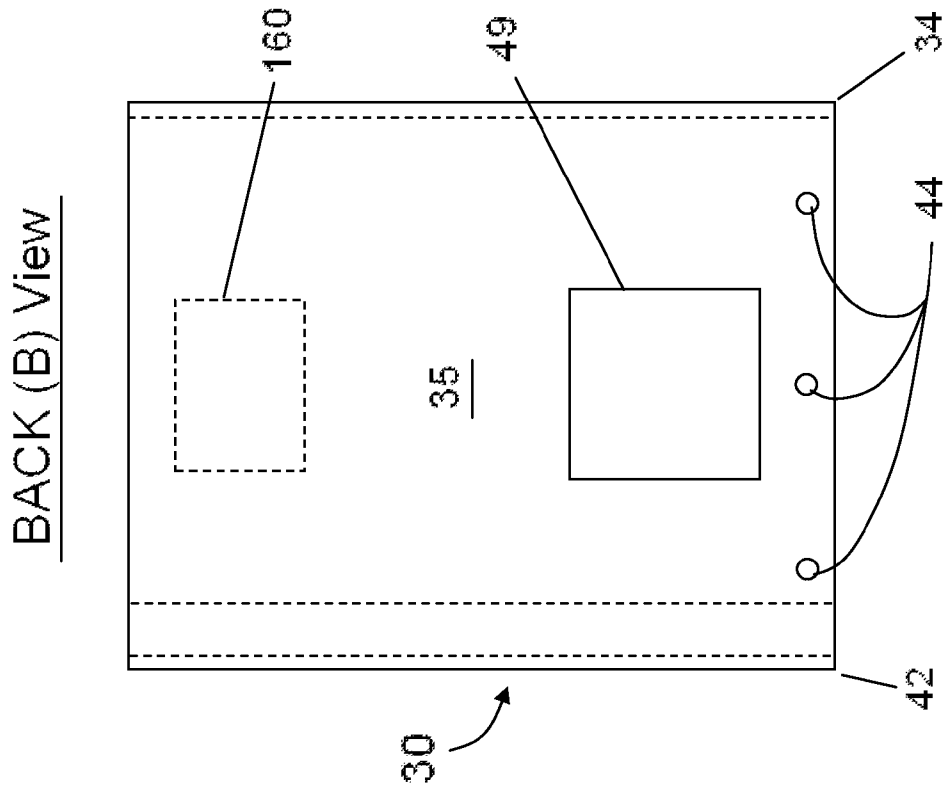

Fig. 5E

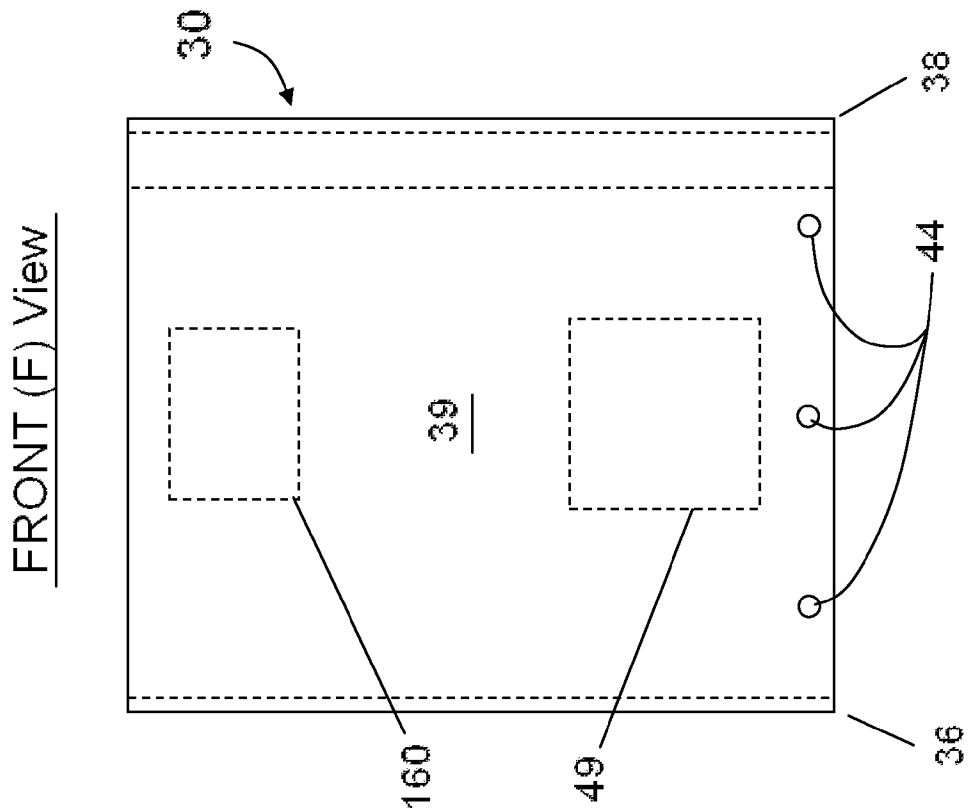

Fig. 5D

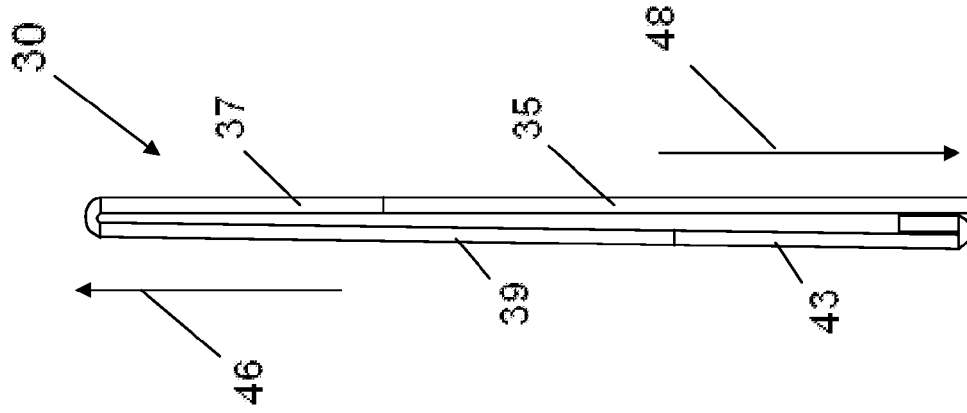

Fig. 6A

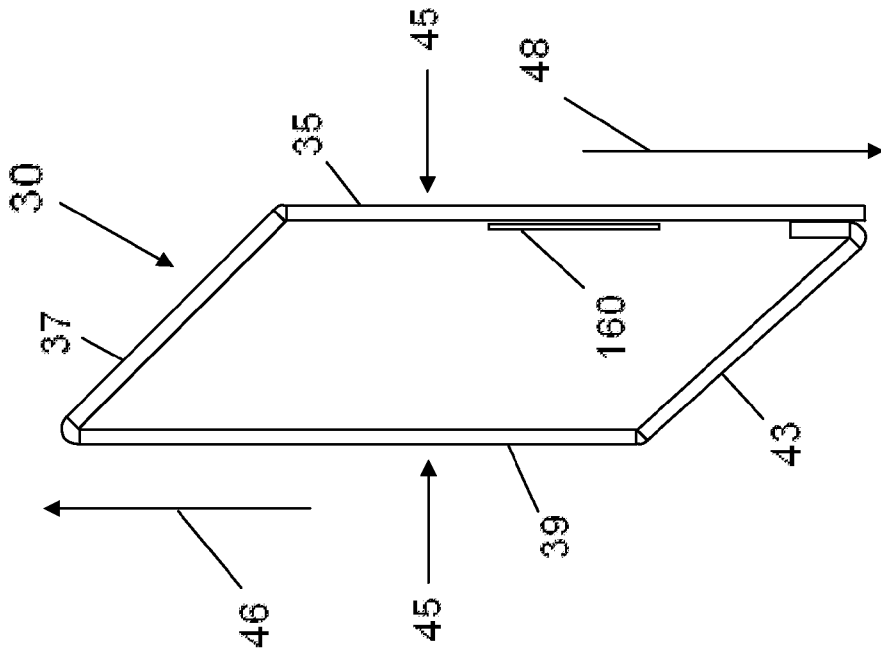

Fig. 6B

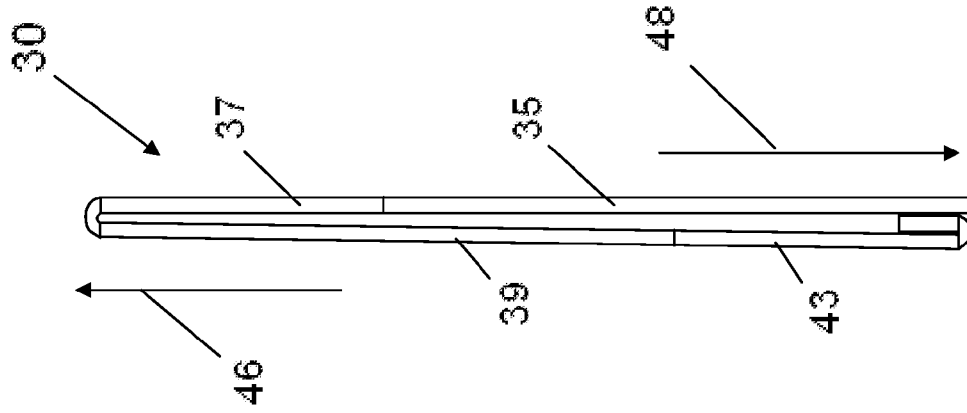

Fig. 6C

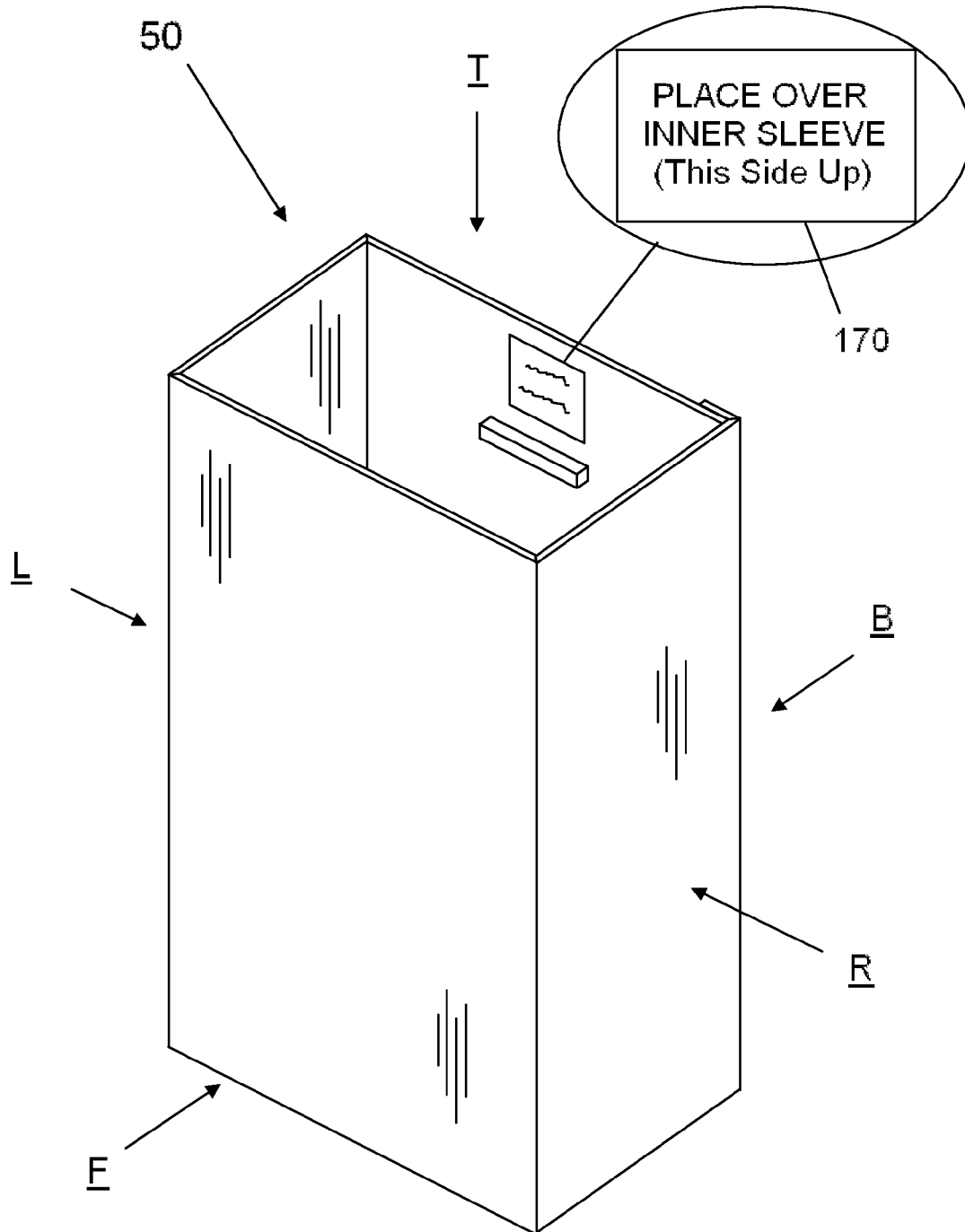

Fig. 7

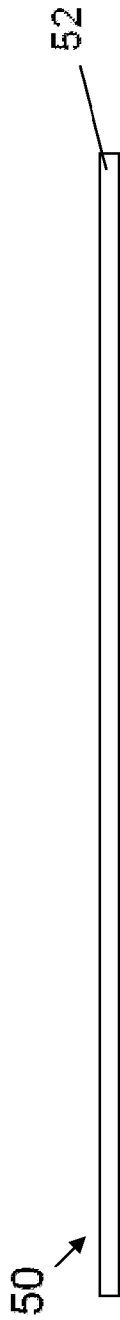

Fig. 8A

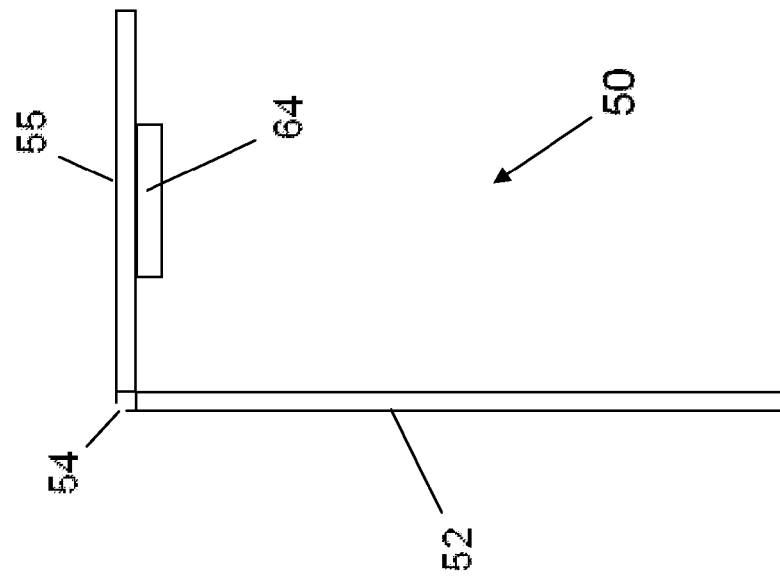

Fig. 8B

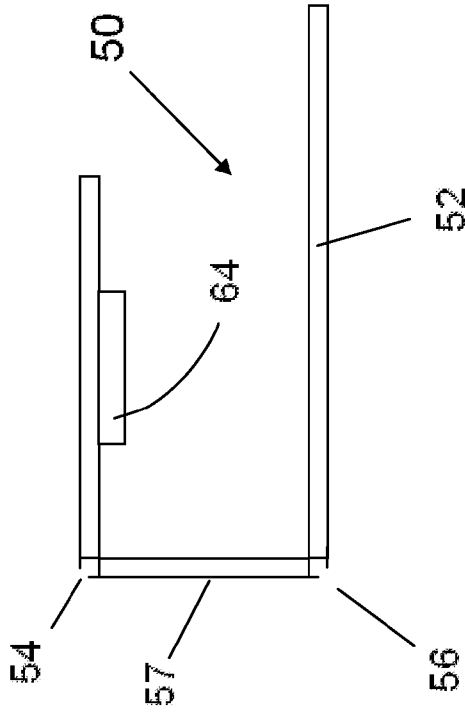

Fig. 8C

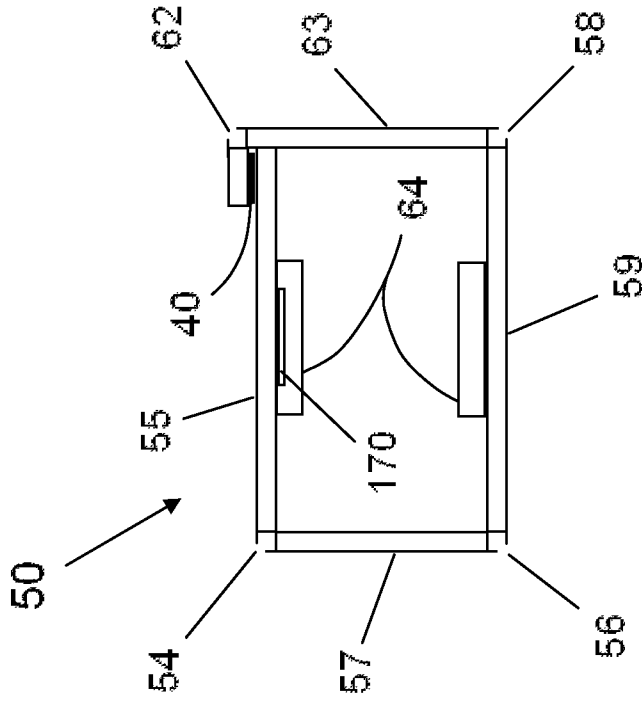

Fig. 8E

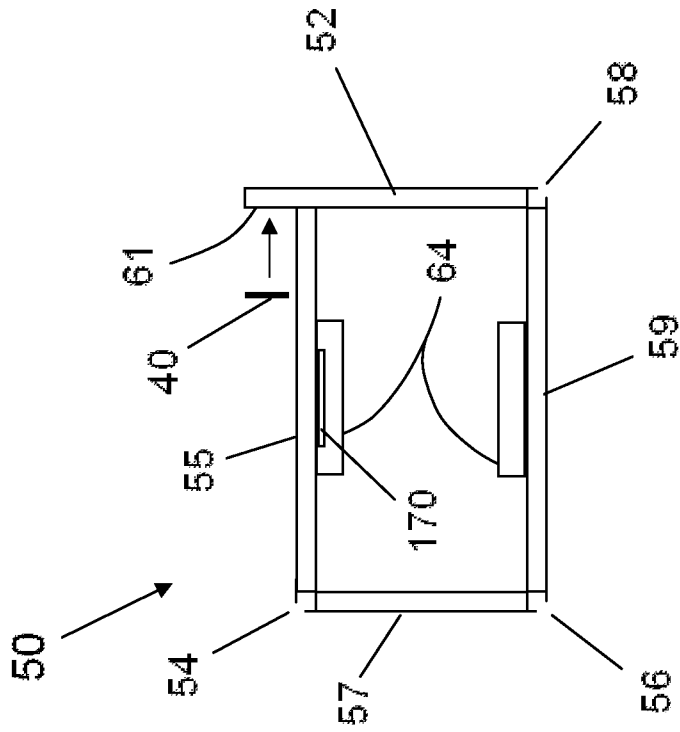

Fig. 8D

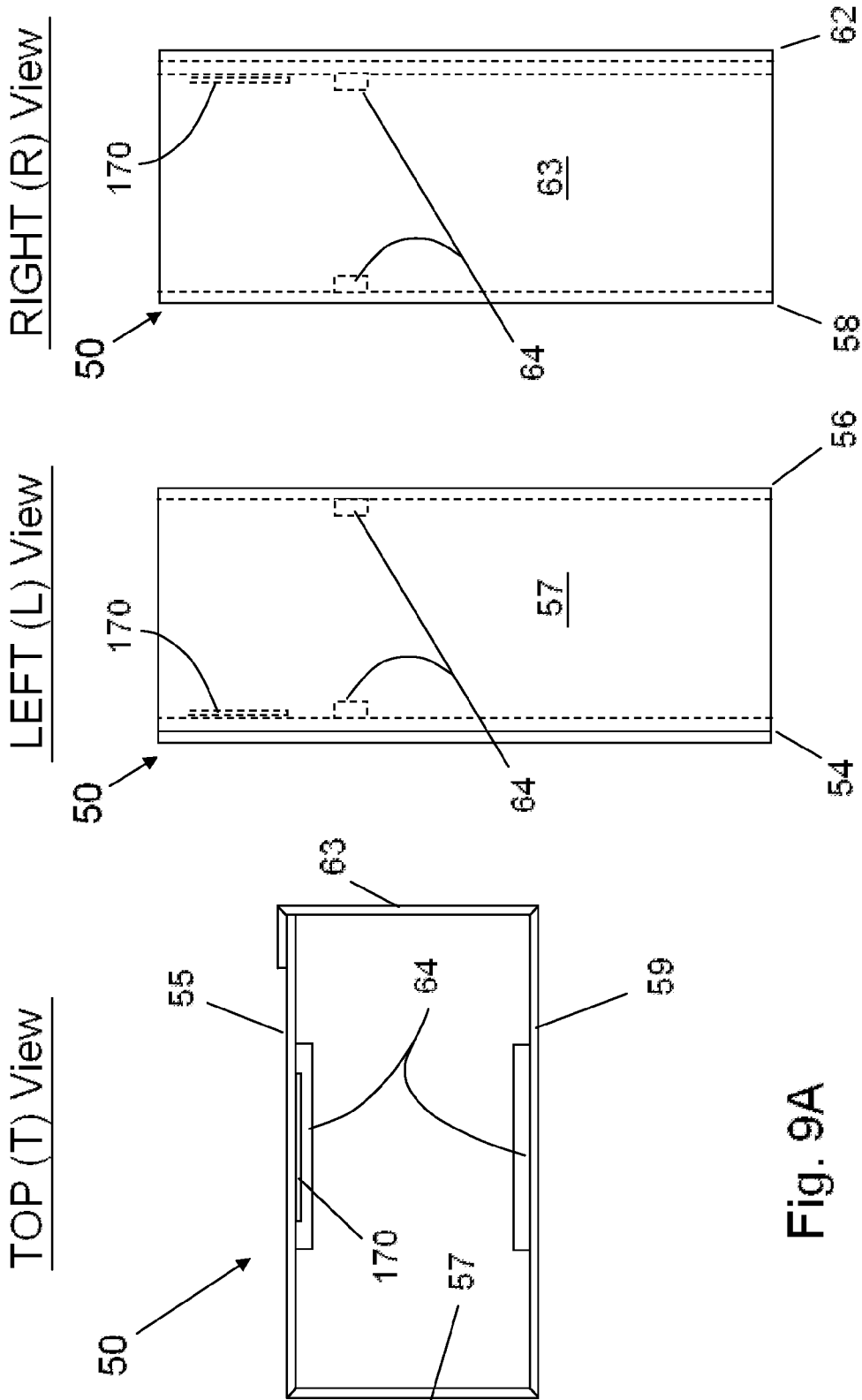

Fig. 9A

Fig. 9B

Fig. 9C

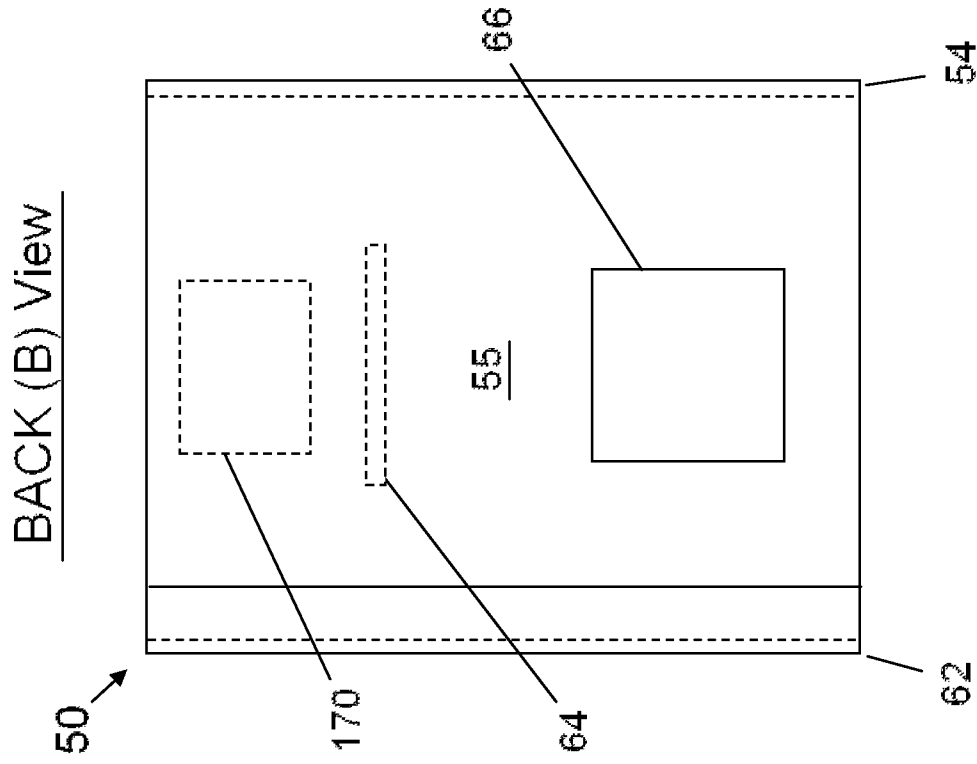

Fig. 9D

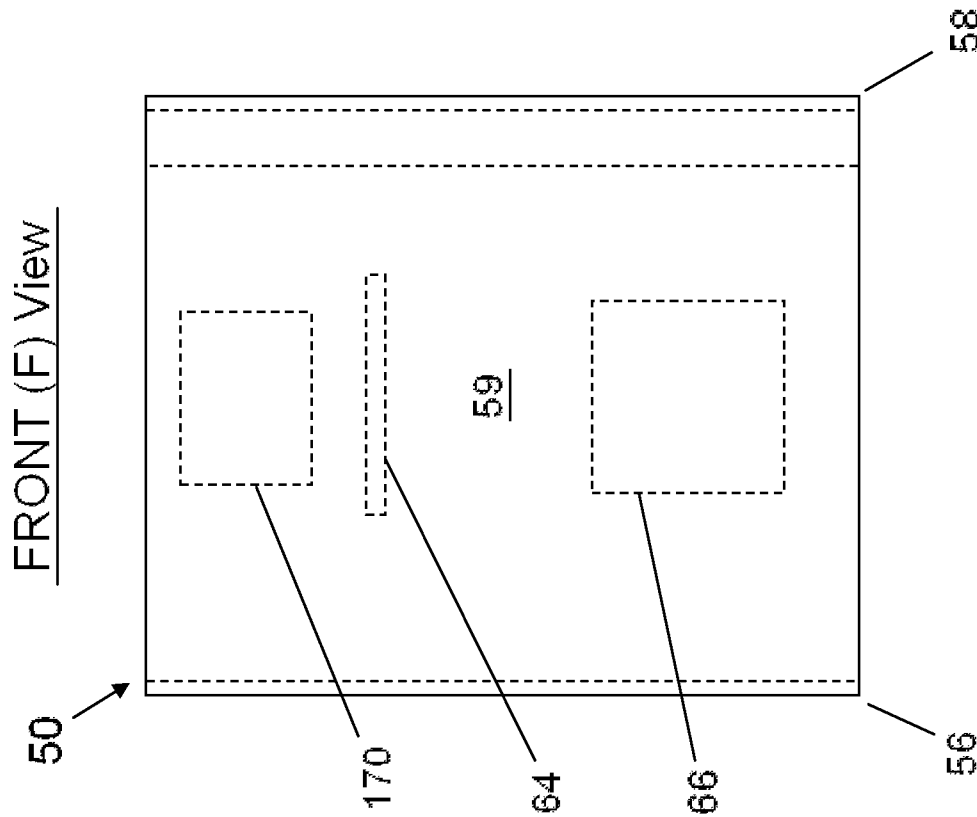

Fig. 9E

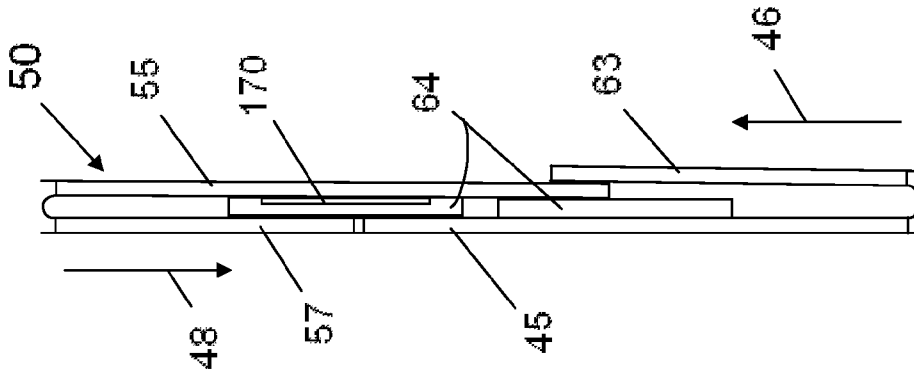

Fig. 10C

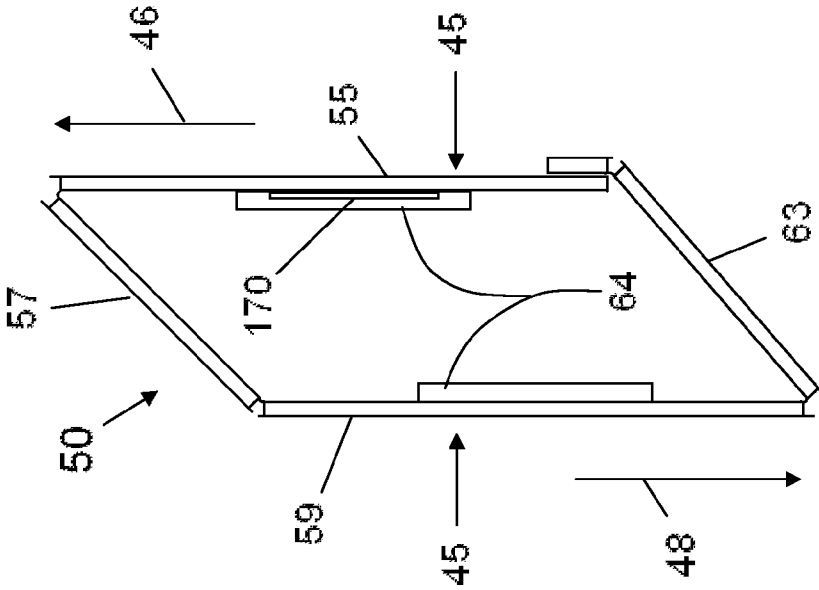

Fig. 10B

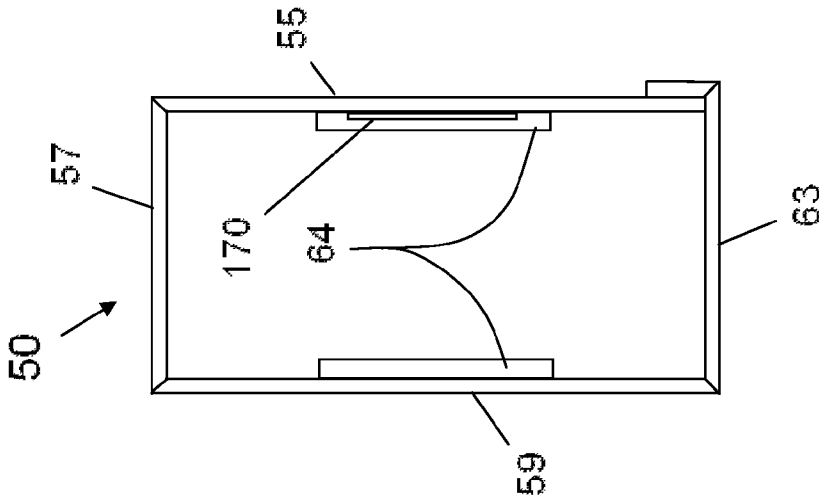

Fig. 10A

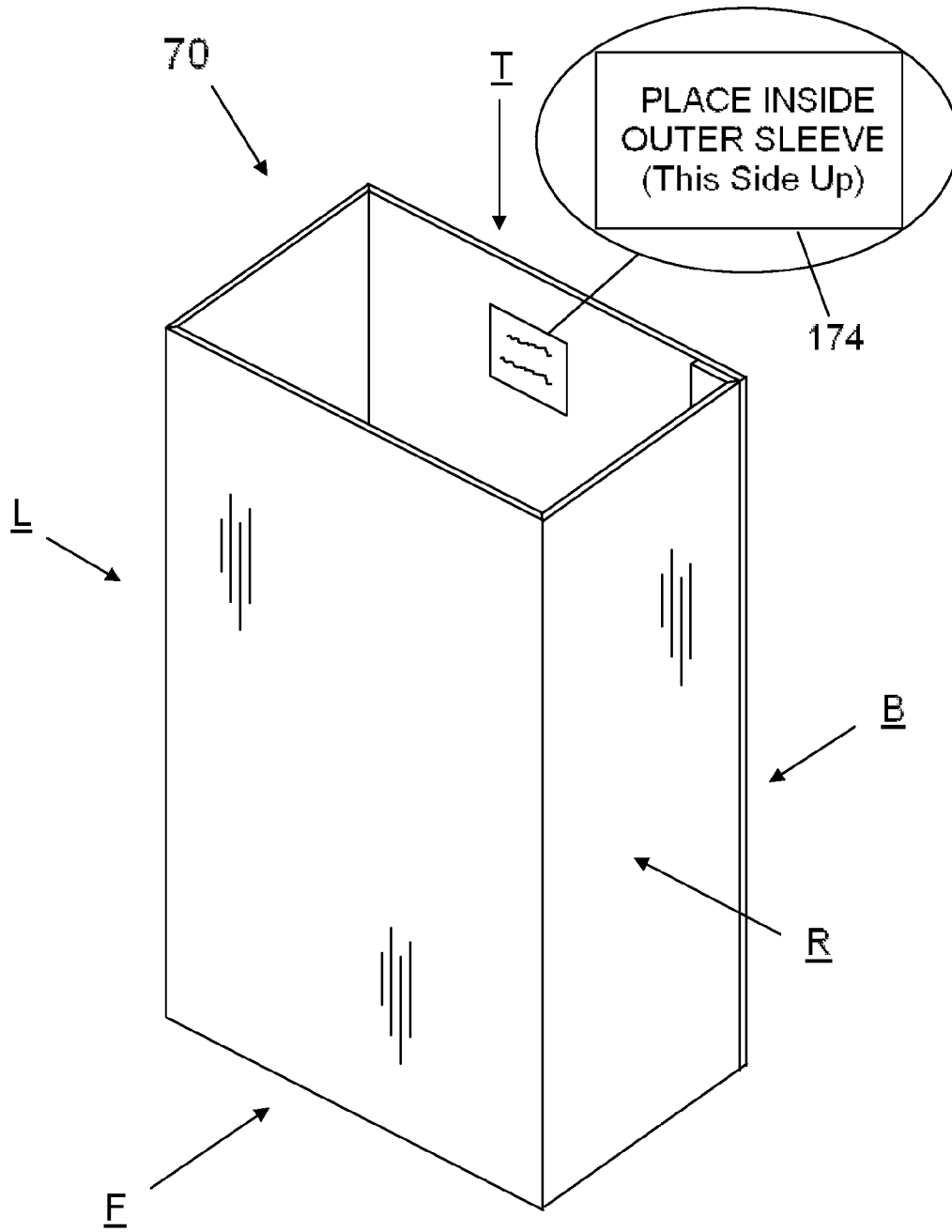

Fig. 11

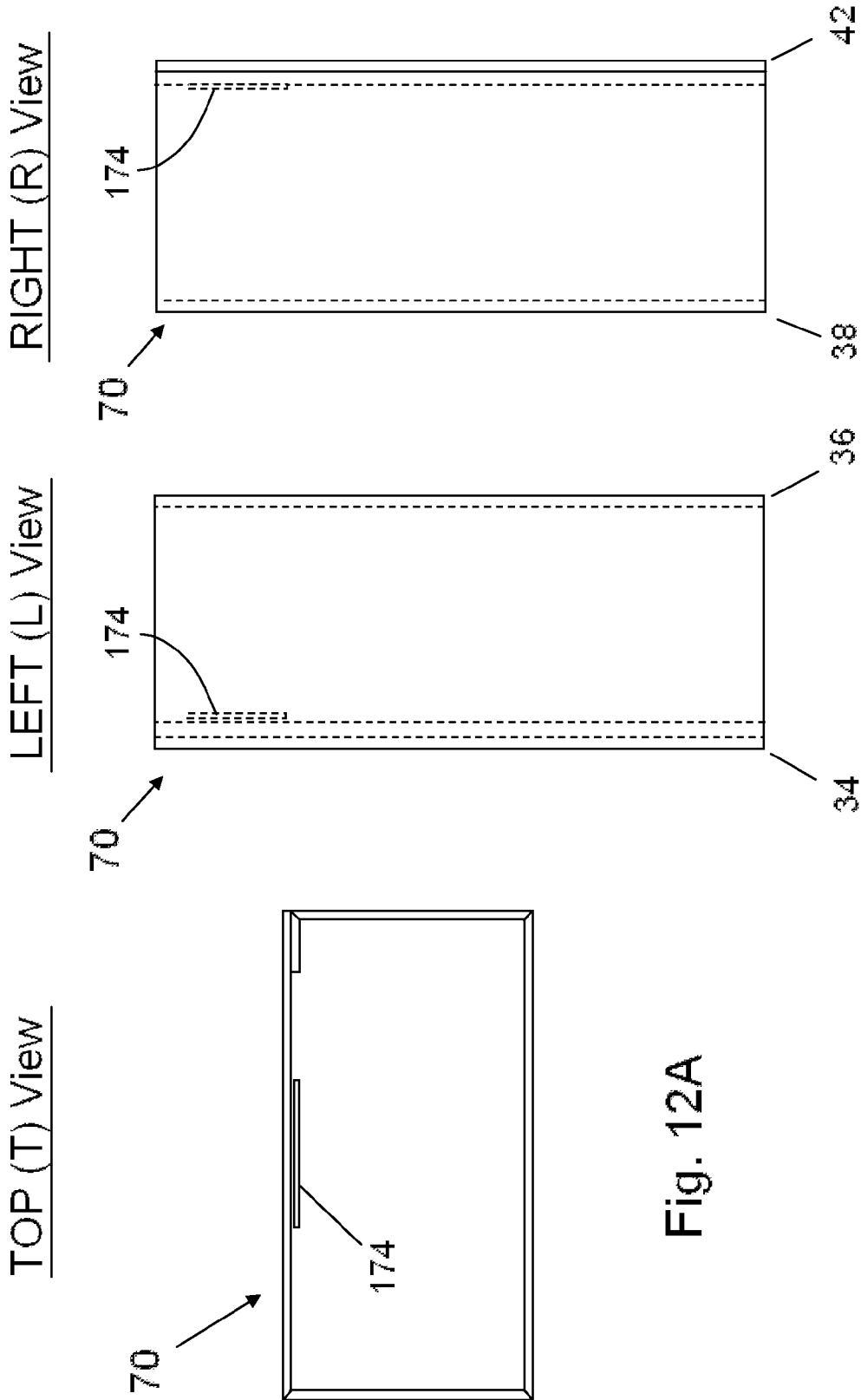

Fig. 12A

Fig. 12C

Fig. 12B

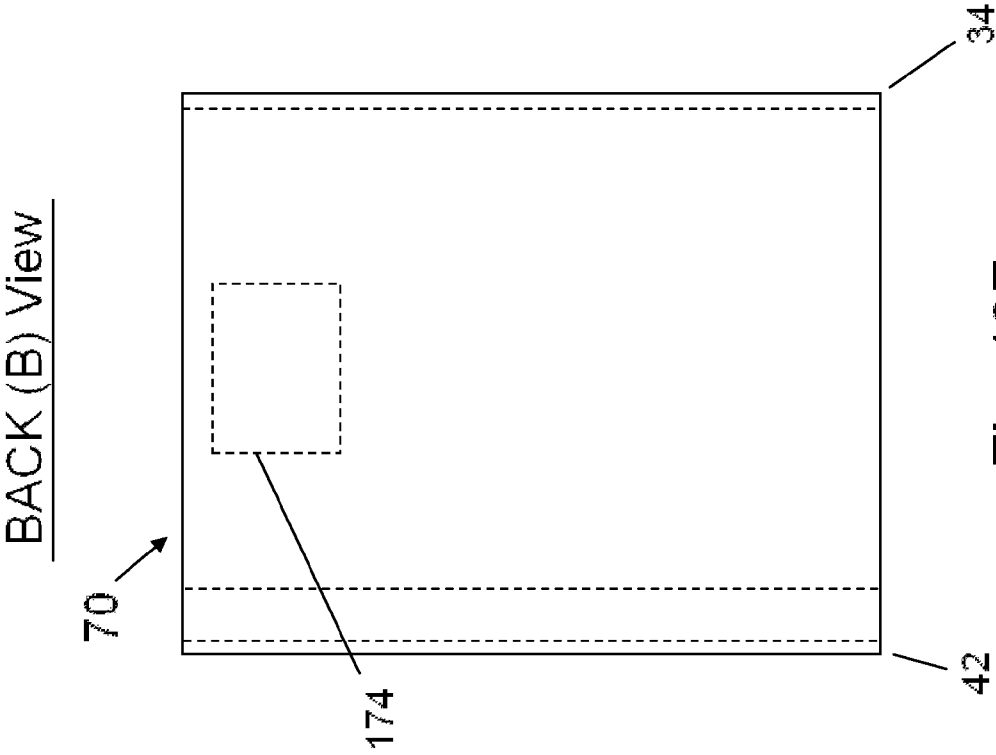

Fig. 12E

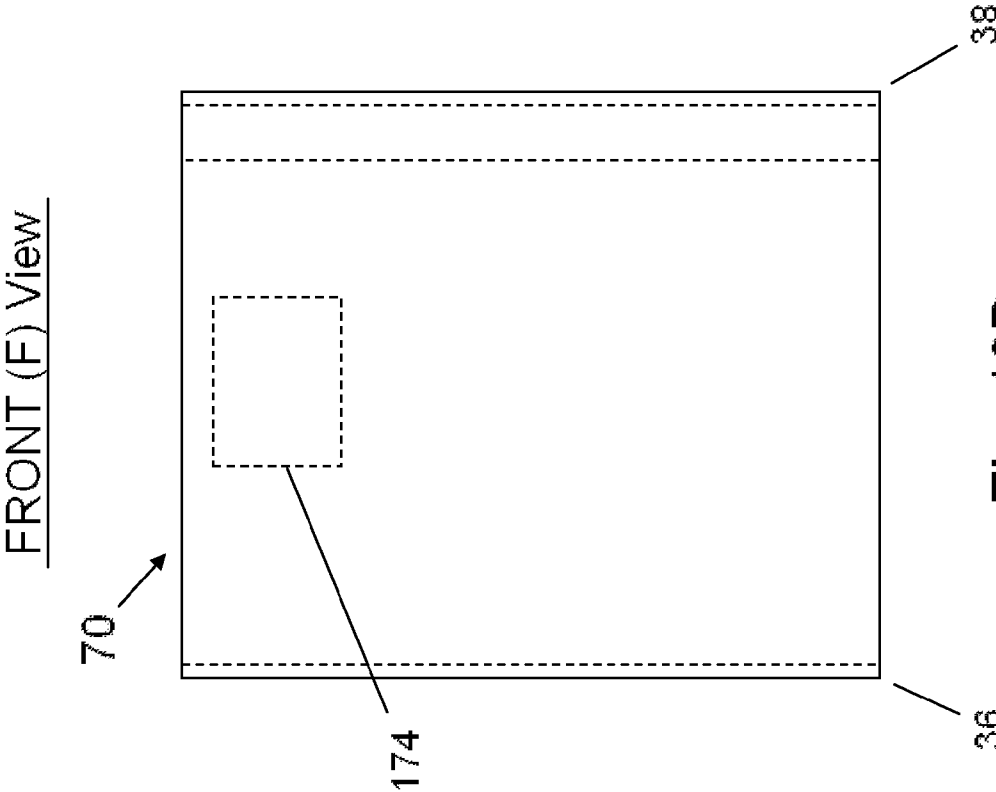

Fig. 12D

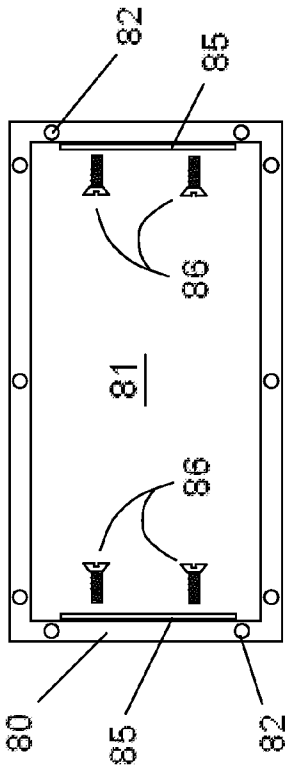

Fig. 13A

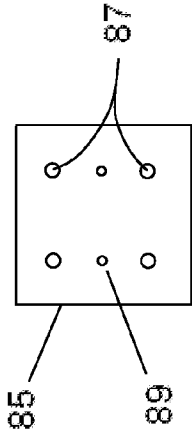

Fig. 13C

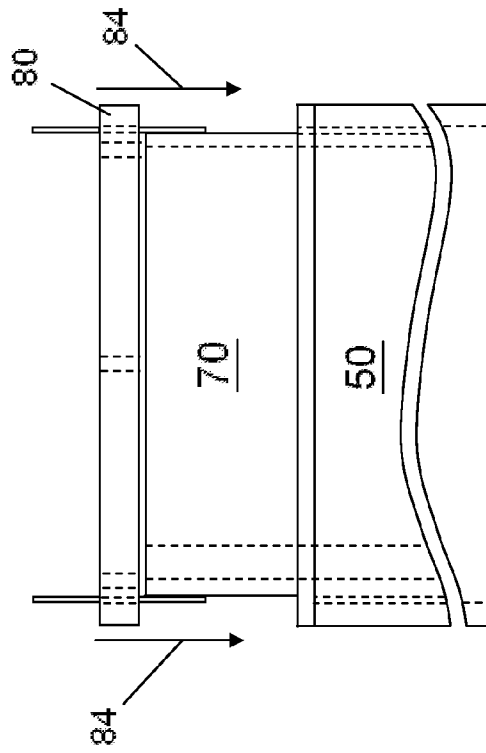

Fig. 13B

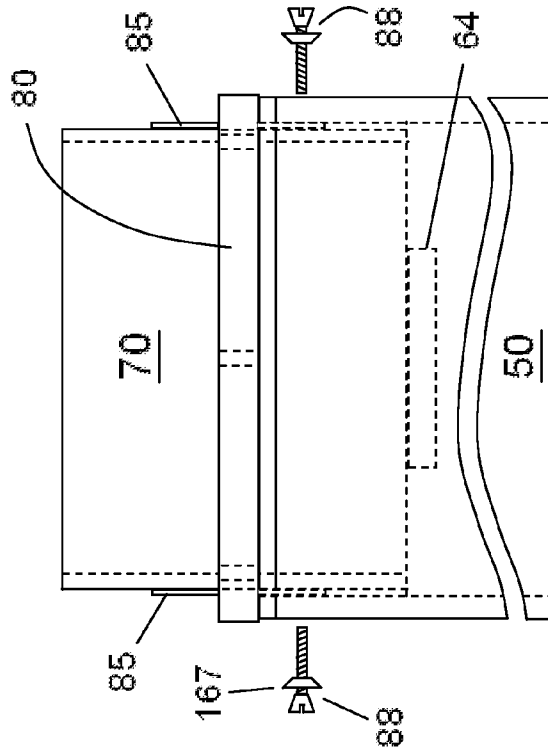

Fig. 13D

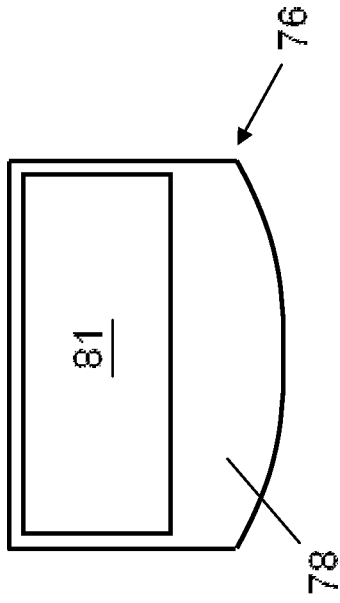

Fig. 13G

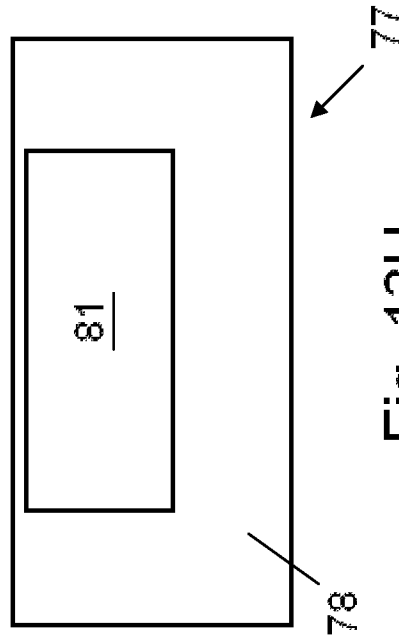

Fig. 13H

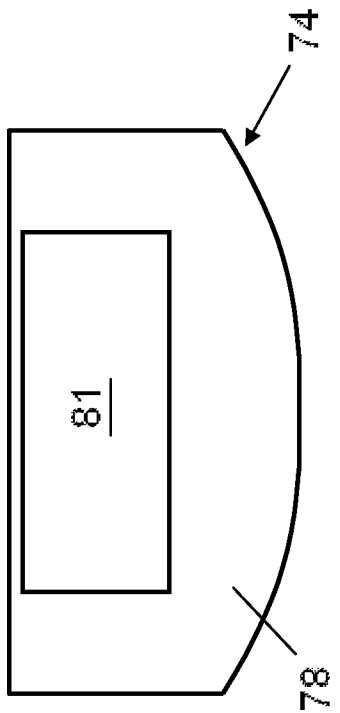

Fig. 13E

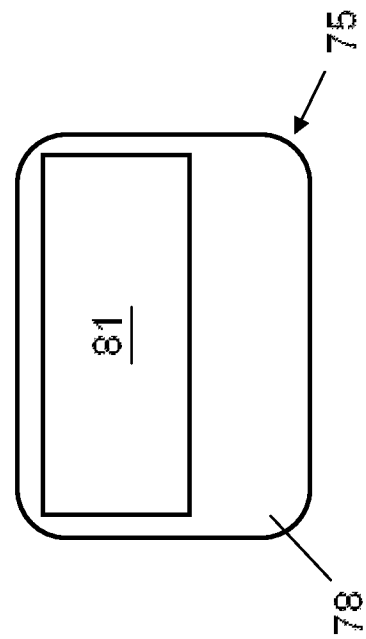

Fig. 13F

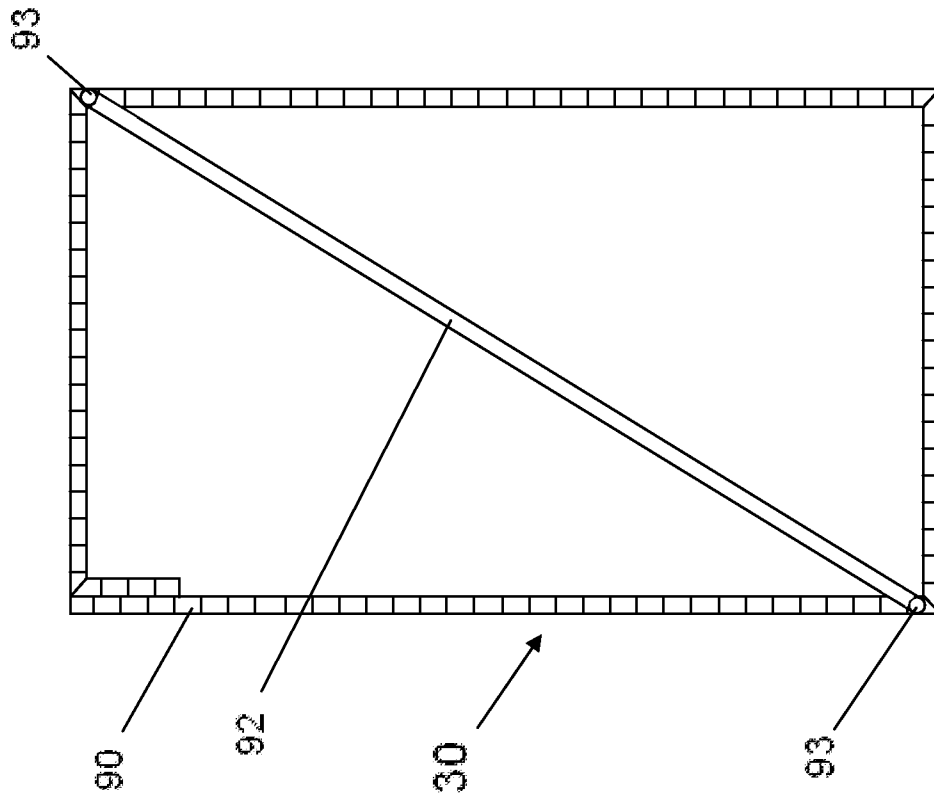

Fig. 14B

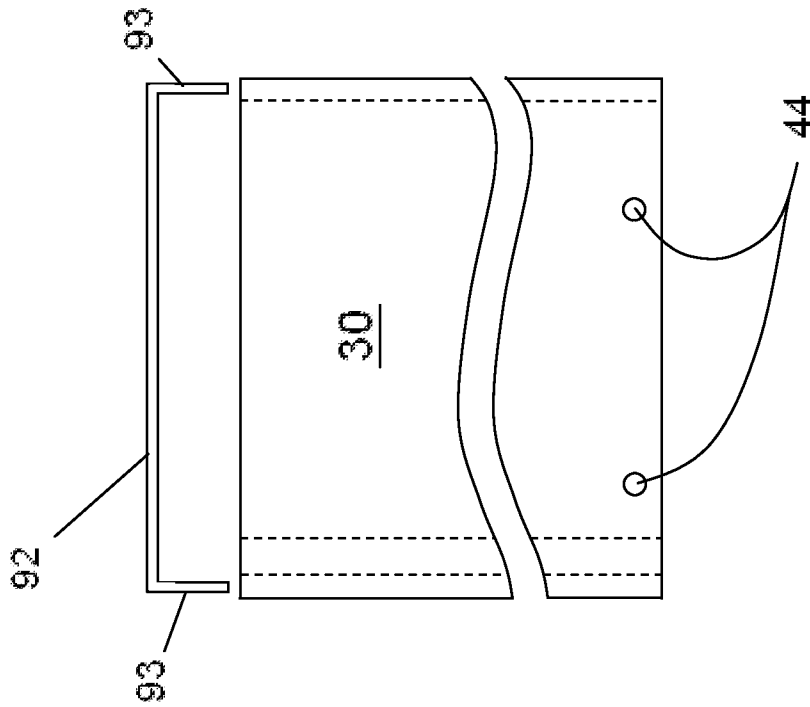

Fig. 14A

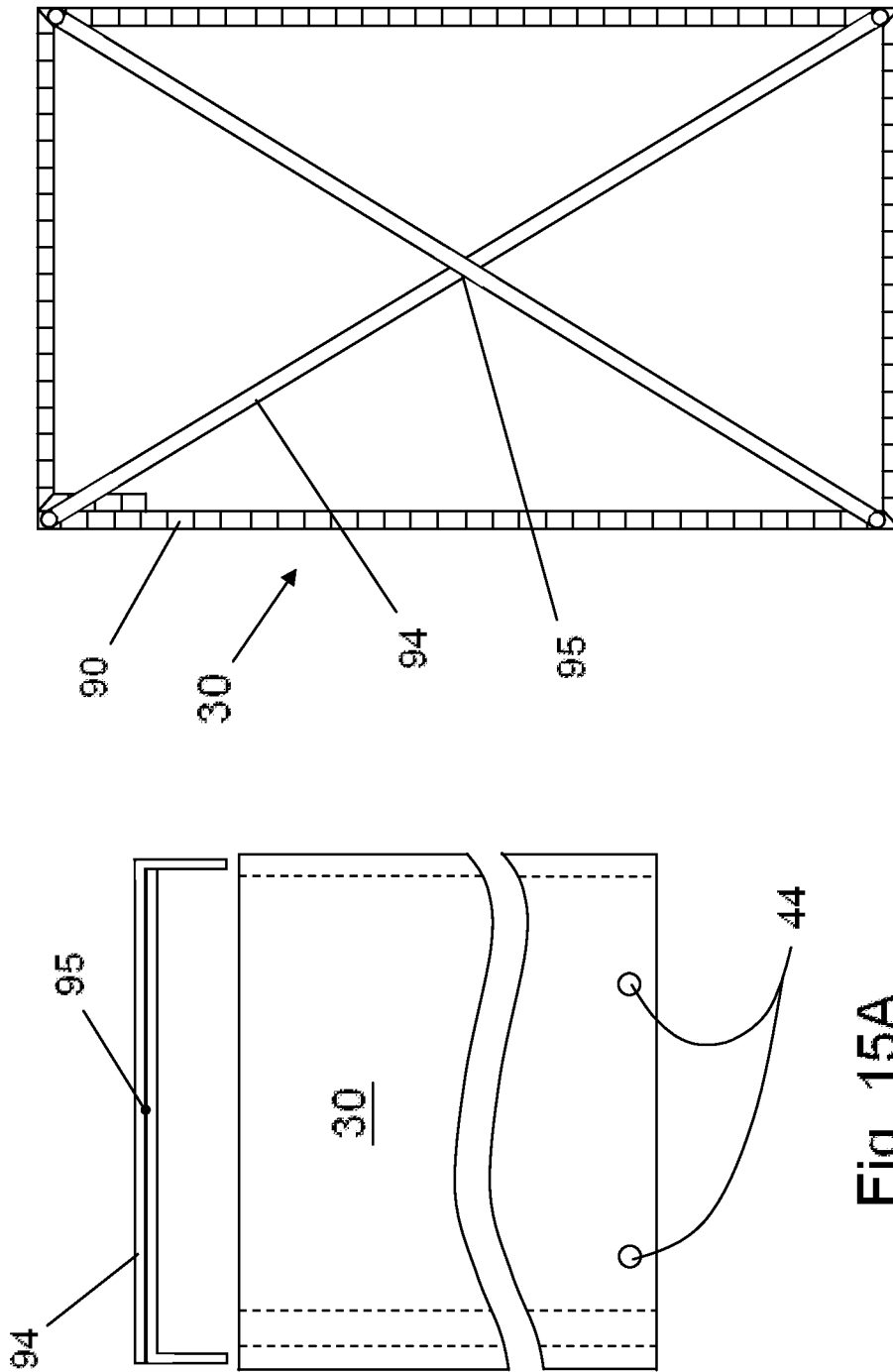

Fig. 15B

Fig. 15A

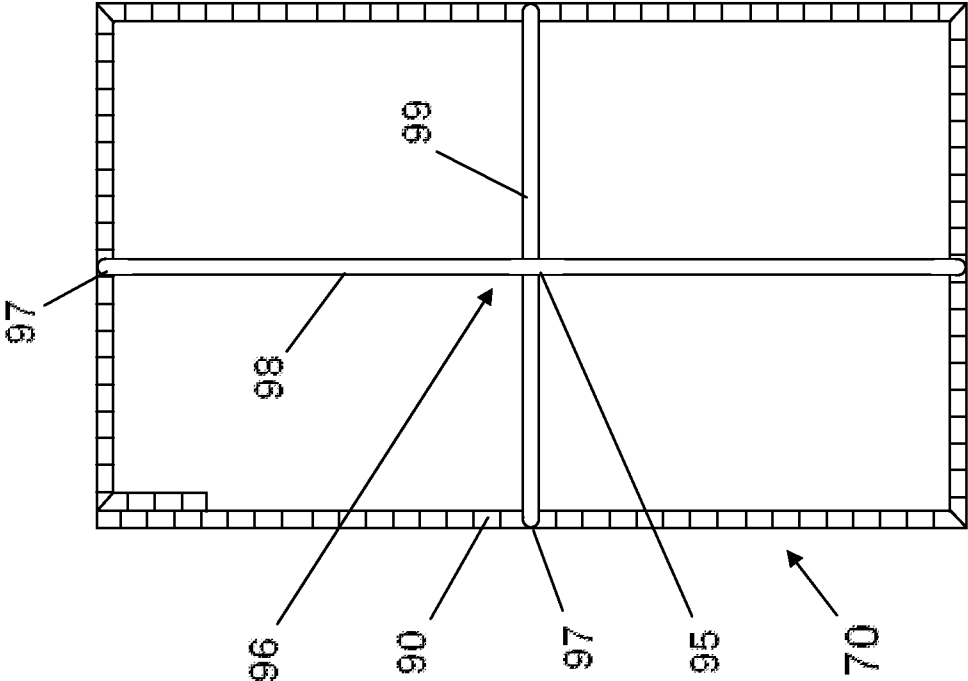

Fig. 16B

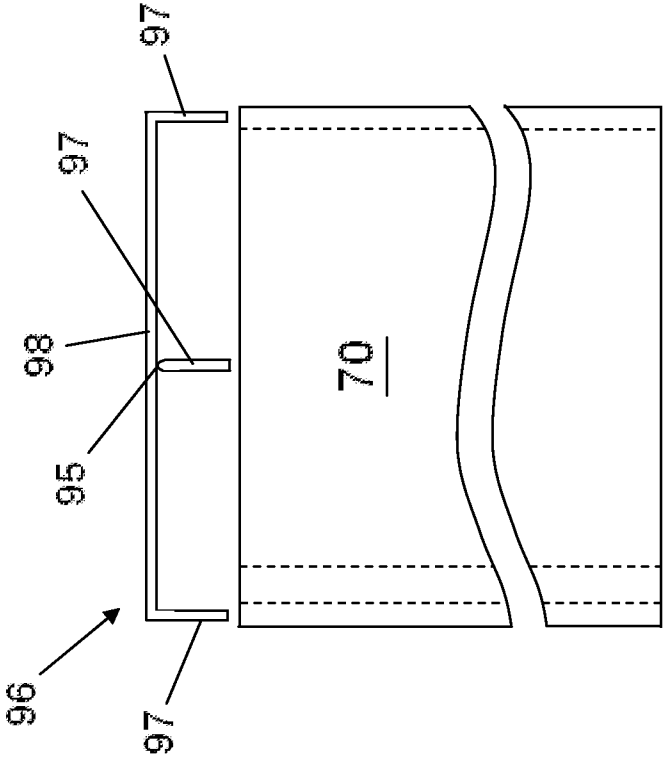

Fig. 16A

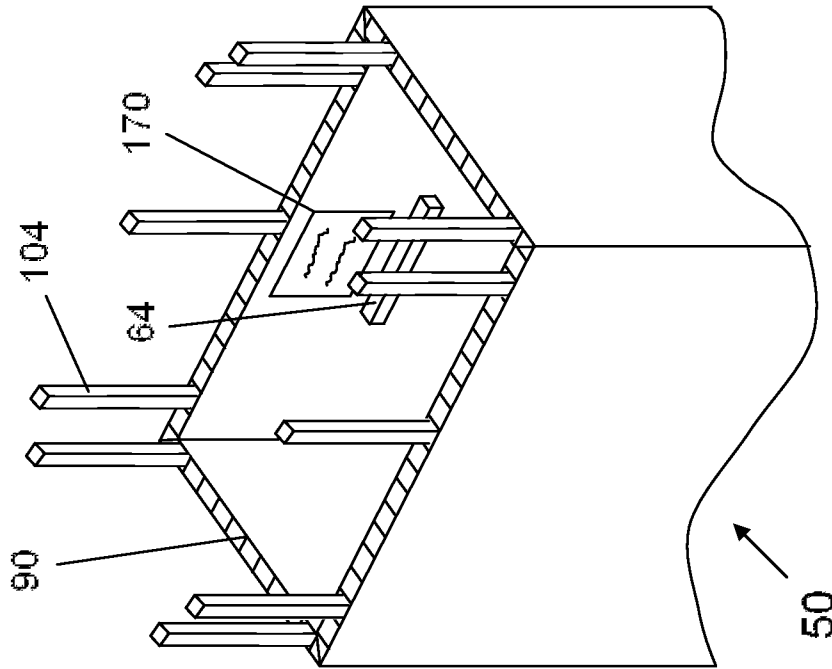

Fig. 17

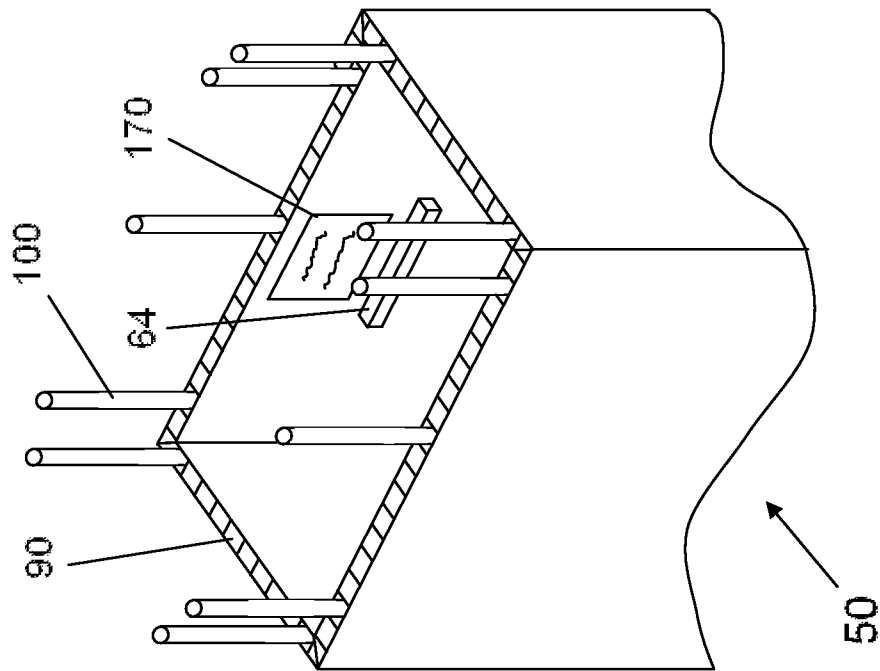

Fig. 18

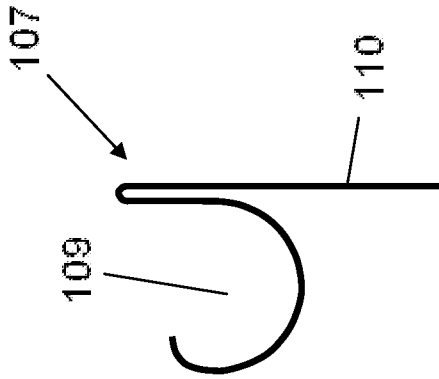

Fig. 20

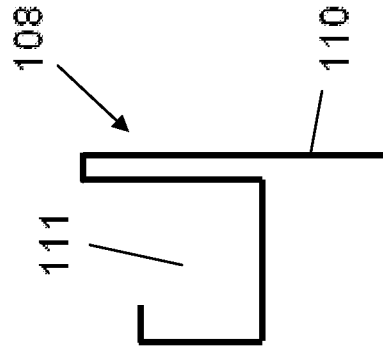

Fig. 21

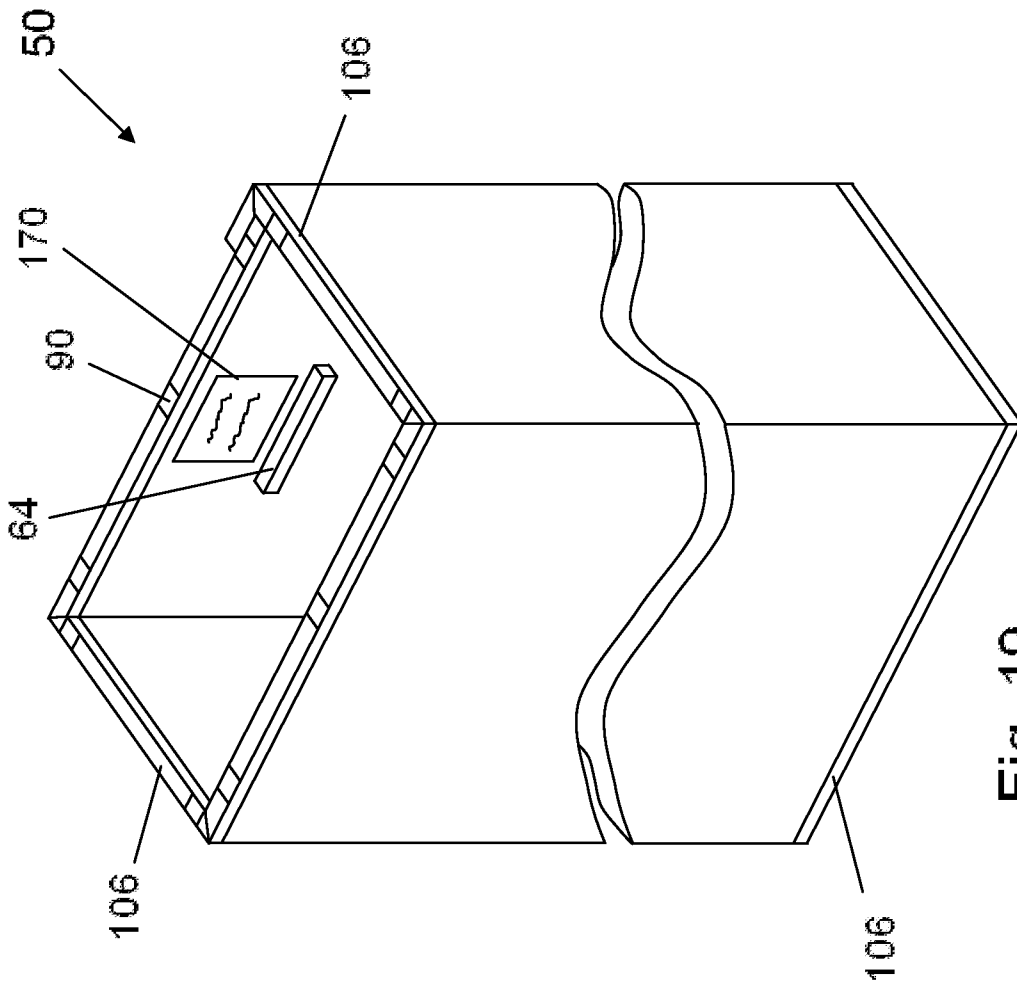

Fig. 19

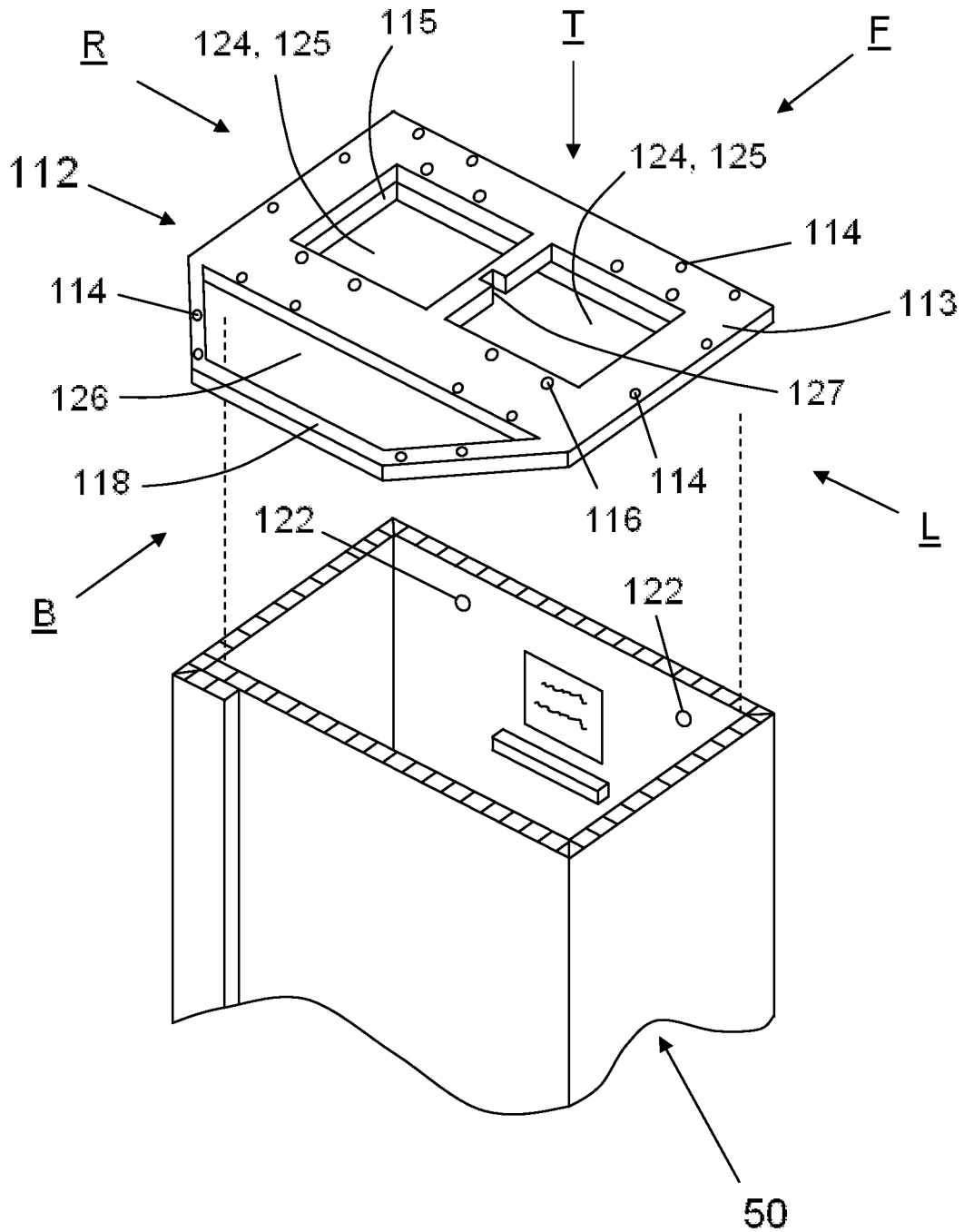

Fig. 22

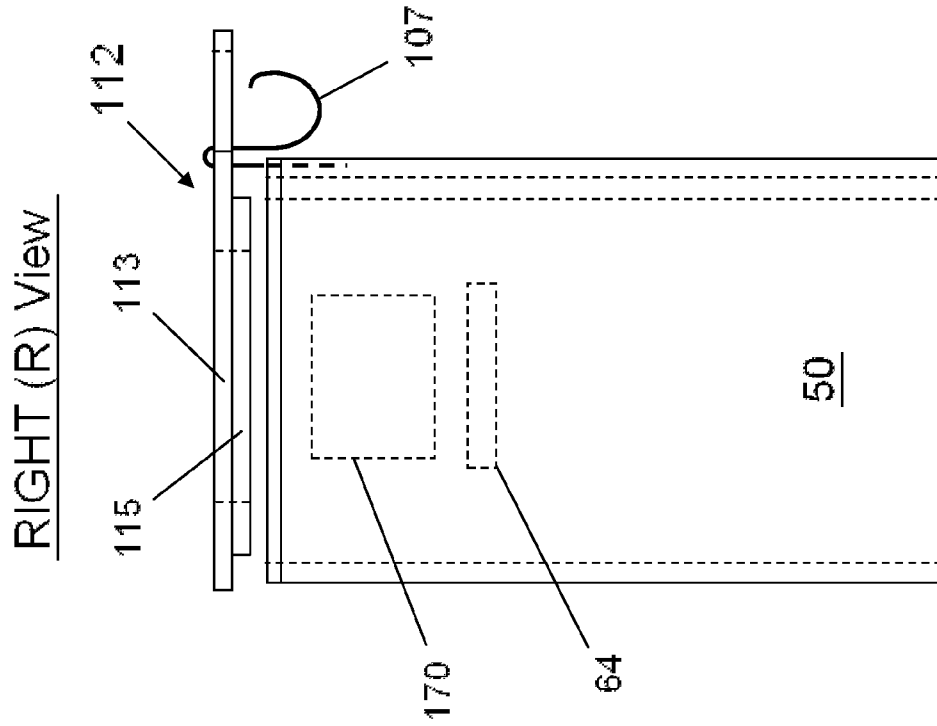

Fig. 23B

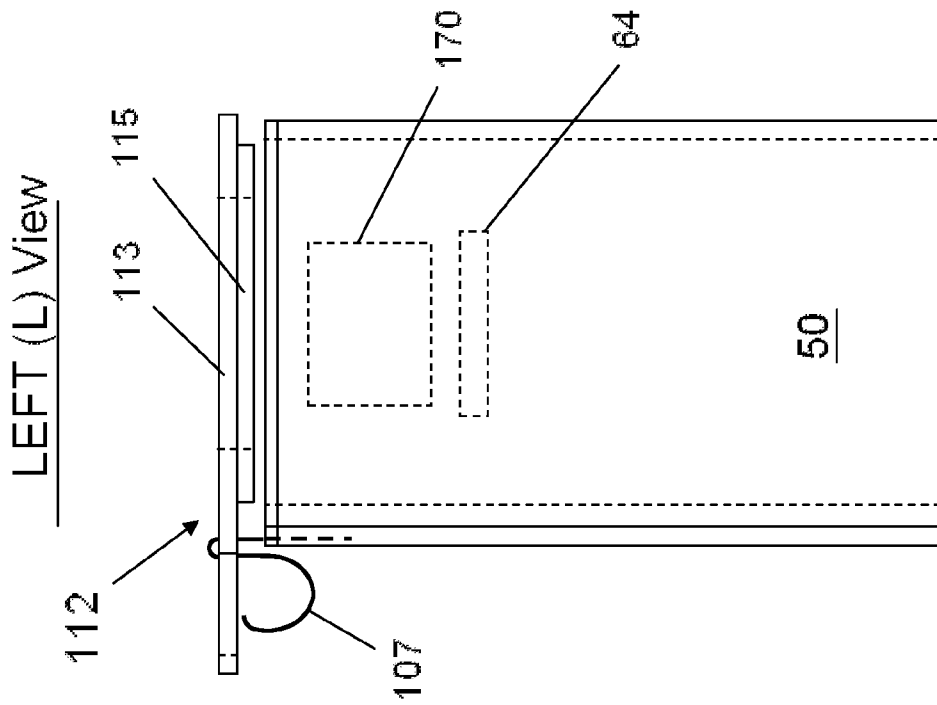

Fig. 23A

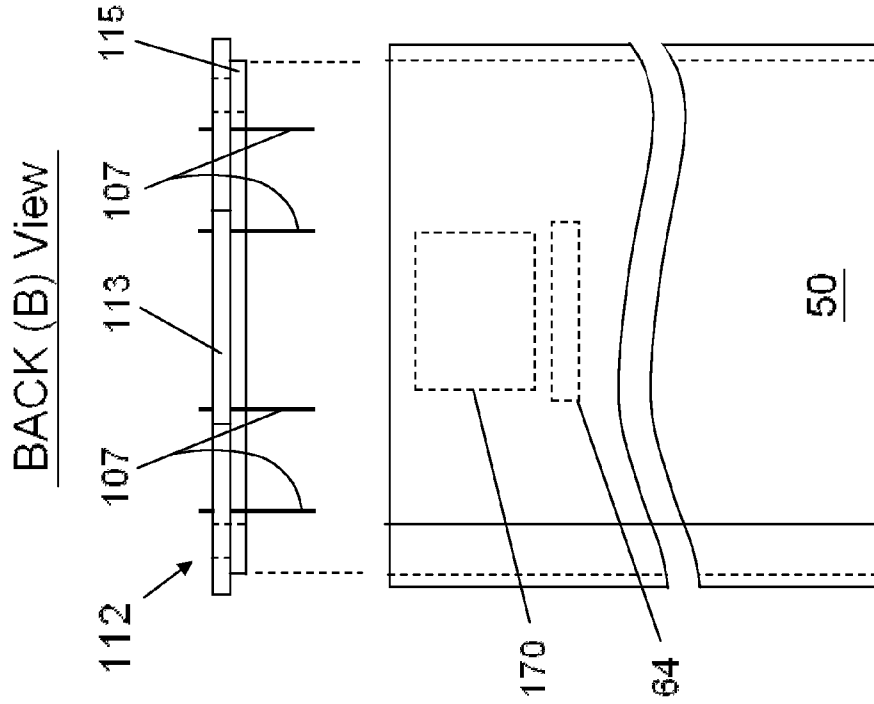

Fig. 23D

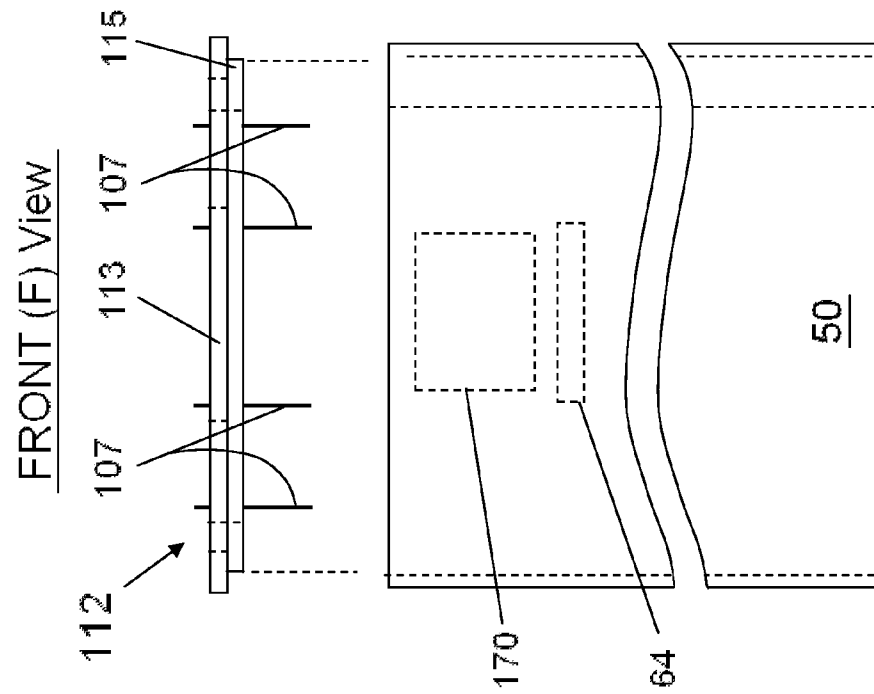

Fig. 23C

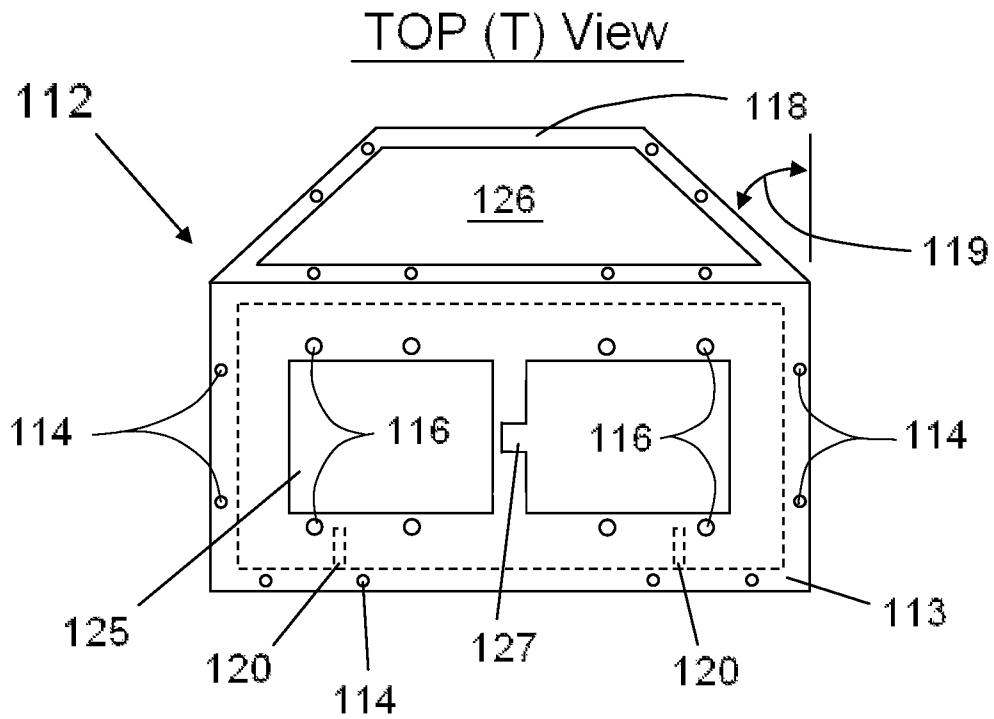

Fig. 24A

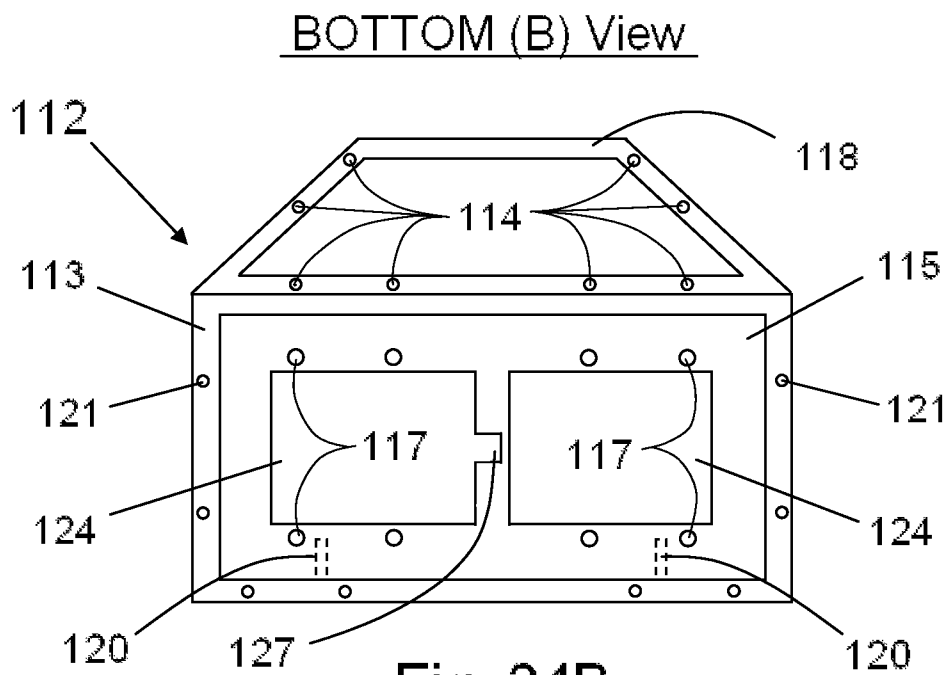

Fig. 24B

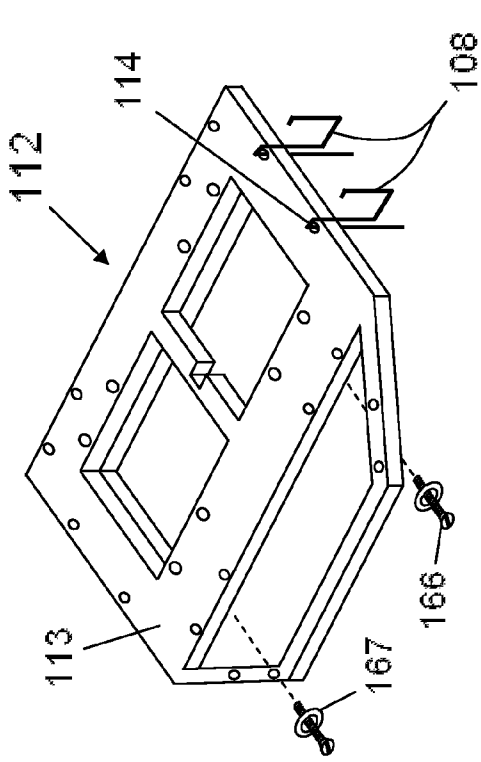

Fig. 25B

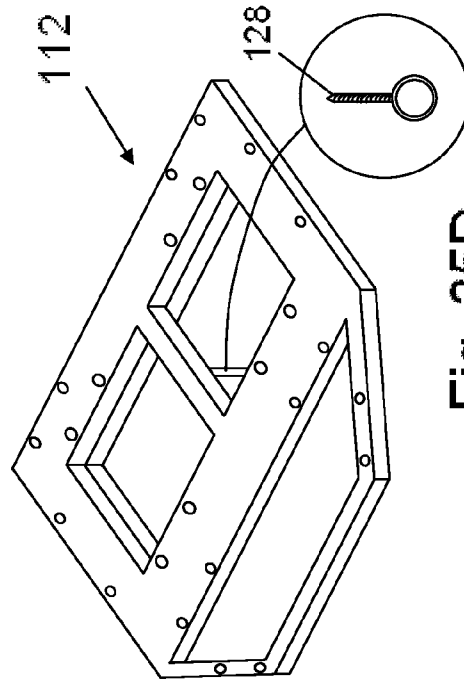

Fig. 25D

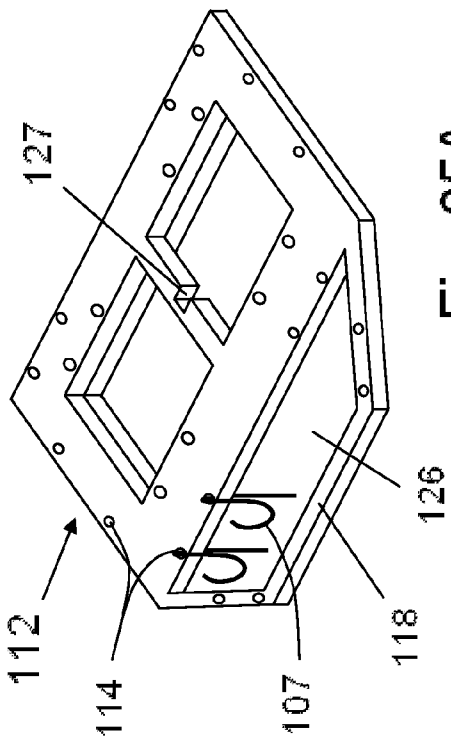

Fig. 25A

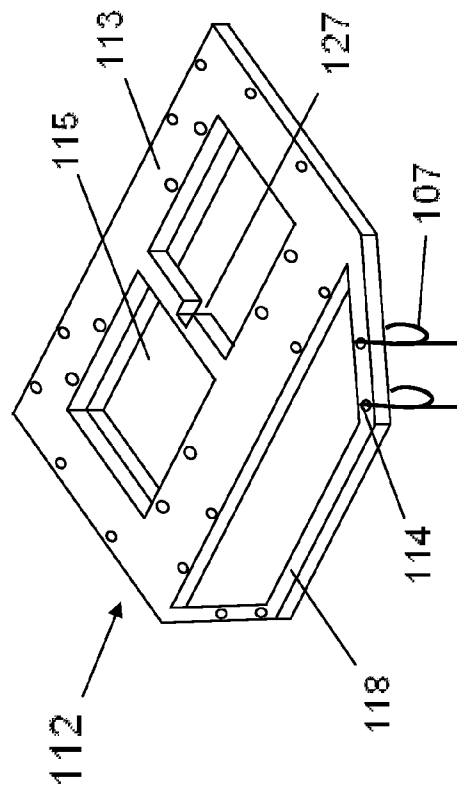

Fig. 25C

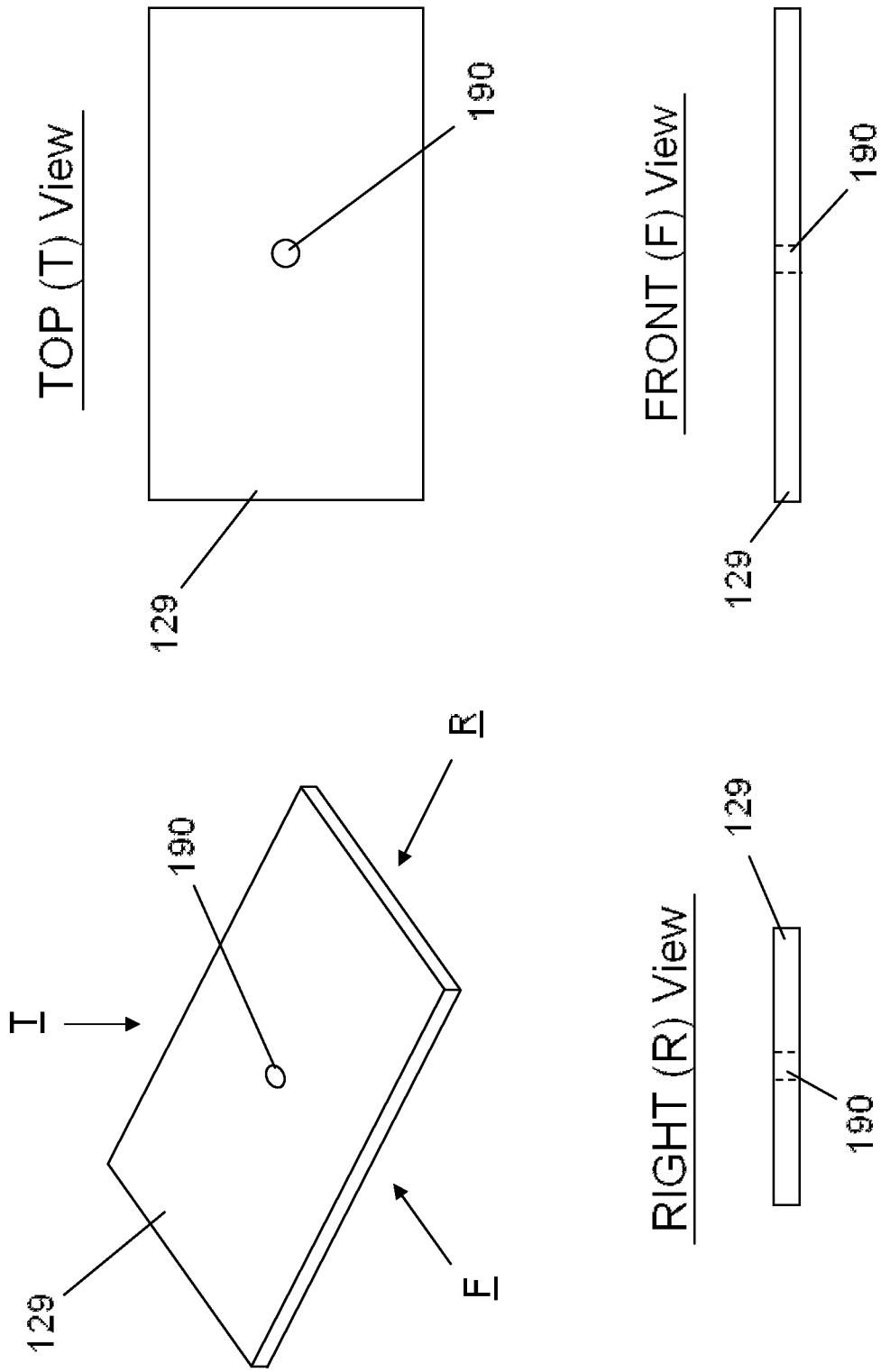

Fig. 26A

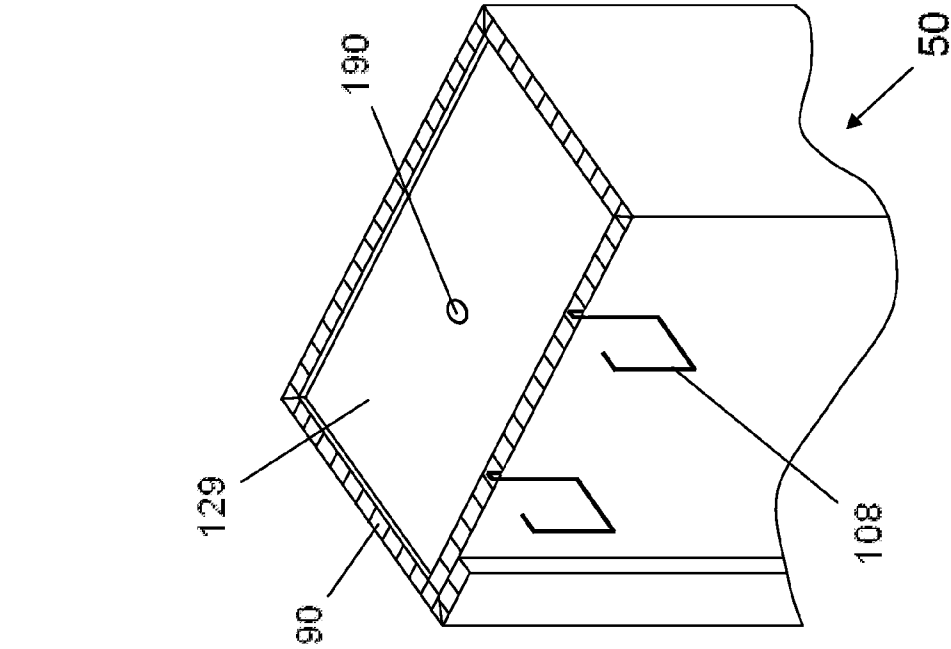

Fig. 26C

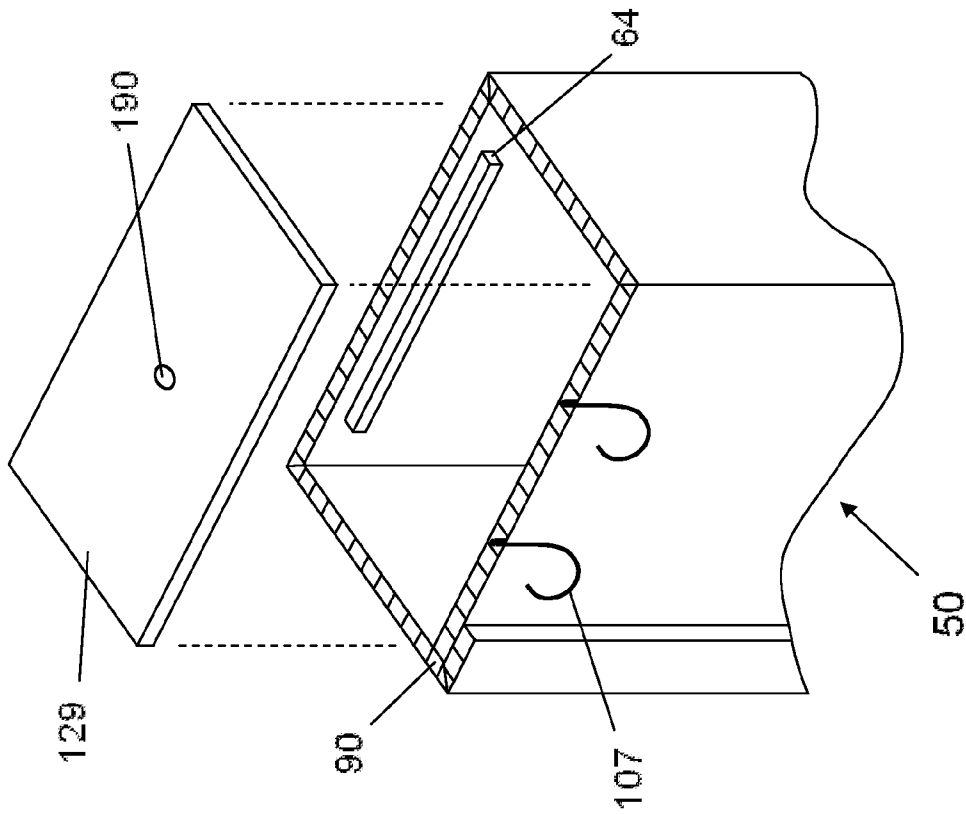

Fig. 26B

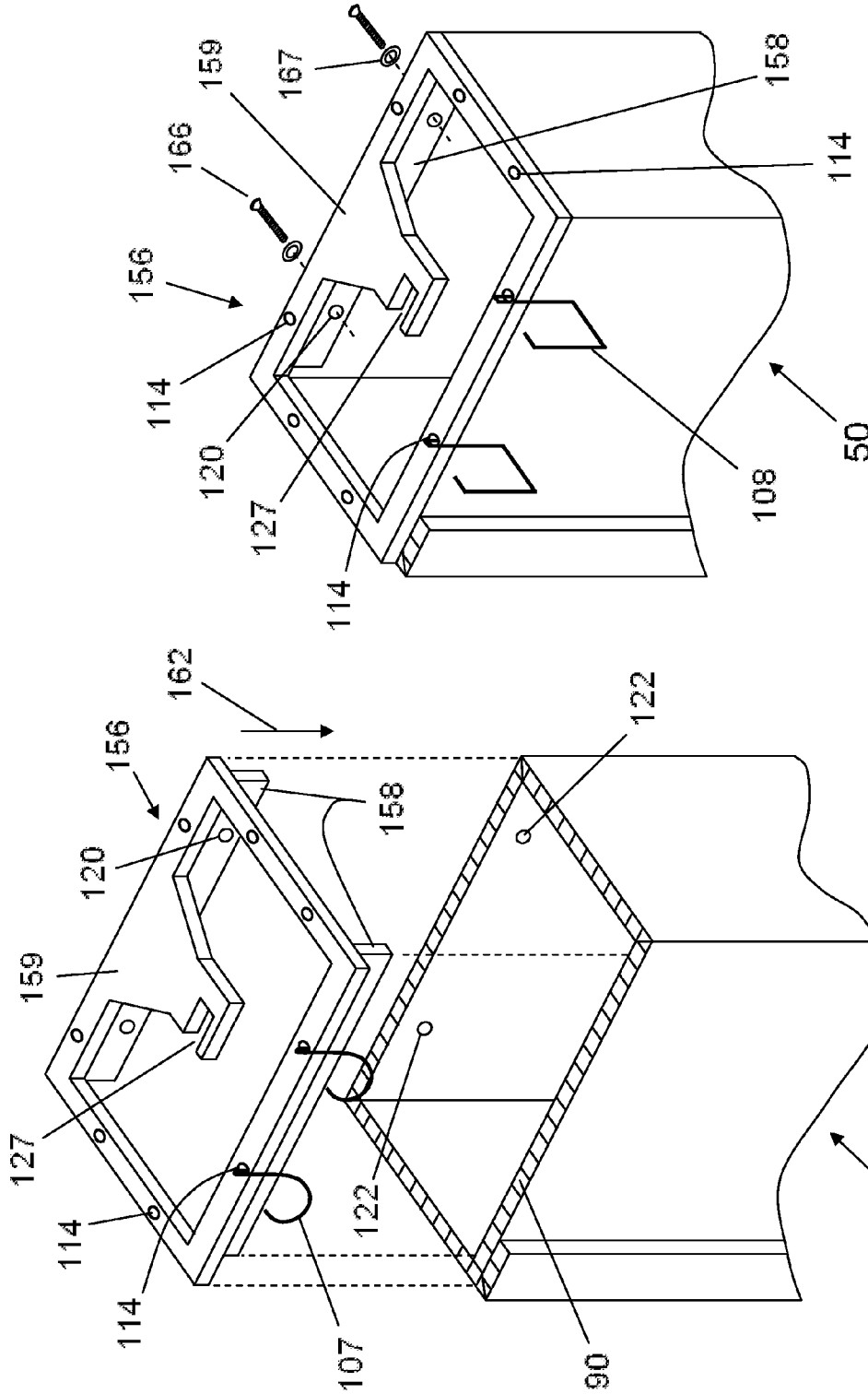

Fig. 26E

Fig. 26D

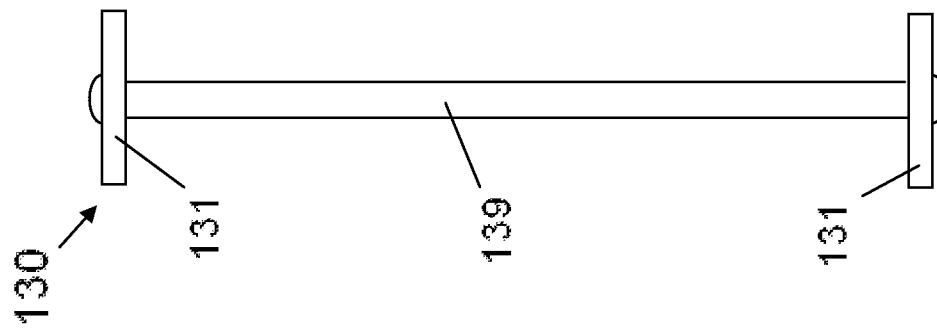

Fig. 27A

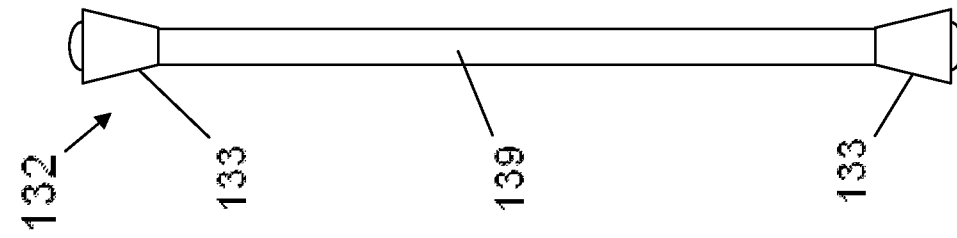

Fig. 27B

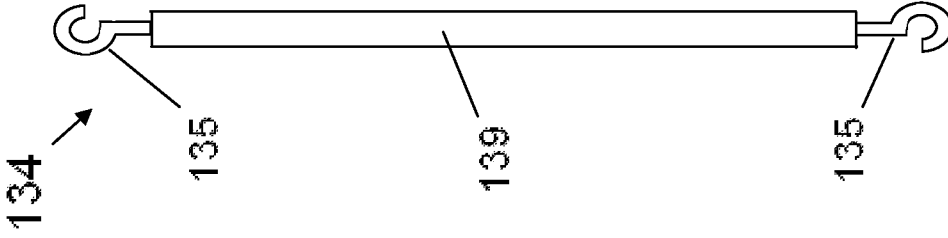

Fig. 27C

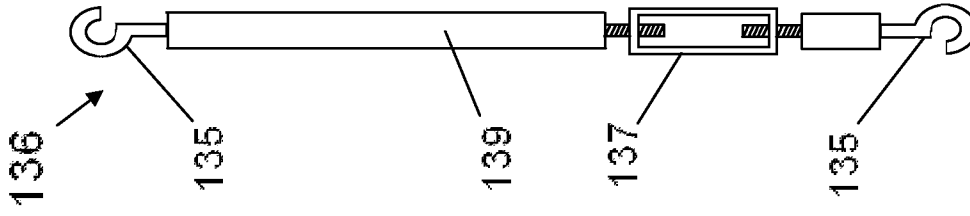
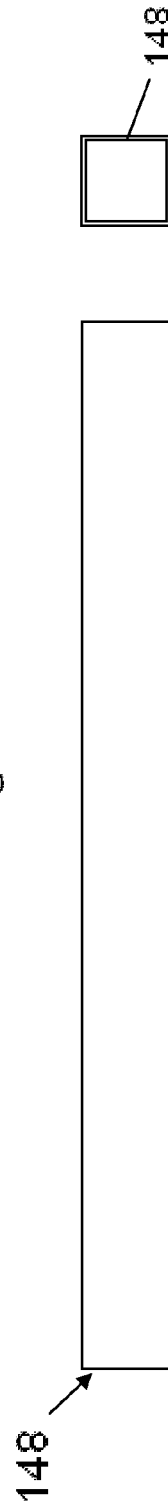
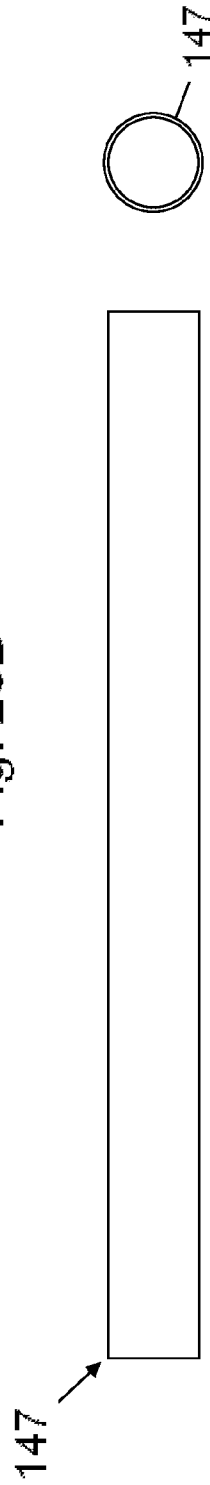
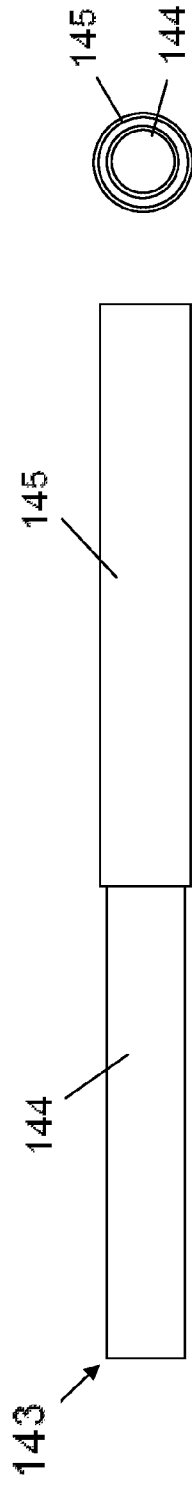
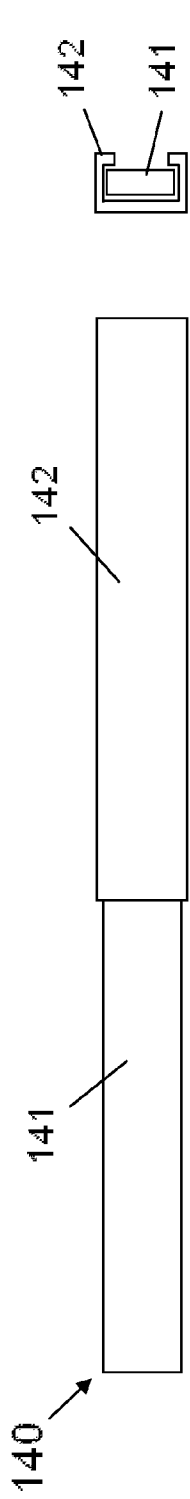

Fig. 27D



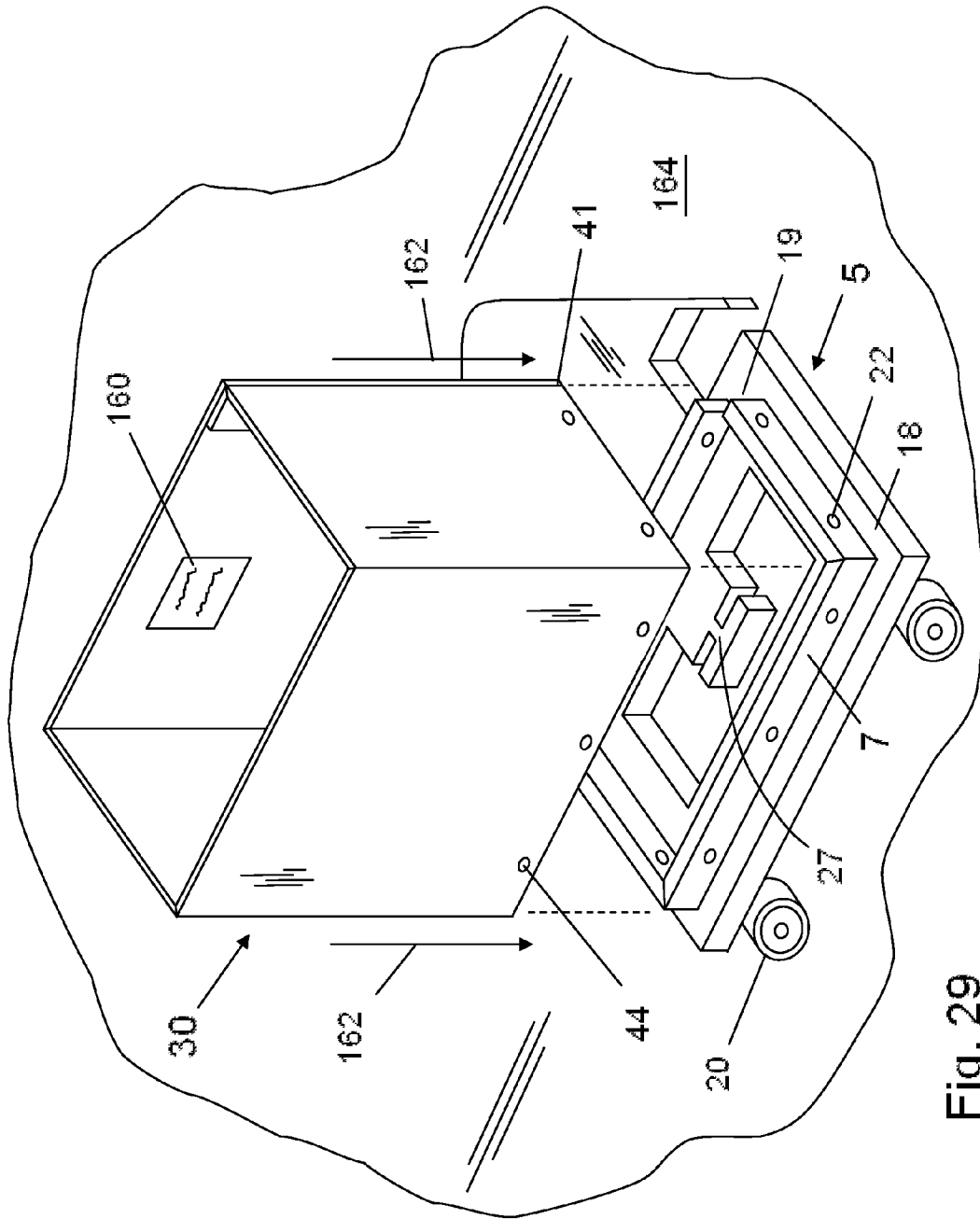

Fig. 29

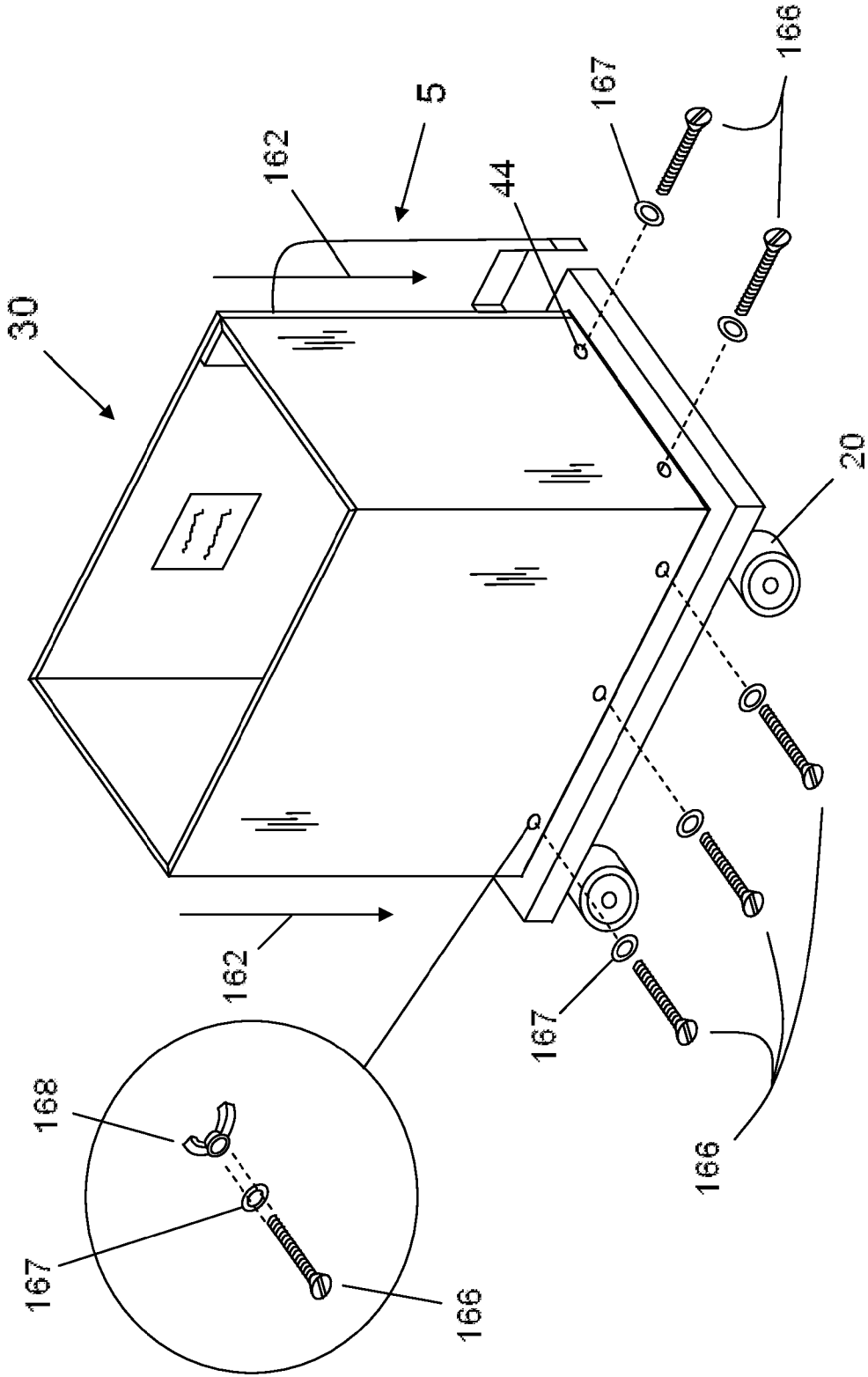

Fig. 30

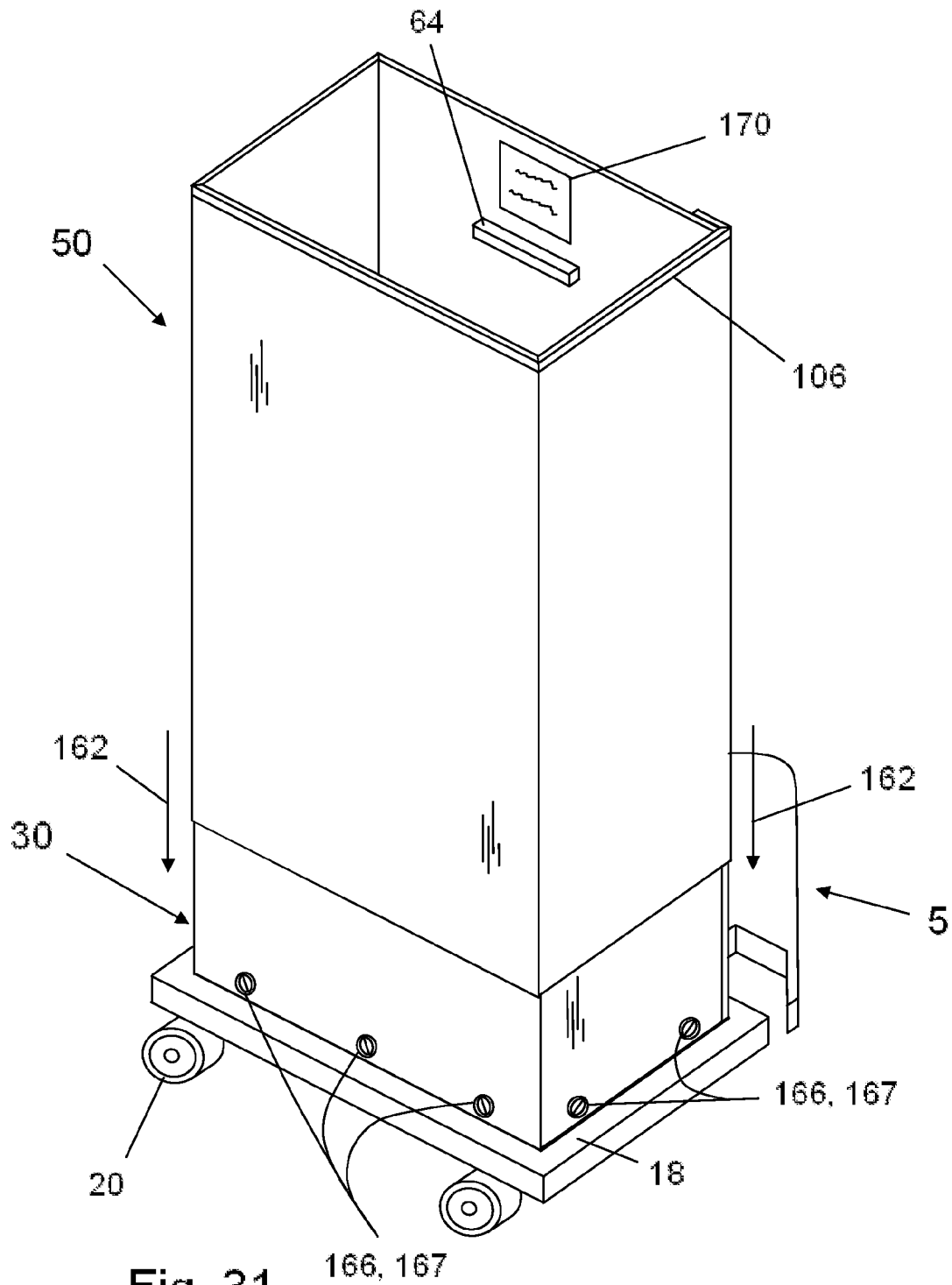

Fig. 31

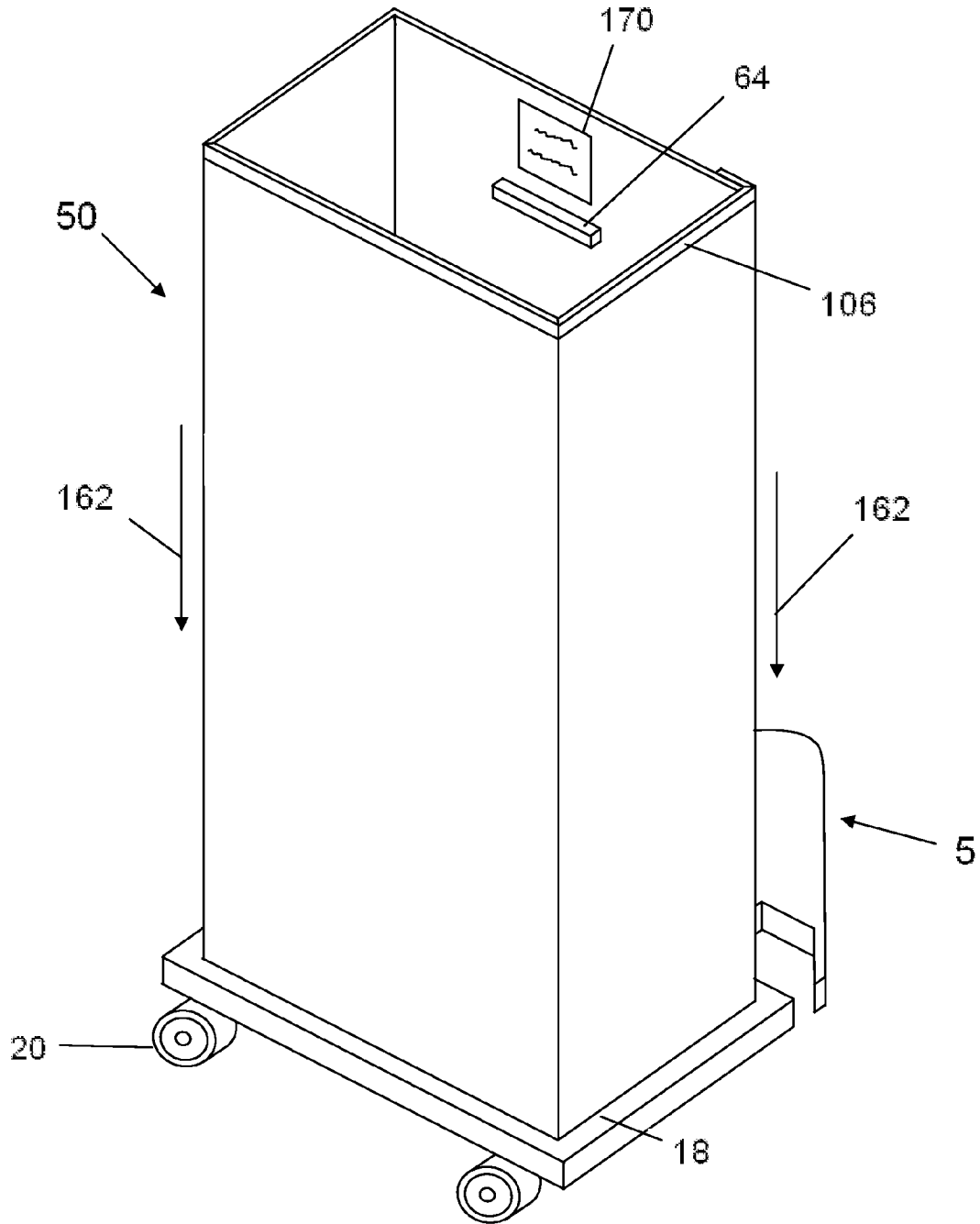

Fig. 32

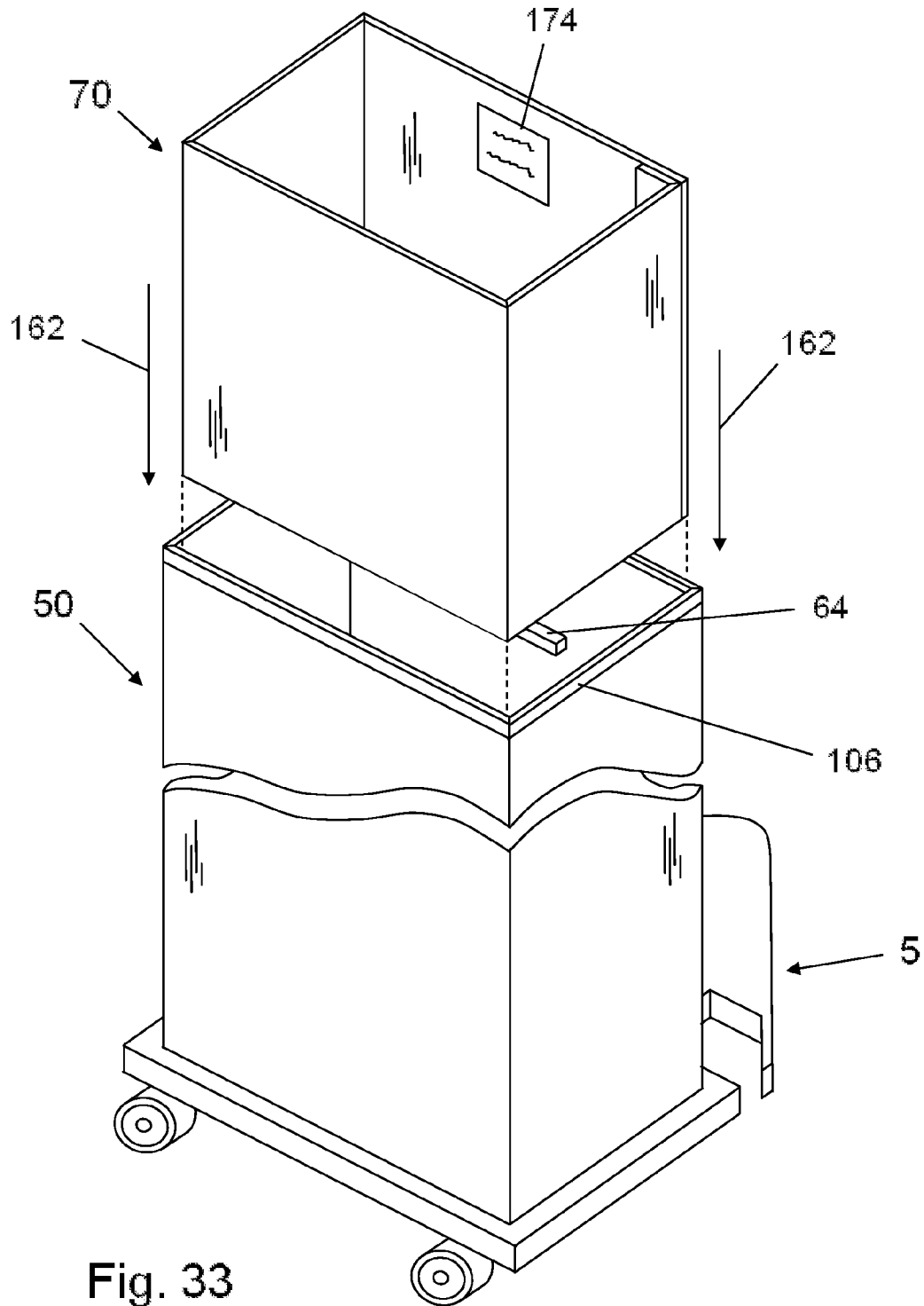

Fig. 33

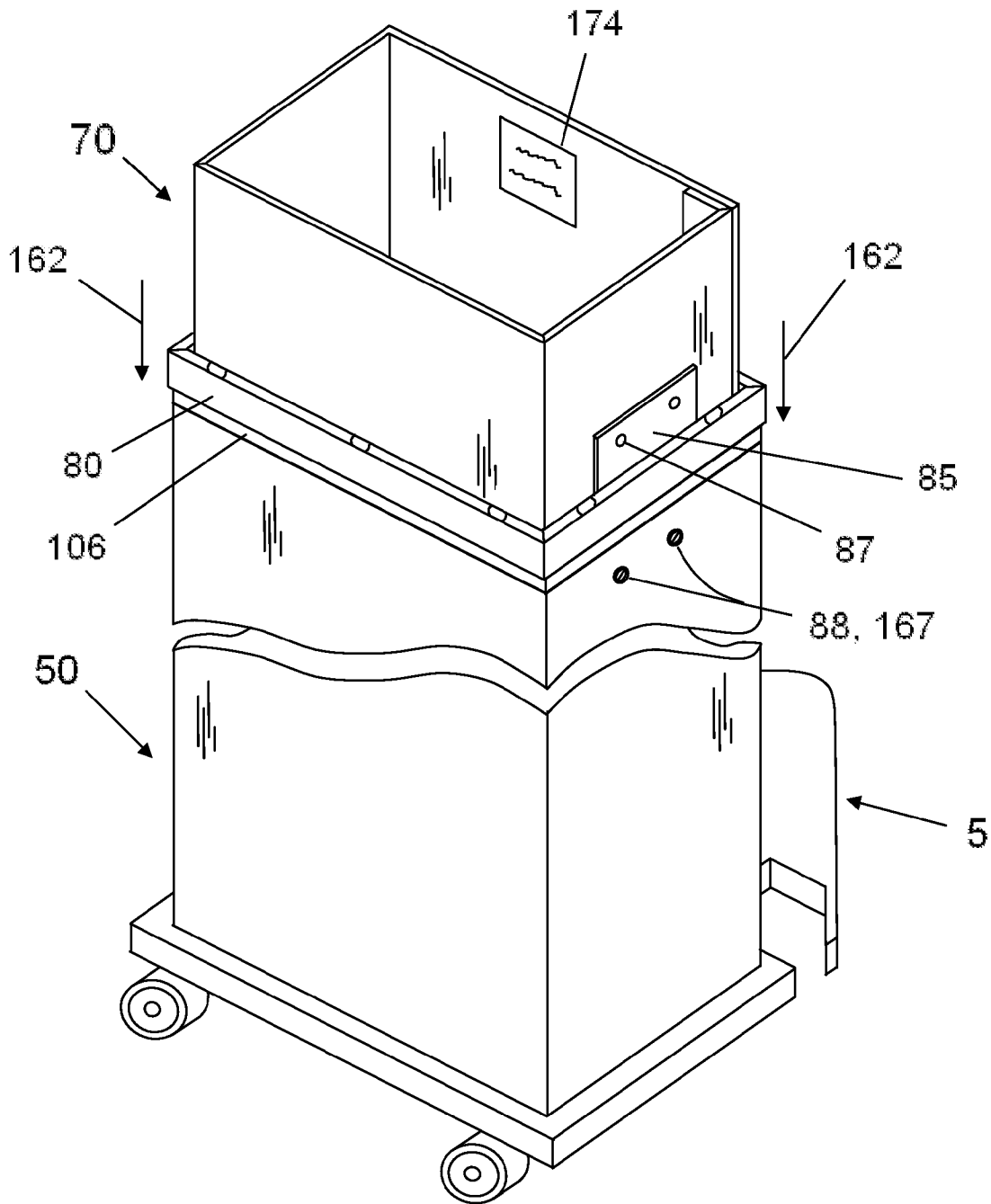

Fig. 34

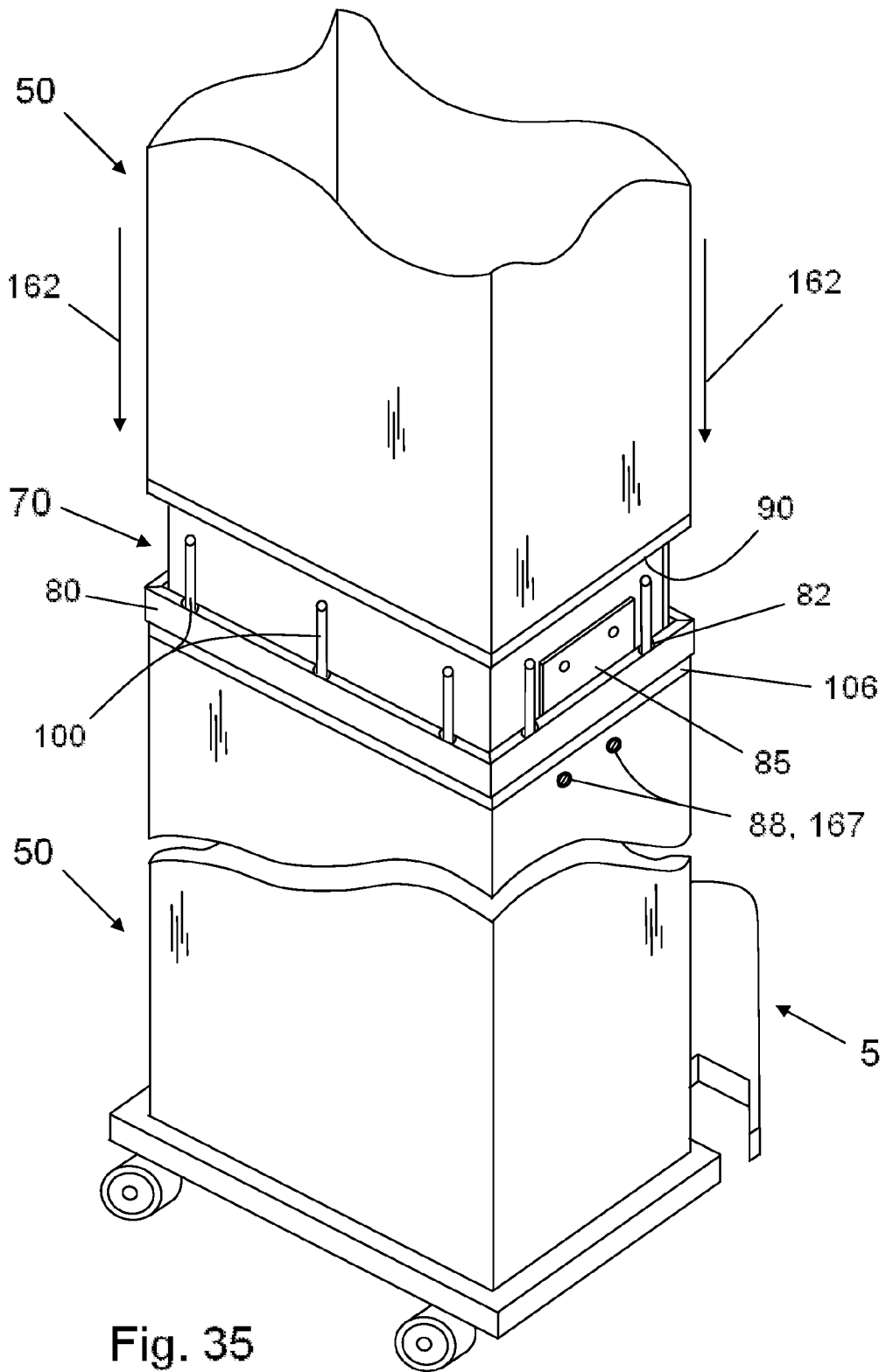

Fig. 35

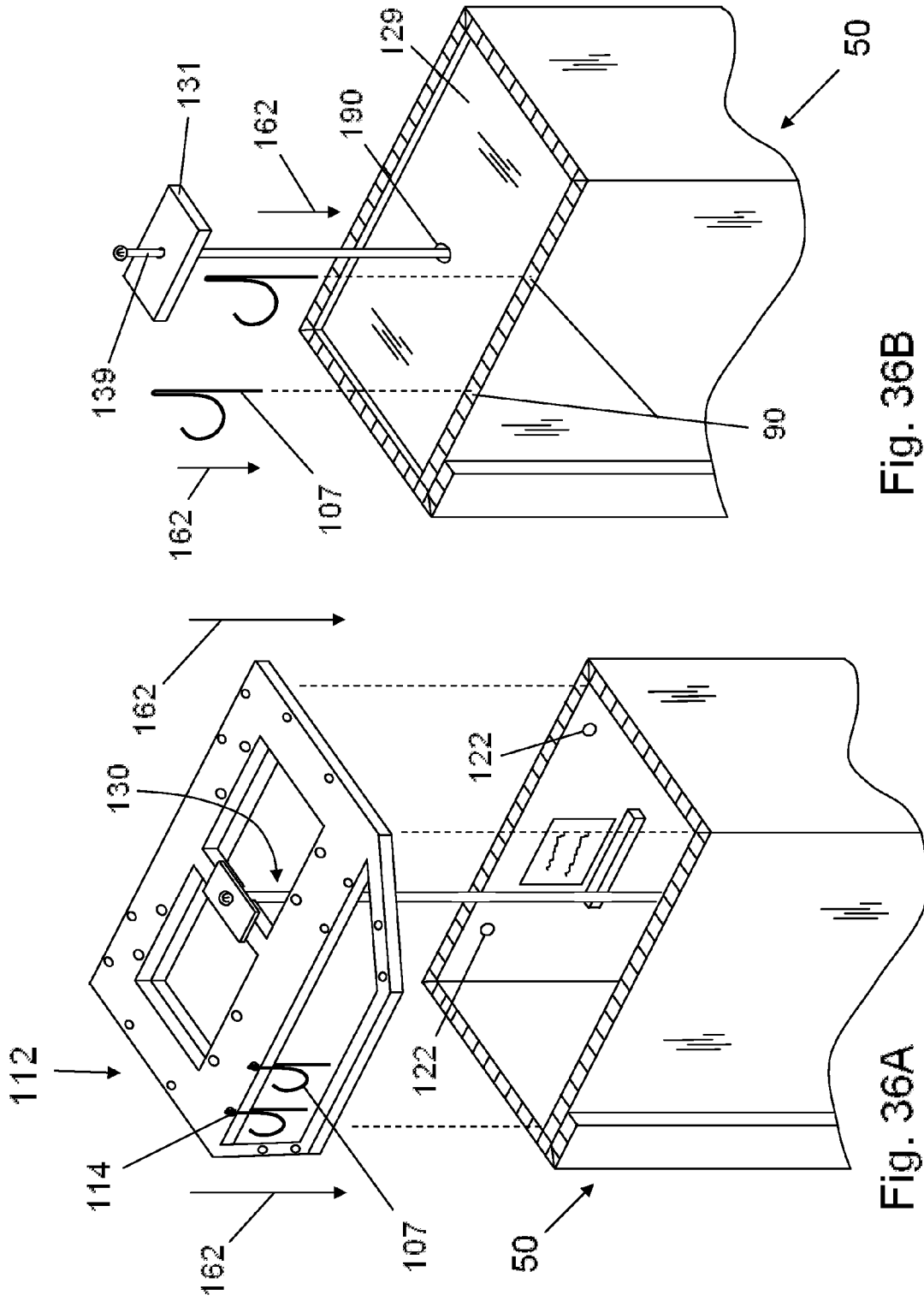

Fig. 36B

Fig. 36A

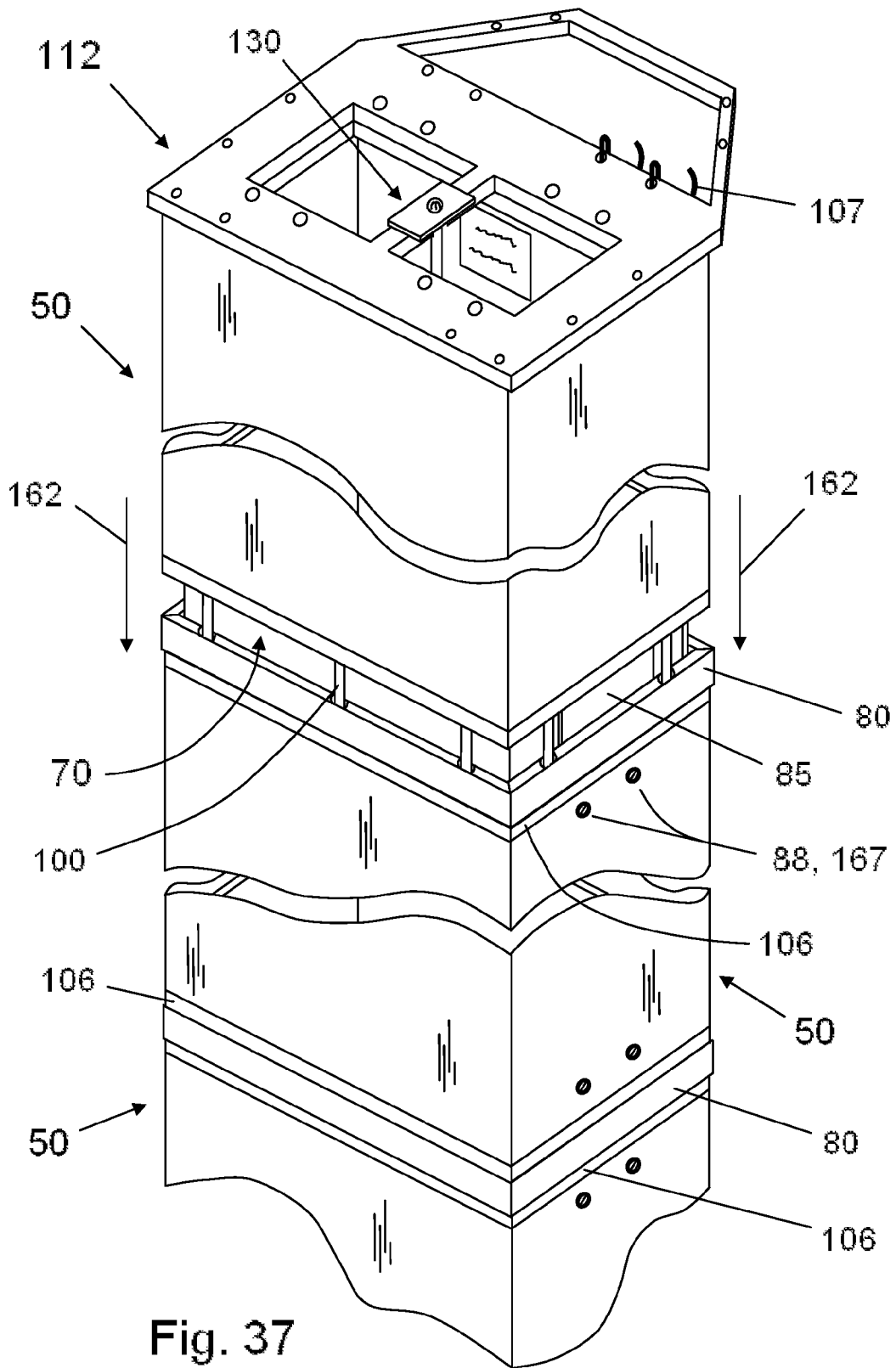

Fig. 37

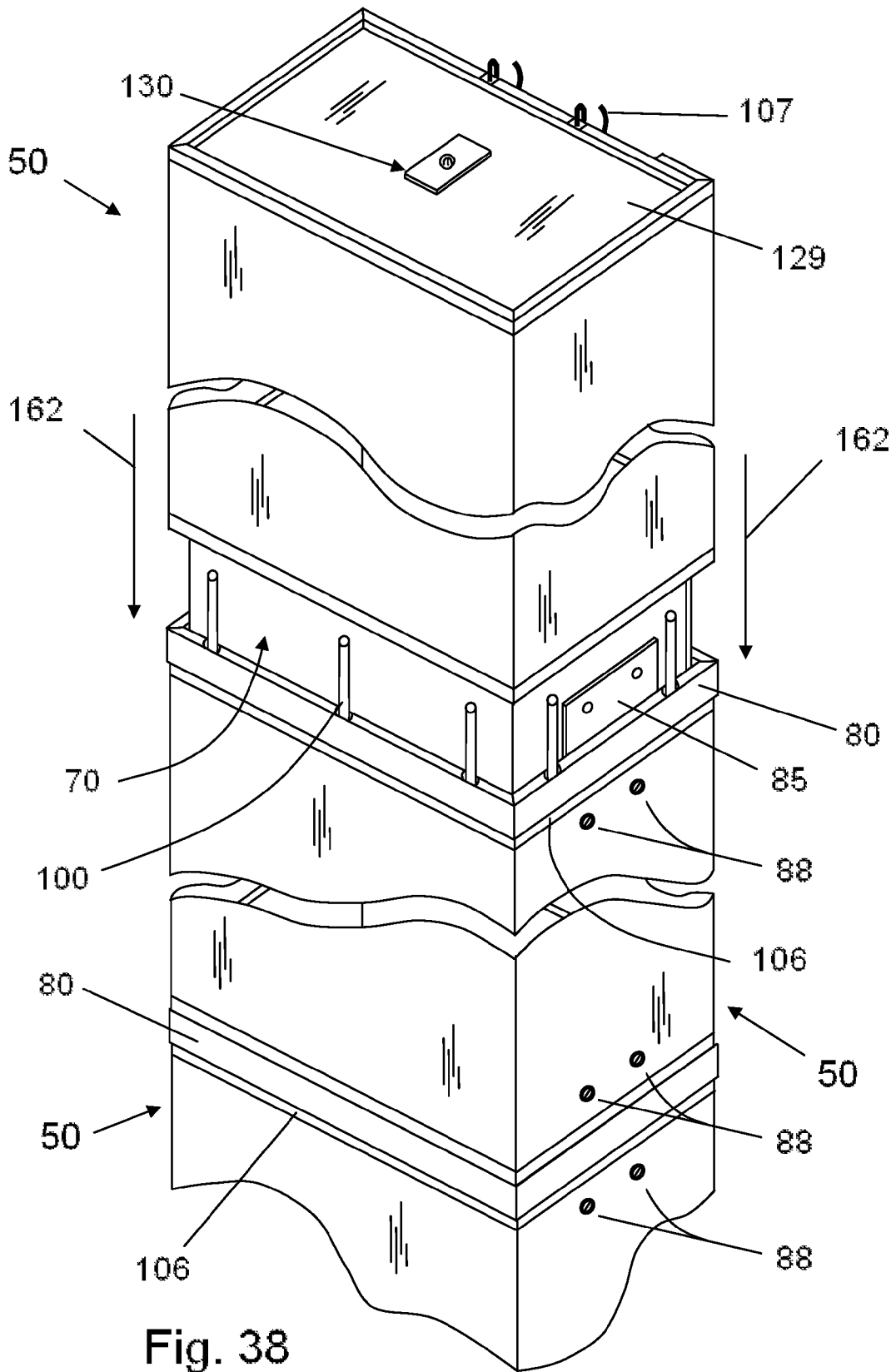

Fig. 38

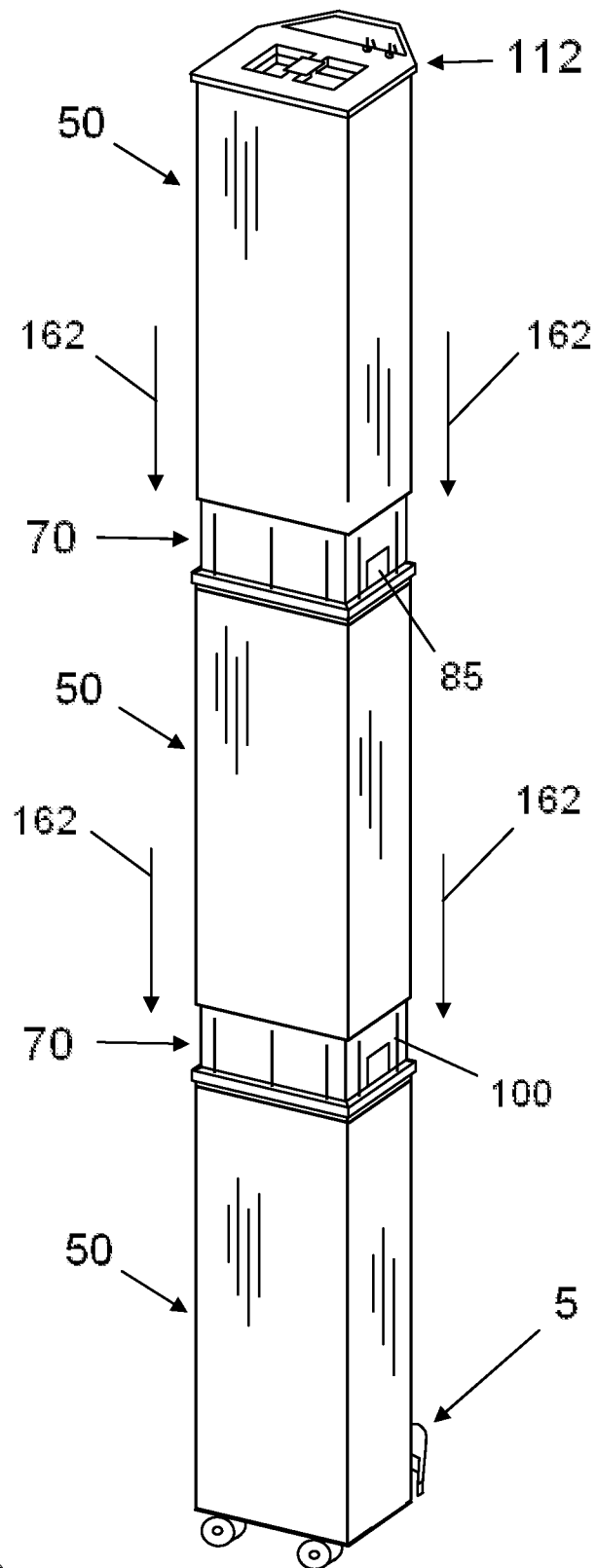

Fig. 39

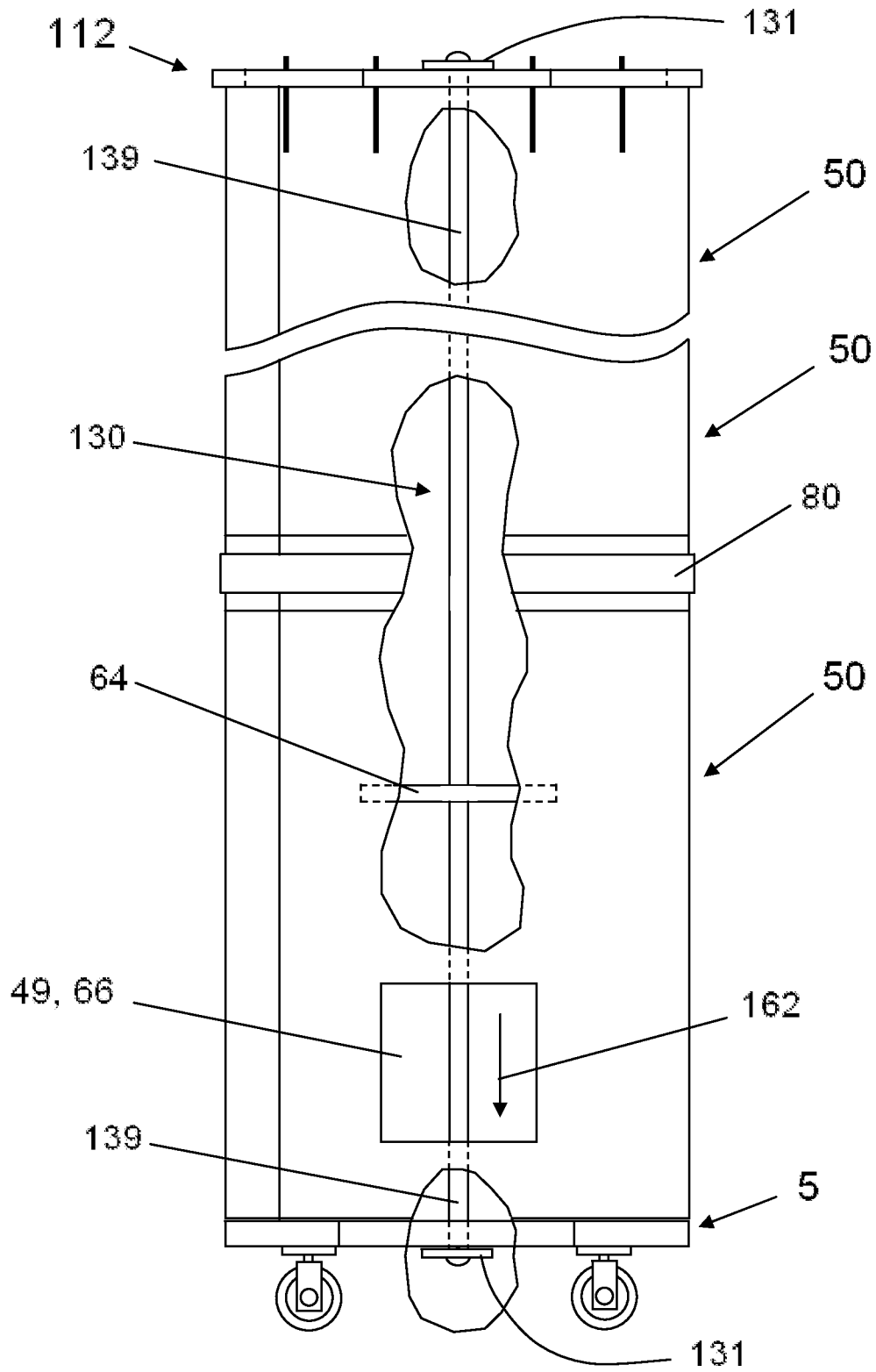

Fig. 40

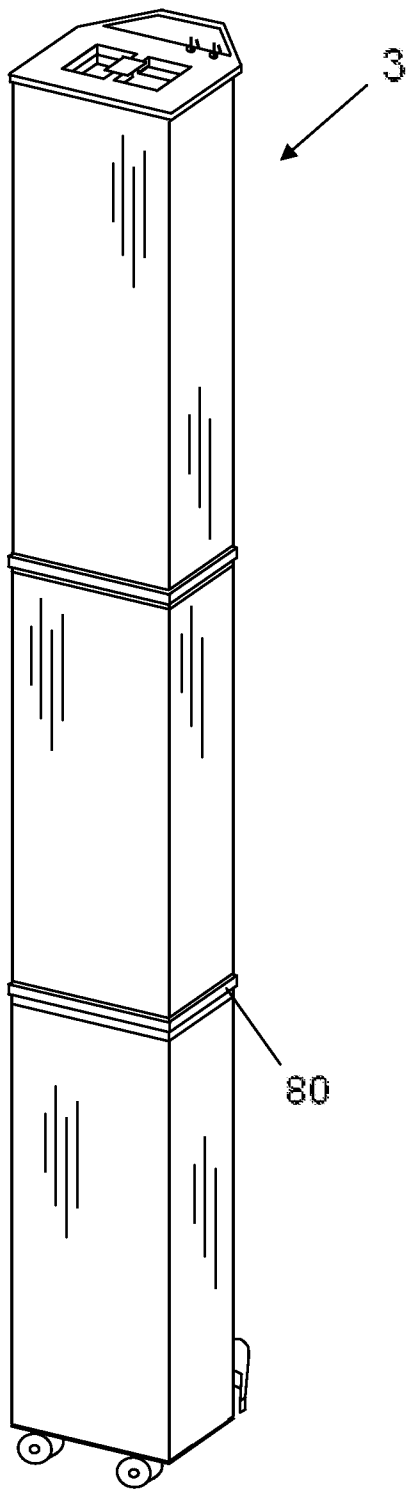

Fig. 41A

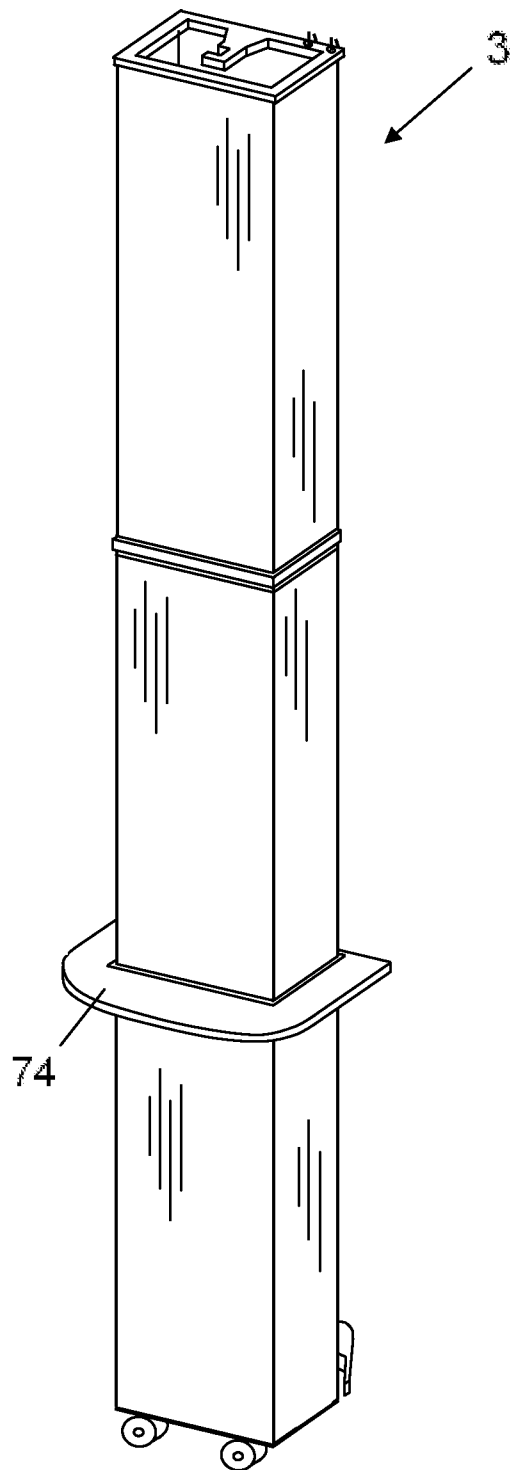

Fig. 41B

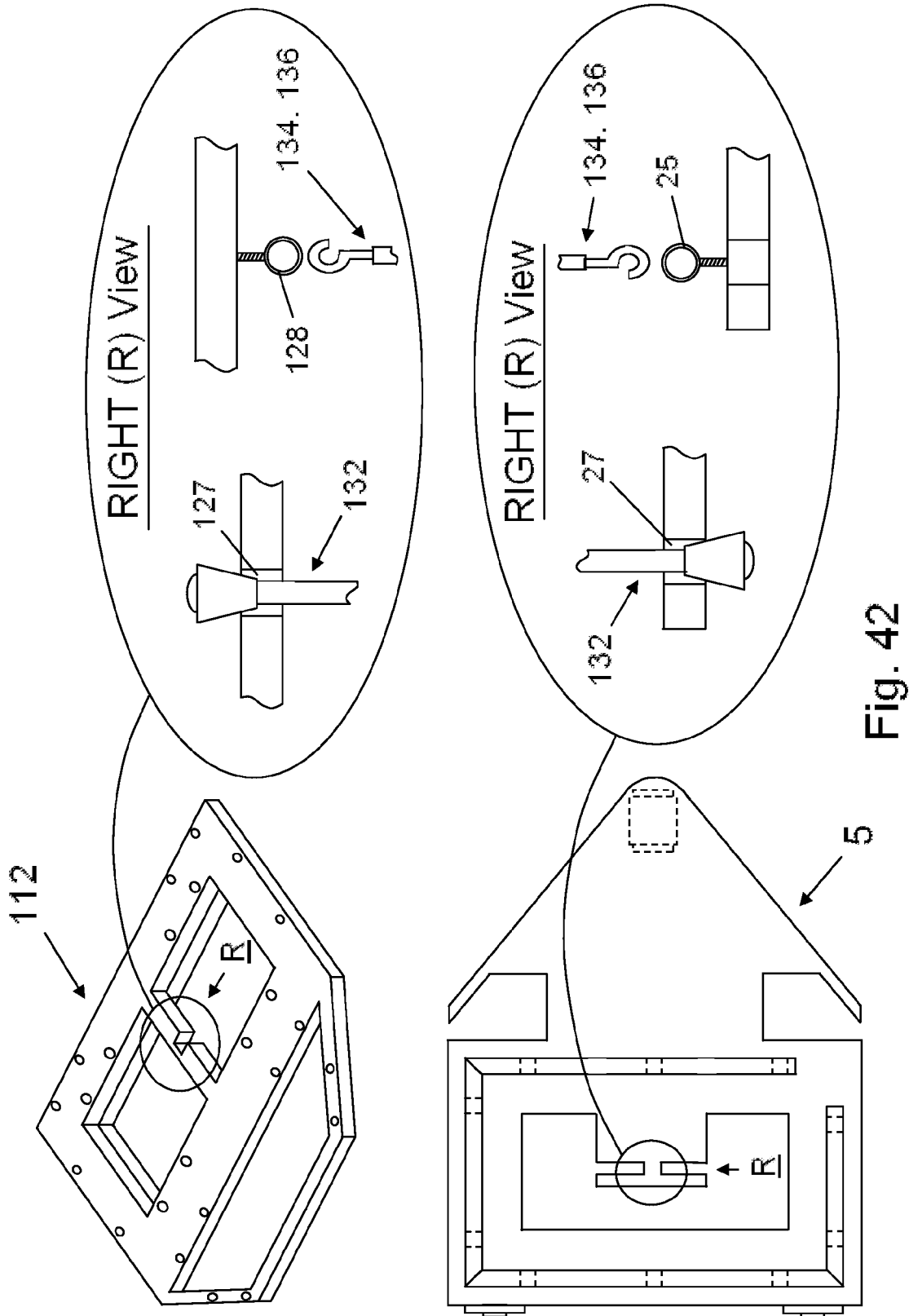

Fig. 42

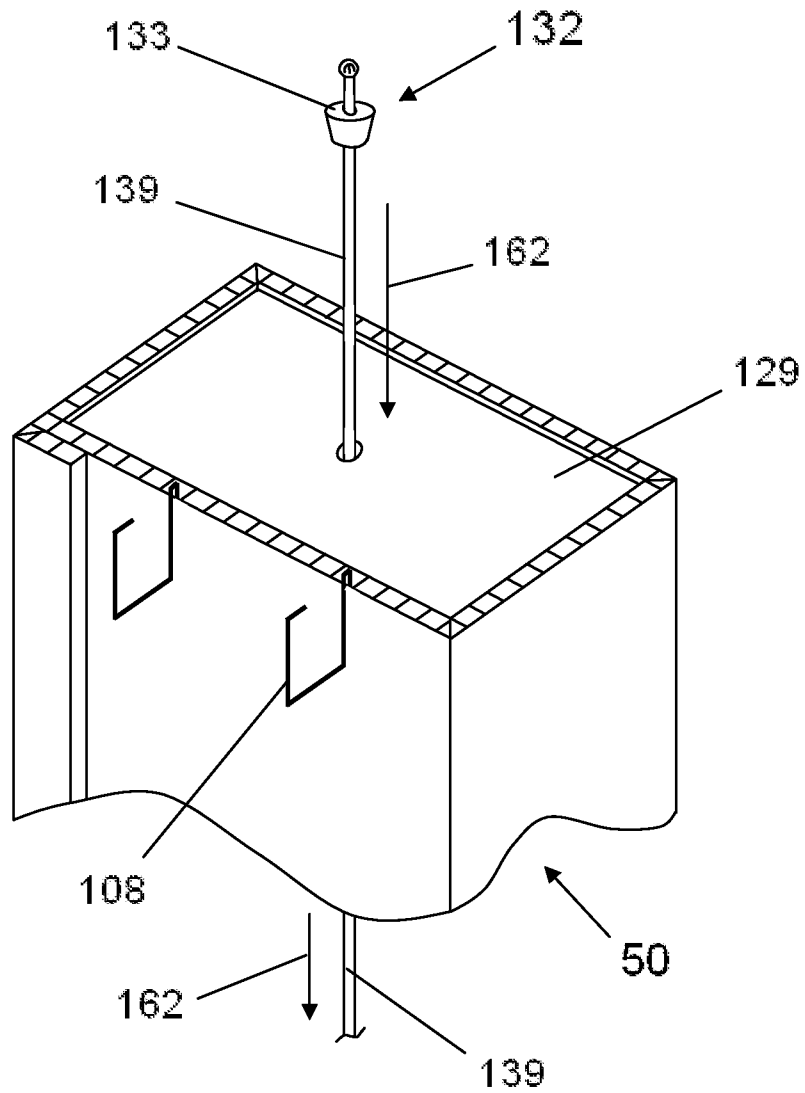

Fig. 43

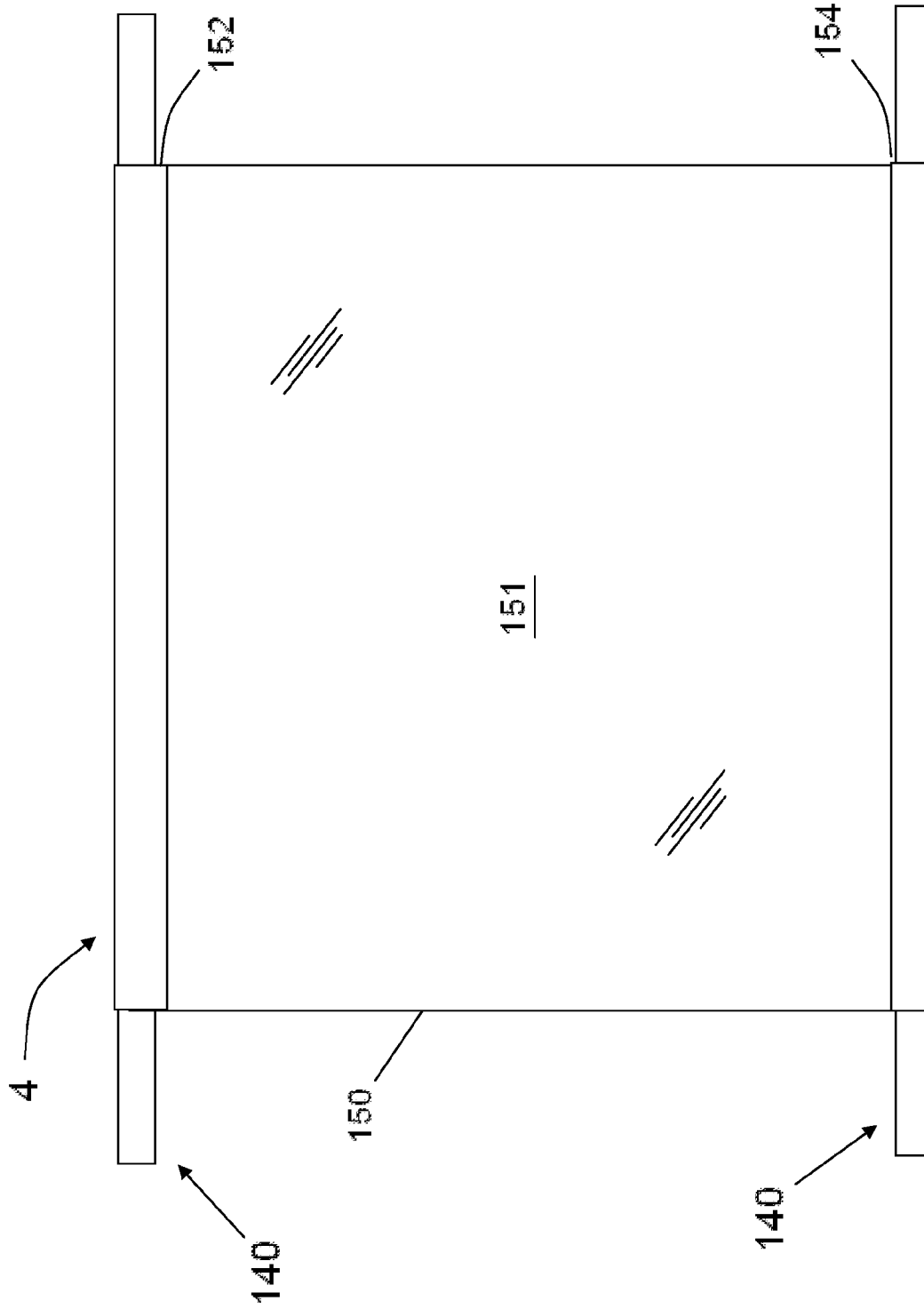

Fig. 44

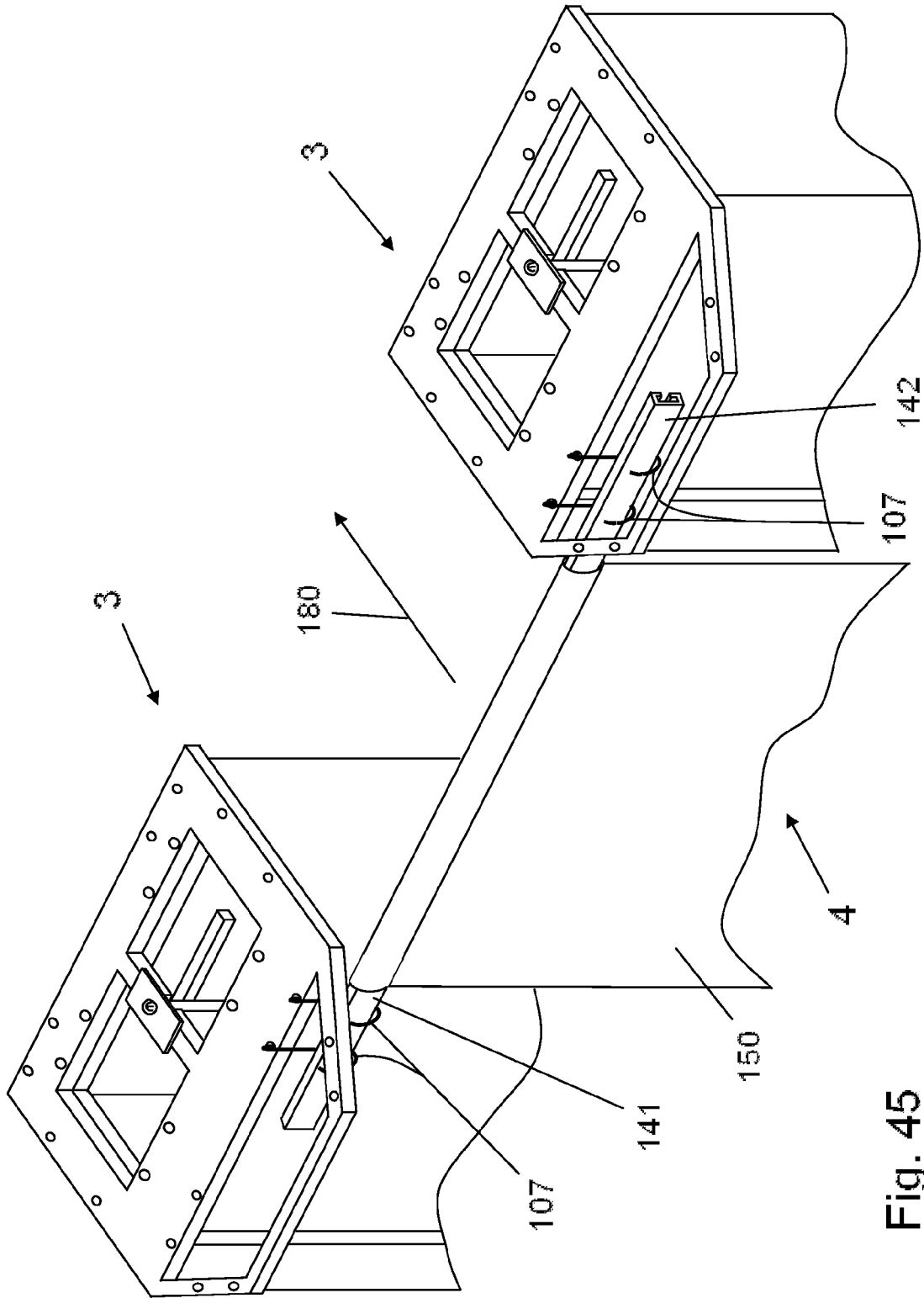

Fig. 45

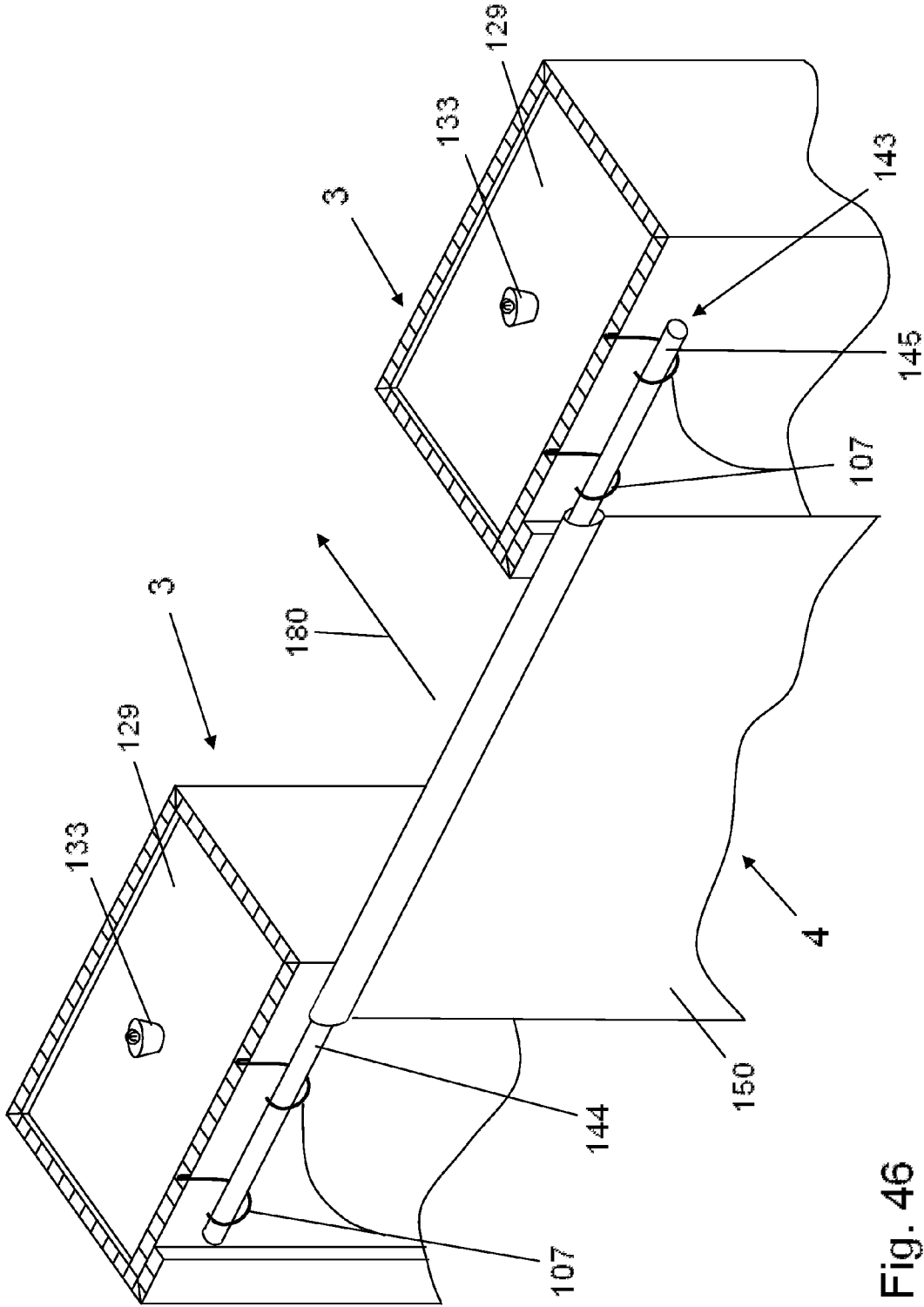

Fig. 46

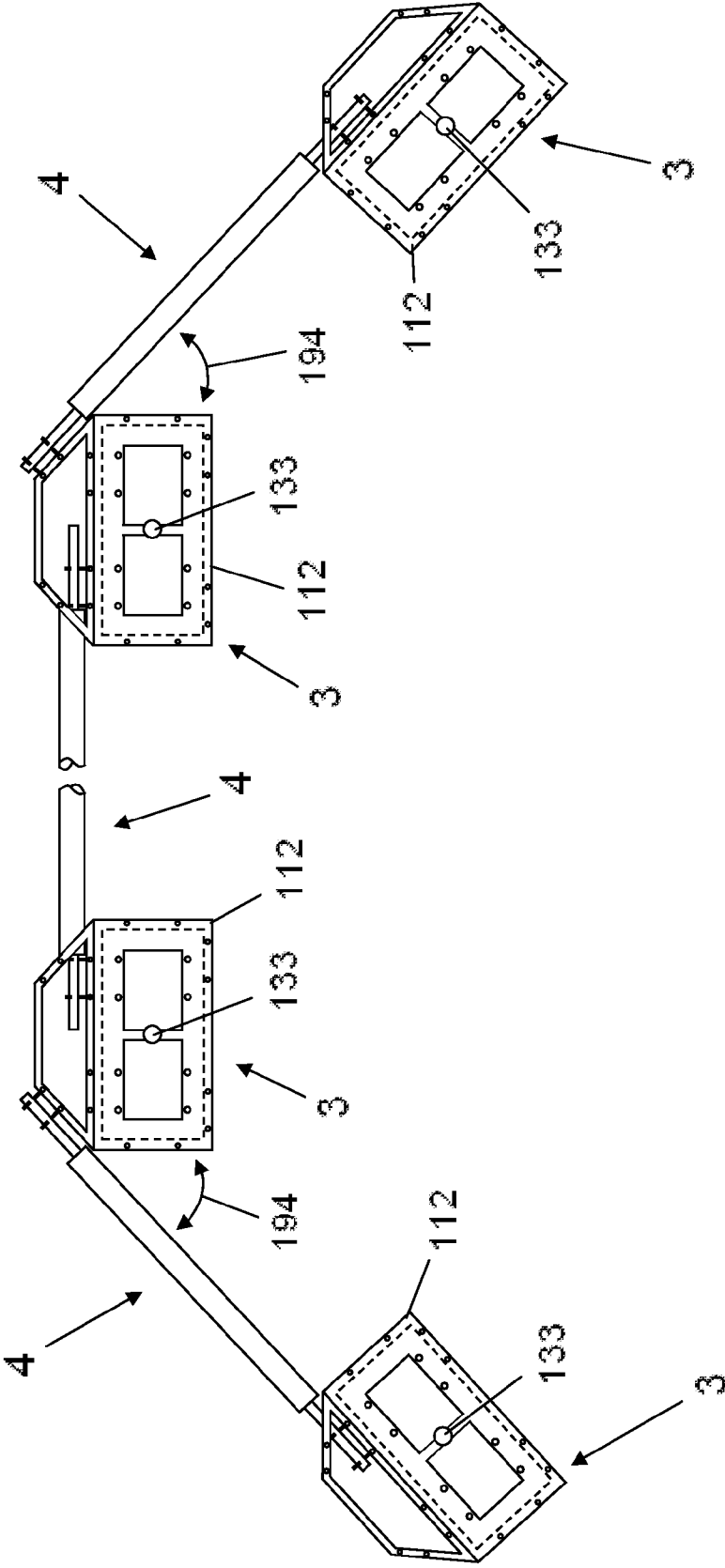

Fig. 47

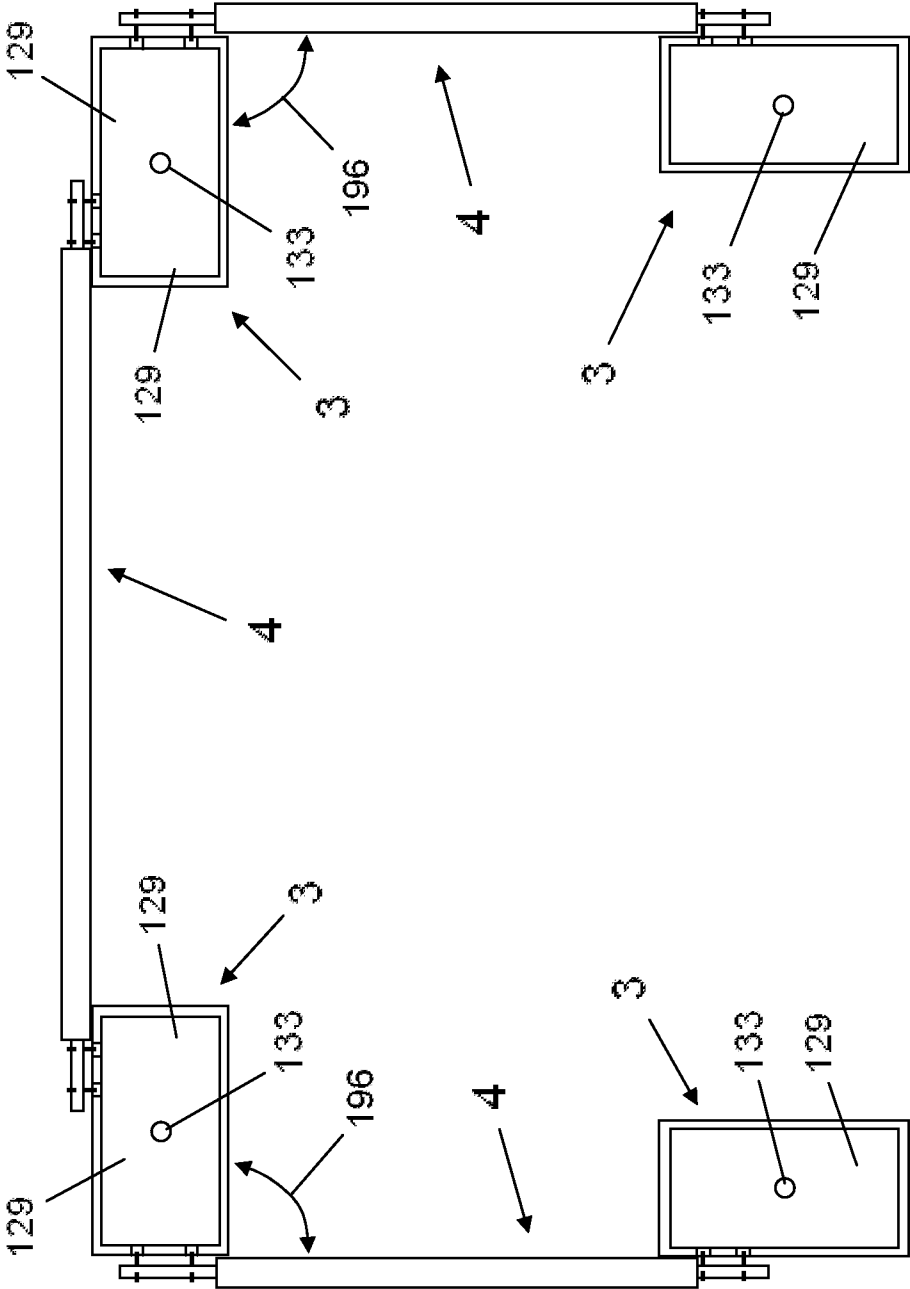

Fig. 48

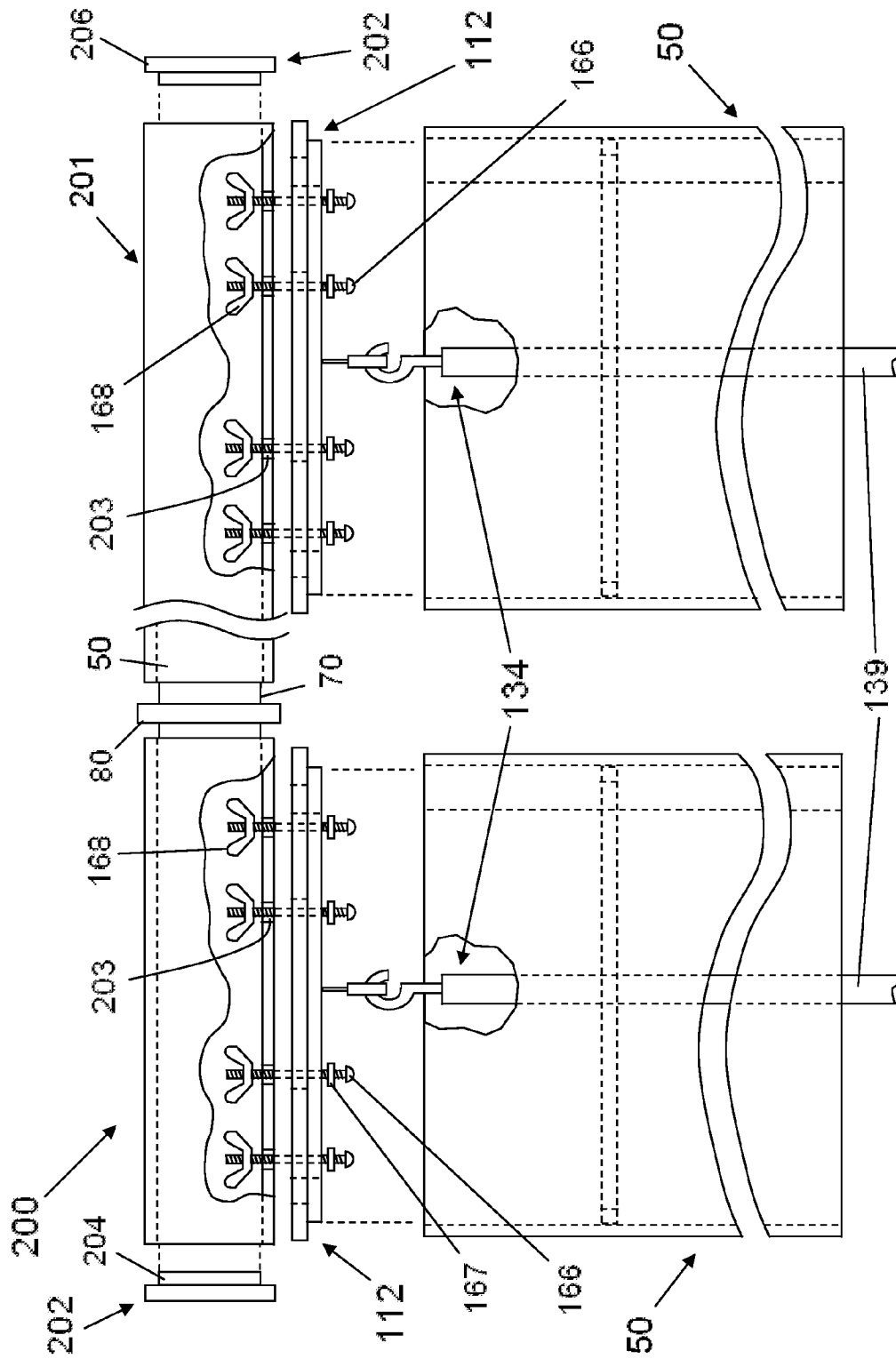

Fig. 49

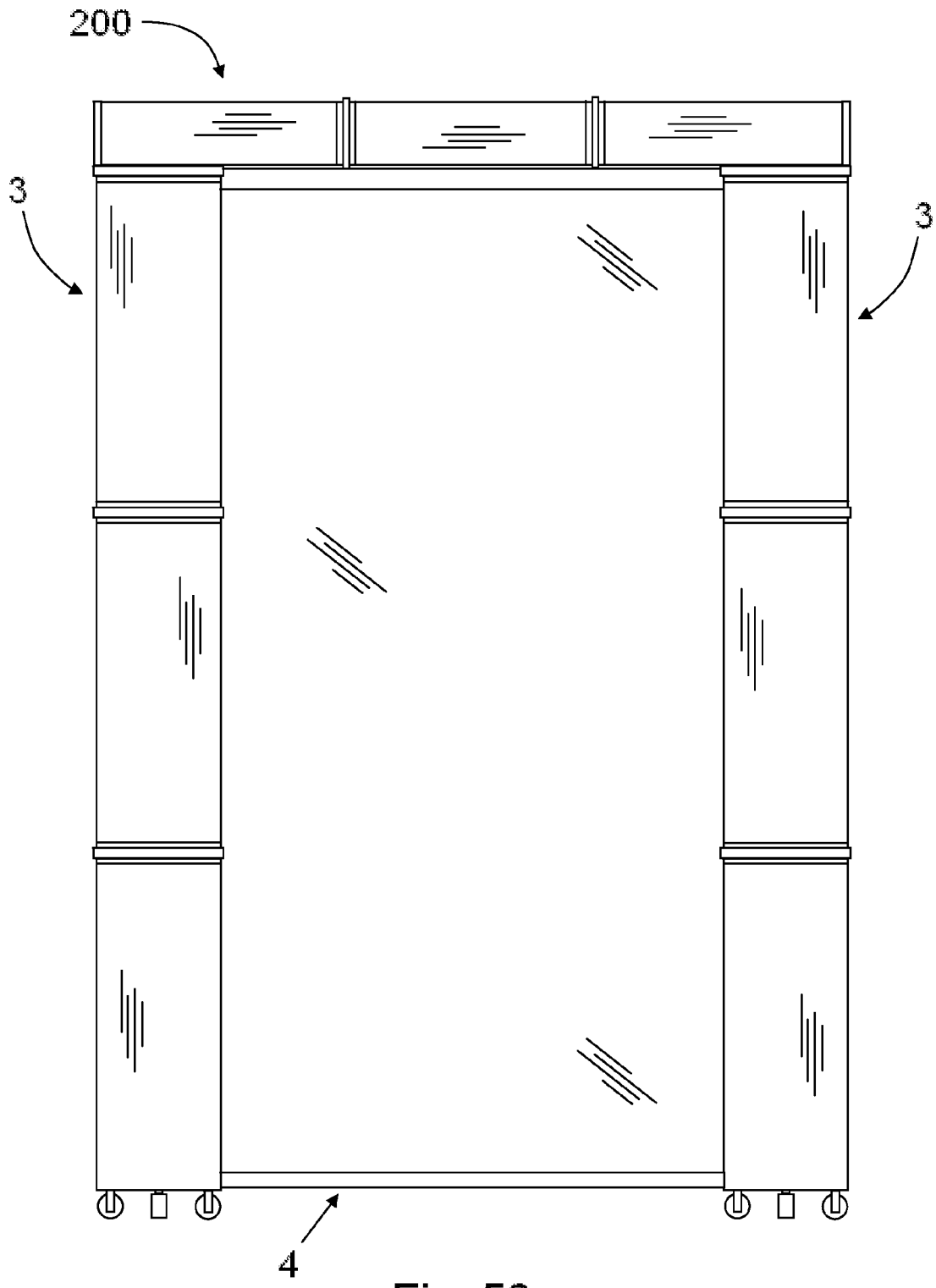

Fig. 50

PORTABLE COLLAPSIBLE MODULAR BACKGROUND SET AND METHOD OF USE

CROSS REFERENCES TO RELATED APPLICATIONS

Not applicable.

BACKGROUND

1. Field of Invention

The present embodiment relates generally to free standing columns, connectors, and backdrops, and methods of use. More particularly, the present embodiment relates to easily-assembled, modular background sets for use in broadcast television, theatre stages, tradeshow booths, and the like, and for displays in other settings, such as retail stores, physician's offices, and the like, that is, wherever information needs to be displayed.

2. State of the Art

The background art is characterized by U.S. Pat. Nos. 4,275,520; 4,561,798; 5,125,205; 5,323,836; 5,439,043; 5,537,766; 5,611,384; 5,826,397; 5,903,993; 6,370,803 B1; 6,643,966 B2; 7,140,307 B1; 7,337,567 B2; and 6,359,218 B1; and U.S. Patent Application Nos. 2003/0046893A1; 2004/0107666A1; 2004/0163778A1; and 2005/0034409A1; the disclosures of which patents and patent application are incorporated by reference as if fully set forth herein.

Non-patent background art is characterized on the following Internet pages: <http://www.displayit.com/10-ft-Standard-Curved-Popup-Trade-Show-Display.aspx>; <http://www.siegeldisplay.com/productdetail.aspx?id=t6005-48237>; <http://www.affordabledisplays.com/shopexd.asp?id=300>; and <http://www.affordabledisplays.com/shopdisplayproducts.asp?id=40>.

SUMMARY OF THE INVENTION

This embodiment provides for a portable, easily-assembled, modular background set that can be used in television studios, theatre stages, and tradeshow booths, to name a few, and for displays in other settings, such as retail stores, physician's offices, and the like, that is, wherever information needs to be displayed. According to this embodiment, an apparatus and method for providing said background set or display comprises a plurality of base structures; a plurality of outer and inner collapsible corrugated plasticboard sleeves; a plurality of supporting frames; a hanger system; an elastic cord stabilizing system; and a collapsible backdrop system. These components are assembled from a very compact, collapsed, disassembled state in a quick and easy manner, with no special tools, to create a professional set or display that can be used in a plurality of different venues.

BRIEF DESCRIPTION OF THE DRAWINGS

FIG. 1 shows a perspective view of one embodiment in its assembled state;

FIG. 2A is a perspective view of the support base of each column of this embodiment;

FIG. 2B is a front elevation view of the support base of this embodiment;

FIG. 2C is a back elevation view of the support base of this embodiment;

FIG. 2D is a right elevation view of the support base of this embodiment;

FIG. 2E is a left elevation view of the support base of this embodiment;

FIG. 2F is a top view of the support base of this embodiment;

5 FIG. 2G is a bottom view of the support base of this embodiment;

FIG. 2H is a top view of an alternate tension cable connection used to keep the column aligned during assembly;

10 FIG. 2I is a right elevation view of the alternate tension cable connection used to keep the column aligned during assembly;

FIGS. 2J through 2M show further alternate embodiments of the support base using an additional alternate tension cable connection;

15 FIG. 3 is a perspective view of the base inner sleeve of this embodiment;

FIGS. 4A, 4B, 4C, 4D, and 4E describe the construction of the base inner sleeve and inner column sleeve of this embodiment;

20 FIG. 5A is a top view of the base inner sleeve of this embodiment;

FIG. 5B is a left elevation view of the base inner sleeve of this embodiment;

25 FIG. 5C is a right elevation view of the base inner sleeve of this embodiment;

FIG. 5D is a front elevation view of the base inner sleeve of this embodiment;

30 FIG. 5E is a back elevation view of the base inner sleeve of this embodiment;

FIGS. 6A, 6B, and 6C describe the method of collapsing the base inner sleeve, and inner column sleeve, of this embodiment, for storage and transport;

35 FIG. 7 is a perspective view of the outer column sleeve of this embodiment;

FIGS. 8A, 8B, 8C, 8D, and 8E describe the construction of the outer column sleeve of this embodiment;

40 FIG. 9A is a top view of the outer column sleeve of this embodiment;

FIG. 9B is a left elevation view of the outer column sleeve of this embodiment;

FIG. 9C is a right elevation view of the outer column sleeve of this embodiment;

45 FIG. 9D is a front elevation view of the outer column sleeve of this embodiment;

FIG. 9E is a back elevation view of the outer column sleeve of this embodiment;

50 FIGS. 10A, 10B, and 10C describe the method of collapsing the outer column sleeve of this embodiment, for storage and transport;

FIG. 11 is a perspective view of the inner column sleeve of this embodiment;

55 FIG. 12A is a top view of the inner column sleeve of this embodiment;

FIG. 12B is a left elevation view of the inner column sleeve of this embodiment;

FIG. 12C is a right elevation view of the inner column sleeve of this embodiment;

60 FIG. 12D is a front elevation view of the inner column sleeve of this embodiment;

FIG. 12E is a back elevation view of the inner column sleeve of this embodiment;

65 FIGS. 13A and 13B show the inner column sleeve support frame, and method of use, in this embodiment;

FIGS. 13C and 13D show the optional outer column support bracket, and method of use, in this embodiment;

FIGS. 13E through 13H show optional inner column sleeve support frames in this embodiment, offering different shapes, featuring shelves and ledges;

FIGS. 14A and 14B show an inner column sleeve support rod, and method of use, in this embodiment;

FIGS. 15A and 15B show an alternate embodiment of an inner column sleeve support rod, and method of use, in this embodiment;

FIGS. 16A and 16B show yet another embodiment of an inner column sleeve support rod, and method of use, in this embodiment;

FIG. 17 shows a plurality of optional outer column sleeve alignment rods, and method of use, in this embodiment;

FIG. 18 shows an alternate type of optional outer column sleeve alignment rods, and method of use, in this embodiment;

FIG. 19 shows the flute-covering material installed on the outer column sleeve in this embodiment;

FIG. 20 shows a backdrop rod hanger in this embodiment;

FIG. 21 shows an alternate type of a backdrop rod hanger that may be used in this embodiment;

FIG. 22 shows a column top cap, and method of use, in this embodiment;

FIG. 23A is a left elevation view of the column top cap ready for installation onto an outer column sleeve in this embodiment;

FIG. 23B is a right elevation view of the column top cap ready for installation onto an outer column sleeve in this embodiment;

FIG. 23C is a front elevation view of the column top cap ready for installation onto an outer column sleeve in this embodiment;

FIG. 23D is a back elevation view of the column top cap ready for installation onto an outer column sleeve in this embodiment;

FIG. 24A is a top view of the column top cap in this embodiment;

FIG. 24B is a bottom view of the column top cap in this embodiment;

FIG. 25A is a perspective view of the column top cap with a set of backdrop rod hangers installed in the rear position of this embodiment;

FIG. 25B is a perspective view of the column top cap with a plurality of alternate types of backdrop rod hangers installed in the side position of this embodiment;

FIG. 25C is a perspective view of the column top cap with a plurality of backdrop rod hangers installed in an off-angle position of this embodiment;

FIG. 25D is a perspective view of the column top cap with an alternate tension cable connection used to optionally keep the column aligned during assembly;

FIG. 26A shows a perspective view and several elevation views of an alternate column top cap of this embodiment;

FIG. 26B shows a perspective view of the alternate column top cap ready for installation onto an outer column sleeve of this embodiment, and a plurality of backdrop rod hangers installed in the rear flutes of an outer column sleeve in this embodiment;

FIG. 26C shows a perspective view of the alternate column top cap installed onto an outer column sleeve of this embodiment, and a plurality of alternate backdrop rod hangers installed in the rear flutes of an outer column sleeve in this embodiment;

FIG. 26D shows a perspective view of an additional column top cap ready for installation onto an outer column

sleeve of this embodiment, and a plurality of backdrop rod hangers installed in rear apertures of the additional column top cap in this embodiment;

FIG. 26E shows a perspective view of an additional column top cap installed in an outer column sleeve of this embodiment, and a plurality of alternate backdrop rod hangers installed in rear apertures of the additional column top cap in this embodiment;

FIG. 27A shows a side view of a tension cable optionally used in this embodiment;

FIG. 27B shows a side view of an alternate tension cable optionally used in this embodiment;

FIG. 27C shows a side view of an additional embodiment of a tension cable optionally used in this embodiment;

FIG. 27D shows a side view of an optional adjustable tension cable optionally used in this embodiment;

FIG. 28A shows a front and side elevation view of an adjustable backdrop rod in this embodiment;

FIG. 28B shows a front and side elevation view of an alternate embodiment of an adjustable backdrop rod in this embodiment;

FIG. 28C shows a front and side elevation view of a fixed backdrop rod in this embodiment;

FIG. 28D shows a front and side elevation view of an alternate embodiment of a fixed backdrop rod in this embodiment;

FIG. 29 describes the installation of the base inner sleeve of a column in this embodiment;

FIG. 30 describes the attachment of the base inner sleeve to the support base of a column in this embodiment;

FIG. 31 describes the installation of the first outer column sleeve of a column in this embodiment;

FIG. 32 describes the final position of the first outer column sleeve in this embodiment;

FIG. 33 describes the installation of an inner column sleeve within an outer column sleeve in this embodiment;

FIG. 34 describes the installation of an inner sleeve support frame, and an optional outer column support bracket, in this embodiment;

FIG. 35 describes the installation of a plurality of optional outer sleeve alignment rods, an inner sleeve support frame, and a second outer sleeve column in this embodiment;

FIG. 36A describes the installation of a column top cap, with installed backdrop rod hangers, onto an outer column sleeve in this embodiment;

FIG. 36B describes the installation of an alternate column cap top, along with a plurality of backdrop rod hangers positioned to install into an outer column sleeve in this embodiment;

FIG. 37 shows the final step of an assembled column using a combination of a plurality of outer column sleeves; a plurality of optional outer sleeve alignment rods; a plurality of optional outer column support brackets; a plurality of inner sleeve support frames; a plurality of inner column sleeves; and a column top cap, with an optional tension cable and a plurality of backdrop rod hangers, in this embodiment;

FIG. 38 shows the final step of an assembled column using a combination of a plurality of outer column sleeves; a plurality of optional outer sleeve alignment rods; a plurality of optional outer column support brackets; a plurality of inner sleeve support frames; a plurality of inner column sleeves; an alternate column top cap with an optional tension cable; and a final outer column sleeve with a plurality of installed backdrop rod hangers in this embodiment;

FIG. 39 shows a perspective view of the assembly of all components of one column in this embodiment;

5

FIG. 40 shows an optional tension cable attached to a column top cap and a support base during the assembly of this embodiment;

FIG. 41A shows a perspective view of an assembled column in this embodiment;

FIG. 41B shows a perspective view of an assembled column with an outer frame shelf, and an additional column top cap, in this embodiment;

FIG. 42 shows the detailed attachment of a plurality of optional tension cable embodiments to a column top cap, and a support base, in this embodiment;

FIG. 43 shows the detailed attachment of an optional tension cable to the alternate column top cap in this embodiment;

FIG. 44 shows one embodiment of a backdrop assembled with a backdrop upper support rod, a backdrop, and a backdrop lower support rod in this embodiment;

FIG. 45 shows a perspective view of the backdrop assembly installed between two assembled columns using a plurality of column top caps, fitted with a plurality of backdrop rod hangers, in this embodiment;

FIG. 46 shows a perspective view of the backdrop assembly installed between two assembled columns using a plurality of alternate column top caps, and a plurality of outer column sleeves fitted with a plurality of backdrop rod hangers, in this embodiment;

FIG. 47 shows a top view of an alternate modular background set configuration with wing-backdrops configured at 45-degree angles in an alternate embodiment;

FIG. 48 shows a top view of another modular background set configuration with wing-backdrops configured at 90-degree angles in an additional embodiment;

FIG. 49 shows the assembly of a lentil, and method of attachment of the lentil to two columns in yet another embodiment; and

FIG. 50 shows the final assembly of the lentil embodiment.

DETAILED DESCRIPTION

One Embodiment—FIGS. 1-27, and FIG. 39

With reference now to the drawings, FIG. 1 through FIG. 28 (A, B, C, and D), and FIG. 44, illustrate the components of one embodiment. As shown in FIG. 1, in this embodiment, a modular background set 1 consists of a plurality of completed columns 3 and a backdrop assembly 4.

As seen in FIG. 2 through FIG. 27 (A, B, C, and D), column 3 is comprised of a support base assembly 5, a base inner sleeve 30, a plurality of outer column sleeves 50, a plurality of inner column sleeves 70, a plurality of inner sleeve support frames 80, a plurality of curved backdrop rod hangers 107, a column top cap 112, and a tension cable 130.

Turning now to FIGS. 2A through 2G, support base assembly 5 is comprised of a support base 6, a column wall attachment assembly 7, and a plurality of casters 20. For this embodiment, support base 6 and attachment assembly 7 are preferably made from a cellular (closed cell) utility polymer sheet material, such as King StarLite® XL, available from Piedmont Plastics in Memphis, Tenn., using conventional machining methods, such as cutting or milling. King StarLite® XL is available in a variety of thicknesses and colors. For this embodiment Utility Black StarLite® XL was used with various thicknesses. Alternatively, support base 6 and attachment assembly 7 may be made from other durable materials, such as other plastics, wood, metal, or other materials, using alternative manufacturing processes such as injection molding, wire electrical discharge machining (wire EDM); chemical etching machining; abrasive water jet

6

machining; or laser machining, e.g., Stereolithography (SLA), Selective Laser Sintering (SLS), or laser cutting; to name a few.

In this embodiment support base 6 measures 17.125-inches wide by 15.125-inches deep with a thickness of 0.5-inches. As shown in FIGS. 2F and 2G, support base 6 includes a plurality of cutout slots 17 intended to reduce the weight of support base assembly 5 to enhance its portability, although cutout slots 17 may be omitted without disrupting the functionality. Support base assembly 5 may be further described by two subsections: a footpad section 16, which is also used as a counterweight, and a column support section 18, which provides support for the assembled column components. In this embodiment footpad section 16 is shown with a rounded shape 21 to: facilitate further weight reduction; enhance the portability; and provide an ergonomic appearance; although footpad section 16 could be machined to other shapes without disrupting the functionality. Column support section 18 further includes a lower tension cable slot 27, used to keep the column aligned during assembly (described in a later section of the Specification). In an alternate embodiment, as shown in FIGS. 2H and 2I, column support section 18 includes a lower tension hook 25, which engages the top surface of column support section 18, and is subsequently used to keep the column aligned during assembly (described in a later section of the Specification). Lower tension hook 25 preferably has a 3/8-inch eye hook opening with a 2-inch long, #8 wood screw shaft, and is available from Aubuchon Hardware, Putnam, Conn., P/N Model #130-08915, although other eye sizes and shaft lengths will suffice.

As shown in FIGS. 2B through 2G, wall attachment assembly 7 is comprised of a plurality of attachment supports: a front attachment wall 8; a back attachment wall 10; a right attachment wall 12; and a left attachment wall 14. In the current embodiment attachment walls 8, 10, 12 and 14 measure 0.625-inches thick and 1.5-inches high. Front attachment wall 8 measures 15.6-inches long; back attachment wall 10 measures 14.35-inches long; right attachment wall 12 measures 5.0-inches long; and left attachment wall 14 measures 6.3-inches long. Note that other thicknesses, heights and lengths could be used. Attachment walls 8, 10, 12 and 14 attach to column support section 18 using a plurality of attachment wall fasteners 24. In the current embodiment, attachment wall fasteners 24 are 1-inch long, #6 wood screws, P/N 87906137, available from MSC Industrial Supply, located in Melville, N.Y., which are inserted through a plurality of attachment wall fastener apertures 15 and subsequently engage attachment walls 8, 10, 12 and 14 to securely fasten them to column support section 18, although attachment walls 8, 10, 12 and 14 could be attached to column support section 18 using a variety of other attachment means, such as adhesive, nails, etc. Attachment walls 8, 10, 12 and 14 also have a plurality of support base fastener apertures 22, with diameters measuring 0.2-inches in the current embodiment, although support base fastener apertures 22 may be threaded to accept machine threaded screws or bolts, such as a #6-32 size. Support base fastener apertures 22 are used in the assembly of this embodiment's column, to be detailed later in the Specification. As seen in FIG. 2F, a support base attachment wall gap 19 also provides a space needed in the assembly of this embodiment's column, as detailed later in the Specification.

Lastly, casters 20 are attached to the bottom surface of support base 6. In the current embodiment, three 2.25-inch diameter swivel casters, such as a Nylon hooded plate, twin wheel caster, P/N 24215T46, available from McMaster-Carr Supply Company, located in Atlanta, Ga., are attached to

support base **6** using a plurality of caster fasteners **26** (FIG. 2E), such as a 0.625-inch long, #8 wood screws, P/N 87906269, available from MSC Industrial Supply, although other fasteners may be used to attach casters **20** to support base **6**, such as bolt-nut combinations, rivets, etc. Additionally, pop-out, socket-mounted casters may be used whereby the wheel can be removed when not in use, further adding to the portability of this embodiment. Alternately, base **5** may not need to be on casters, and thus other components, such as Easy-Slide Glides, P/N 2551T36 from McMaster Carr, of Atlanta, Ga., may be used instead, allowing the completed column **3** to be moved by sliding it on a surface.

Finally, FIGS. 2J through 2M show alternate shapes of support base assembly **5**, which enhance this embodiment's ergonomic appearance, without disrupting the functionality. That is, support base assembly **5** can be designed in a variety of configurations to meet special requirements of different installation environments.

Turning now to FIGS. 3; 4A to 4E; 5A to 5E; and 6A to 6C; base inner sleeve **30** is preferably made from corrugated plastic sheets, commonly referred to as Coroplast®, available from Coroplast, Inc. of Dallas, Tex., although other types of corrugated material may be used, such as corrugated fiberboard, corrugated cardboard, etc. Coroplast® is available in a variety of lengths, widths, thicknesses and colors. For this embodiment base inner sleeve **30** is constructed from $\frac{5}{32}$ -inch (4-mm) thick Coroplast® in a JM Gray Utility Gray color, although other thicknesses and colors may be used. Turning now to FIG. 3, in the present embodiment, base inner sleeve **30** measures 15.9-inches wide by 6.625 inches deep by 15-inches high (outside dimensions). As shown in FIGS. 4A through 4E, and FIGS. 5A through 5E, base inner sleeve **30** is formed from an initial corrugated plastic sheet **32** with dimensions of 47-inches (L) by 15-inches (W) by $\frac{5}{32}$ -inch thick. A back surface **35**, with an outside dimension of 15.9 inches, is formed by implementing a first inner sleeve bend **34**. First inner sleeve bend **34** is facilitated by scoring/cutting the inside surface of back surface **35** at the position of the bend. A left surface **37**, with an outside dimension of 6.625 inches, is formed by implementing a second inner sleeve bend **36**. Second inner sleeve bend **36** is facilitated by scoring/cutting the inside surface of left surface **37** at the position of the bend. A front surface **39**, with an outside dimension of 15.9 inches, is formed by implementing a third inner sleeve bend **38**. Third inner sleeve bend **38** is facilitated by scoring/cutting the inside surface of front surface **39** at the position of the bend. As shown in FIG. 4D, an adhesive **40**, such as a 3M® double-sided foam tape, P/N 00021200232053, available from MSC Industrial Supply, with a 1-inch width, is applied along the total height of corrugated plastic sheet **32** to a tab attachment area **41**. Adhesive **40** can also be of another type, such as Velcro® strips, epoxy, etc. A right surface **43**, with an outside dimension of 6.625 inches, is formed by implementing a fourth inner sleeve bend **42**. Fourth inner sleeve bend **42** is facilitated by scoring/cutting the inside surface of right surface **43** at the position of the bend. Fourth inner sleeve bend **42** also places tab attachment area **41**, with a width of 1.95 inches, in a position to complete the formation of base inner sleeve **30** by pressing the inside of back surface **35** against adhesive **40** (see FIG. 4E). Once base inner sleeve **30** is constructed, a first instruction label **160**, with an adhesive backing, is attached to the center of the inside surface of back surface **35** approximately 1-inch from the top of base inner sleeve **30**. First instruction label **160** may contain several types of information including installation instructions, part numbers, etc. Turning now to FIGS. 5A through 5E, in the present embodiment, base inner sleeve **30** includes a plurality

of base inner sleeve attachment apertures **44**, measuring 0.25" in diameter in the current embodiment, although other diameters would suffice, which are used with support base fastener apertures **22** in the assembly of this embodiment's column **3**. Optionally, a rubber grommet, such as a McMaster Carr Part #9307K38, with a 0.25-inch ID, a 0.625-inch OD, and a panel thickness of $\frac{3}{16}$ -inches, can be installed in apertures **44** to add support during assembly and disassembly. Additionally, base inner sleeve **30** further includes an access aperture **49**, measuring 5-inches in width by 5-inches in height, which is located in the center of back surface **35**, and 1-inch from the bottom of base inner sleeve **30**. Access aperture **49** is used during the assembly of column **3**, as described later in the Specification. FIGS. 6A, 6B and 6C demonstrate the collapsibility, and thus portability, of this embodiment of base inner sleeve **30**. In FIG. 6A, base inner sleeve **30** is shown in its expanded state, and ready for assembly. As shown in FIG. 6B, base inner sleeve **30** is collapsed by apply a plurality of collapsing forces **45**, which in turn cause front surface **39** and right surface **43** to align in a first collapsing direction **46**, and left surface **37** and back surface **35** to align in a second collapsing direction **48**, resulting in a collapsed, two surface configuration as shown in FIG. 6C. In this embodiment, the 6.625 inch deep base inner sleeve **30** is reduced to about 0.5-inches depth after it is collapsed, making for very easy storage and transportation in a small box, suitcase, or similar enclosure.

Turning now to FIGS. 7; 8A to 8E; 9A to 9E; and 10A to 10C; outer column sleeve **50** is preferably made from corrugated plastic sheets, commonly referred to as Coroplast®, although other types of corrugated material may be used, such as corrugated fiberboard, corrugated cardboard, etc. For this embodiment outer column sleeve **50** is constructed from $\frac{5}{32}$ -inch (4-mm) thick Coroplast® in a JM Utility Gray color, although other thicknesses and colors may be used. Turning now to FIG. 7, in the present embodiment, outer column sleeve **50** measures 16.5-inches wide by 7.0 inches deep by 31.5-inches high (outside dimensions). As shown in FIGS. 8A through 8E, and FIGS. 9A through 9E, outer column sleeve **50** is formed from an outer corrugated plastic sheet **52** with dimensions of 48-inches (L) by 31.5-inches (W) by $\frac{5}{32}$ -inch thick. An outer sleeve back surface **55**, measuring 16.5 inches, is formed by implementing a first outer sleeve bend **54**. First outer sleeve bend **54** is facilitated by scoring/cutting the outside surface of outer sleeve back surface **55** at the position of the bend. Once first outer sleeve bend **54** is made, an inner sleeve support shelf **64**, measuring 1-inch high by 6.5-inches long by 0.50-inches thick, and comprised of a self-adhesive, extruded polystyrene foam laminated between clay-coated paper liners (often called foam core board, P/N PSFB-700, available from FoamBoardSource.com) is centered and attached approximately 5-inches from the top of the inside of outer sleeve back surface **55**. Alternatively, a foam core board without self-adhesive could be used by applying a double-sided adhesive tape, epoxy, or some other type of attachment means. Additionally, other lightweight, but sturdy, materials could be used for inner sleeve support shelf **64**. An outer sleeve left surface **57**, measuring 7.0 inches, is formed by implementing a second outer sleeve bend **56**. Second outer sleeve bend **56** is facilitated by scoring/cutting the outside surface of outer sleeve left surface **57** at the position of the bend. An outer sleeve front surface **59**, measuring 16.5 inches, is formed by implementing a third outer sleeve bend **58**. Third outer sleeve bend **58** is facilitated by scoring/cutting the outside surface of outer sleeve front surface **59** at the position of the bend. Once third outer sleeve bend **58** is made, a second inner sleeve support shelf **64** is centered and

attached approximately 5-inches from the top of the inside of outer sleeve front surface 59. As shown in FIG. 8D, adhesive 40 is applied along the total height of outer corrugated plastic sheet 52 to an outer sleeve tab attachment area 61. An outer sleeve right surface 63, measuring 7.0 inches, is formed by implementing a fourth outer sleeve bend 62. Fourth outer sleeve bend 62 is facilitated by scoring/cutting the outside surface of outer sleeve right surface 63 at the position of the bend. Fourth outer sleeve bend 62 also places outer sleeve tab attachment area 61, with a width of 1.0 inch, in a position to complete the formation of outer column sleeve 50 by pressing outer sleeve back surface 55 against adhesive 40, as shown in FIG. 8E. Turning now to FIGS. 9A to 9E, once outer column sleeve 50 is constructed, a second instruction label 170, with an adhesive backing, is attached to the center of the inside surface of outer sleeve back surface 55 approximately 1-inch from the top of outer column sleeve 50, and just above inner sleeve support shelf 64. Second instruction label 170 may contain several types of information including installation instructions, part numbers, etc. Additionally, outer column sleeve 50 further includes an outer sleeve access aperture 66, measuring 5-inches in width by 5-inches in height, which is located in the center of outer sleeve back surface 55, and 1-inch from the bottom of outer column sleeve 50. Outer sleeve access aperture 66 is used during the assembly of column 3, as described later in the Specification. FIGS. 10A, 10B and 10C demonstrate the collapsibility, and thus portability, of this embodiment's outer column sleeve 50. In FIG. 10A, outer column sleeve 50 is shown in its expanded state, and ready for assembly. As shown in FIG. 10B, outer column sleeve 50 is collapsed by applying collapsing forces 45, which in turn cause outer sleeve left surface 57 and outer sleeve front surface 59 to align in second collapsing direction 48, and outer sleeve right surface 63 and outer sleeve back surface 55 to align in first collapsing direction 46, resulting in a collapsed, two surface configuration as shown in FIG. 10C. In this embodiment, the 7.0-inch deep outer column sleeve 50 is reduced to about 1.5-inches depth (depends on the depth of inner sleeve support shelf 64) after it is collapsed, making for very easy storage and transportation in a small box, suitcase, or similar enclosure. In the current embodiment, outer column sleeve 50 displays a gray color inherent to base corrugated plastic sheet 52, however, outer column sleeve 50 may also display images, such as company logos, custom scenes, or text, implemented via a decal or screen printing applied to corrugated plastic sheet 52. Likewise, corrugated plastic sheet 52 may be covered with wall covering material, such as Medium Oak Natural Brown faux wood grain vinyl wall covering, P/N WWX405, available from Design Your Wall, Inc., of Van Nuys, Calif., causing outer column sleeve 50 to resemble wood, although many other wall covering patterns, such as faux stone or brick, or laminate, could be used. That is, outer column sleeve 50 is capable of providing many variations of visually appealing columns suited for a variety of settings.

Turning now to FIGS. 11, and 12A through 12E, inner column sleeve 70 is preferably made from corrugated plastic sheets, commonly referred to as Coroplast®, although other types of corrugated material may be used, such as corrugated fiberboard, corrugated cardboard, etc. Coroplast® is available in a variety of lengths, widths, thicknesses and colors. For this embodiment inner column sleeve 70 is constructed from 5/32-inch (4-mm) thick Coroplast® in a JM Gray Utility Gray color, although other thicknesses and colors may be used. Turning now to FIG. 11, in the present embodiment, inner column sleeve 70 measures 15.9-inches wide by 6.625 inches deep by 15-inches high (outside dimensions). As

shown in FIGS. 12A through 12E, inner column sleeve 70 is formed in the same manner as base inner sleeve 30 above, using the same material (corrugated plastic sheet 32), except that a third instruction label 174 is attached, as opposed to first instruction label 160. Third instruction label 174 may contain several types of information including installation instructions, part numbers, etc. Inner column sleeve 70 can be collapsed in the same manner as described for base inner sleeve 30 above, resulting in the same compact size for storage and transportation.

Turning now to FIGS. 13A, 13B, 13C and 13D, inner sleeve support frame 80, which keeps outer column sleeve 50, base inner sleeve 30, and inner column sleeve 70 corners more square, is preferably made from a closed cell polymerized vinyl chloride (PVC) material, such as Sintra®, which is lightweight with a high-stiffness; is available in a variety of thicknesses and colors; and can be cut, milled, routed or drilled to form many shapes. Note that other stiff, lightweight materials could be used, such as cellular utility polymer sheet material (e.g., King StarLite® XL); acetal plastics (e.g., Delrin®); and Polyamide (Nylon); to name a few. For this embodiment inner sleeve support frame 80 is constructed from 1/2-inch (13-mm) thick Sintra® in a black color, although other thicknesses and colors may be used. In the present embodiment, inner sleeve support frame 80 measures 16.9-inches wide by 7.625 inches deep by 1/2-inches high (outside dimensions), with an internal cutout 81 measuring 16.0-inches wide by 6.75 inches deep, allowing it to fit around inner column sleeve 70 in an installation direction 84, as seen in FIGS. 13B and 13D, thus keeping it more square. Inner sleeve support frame 80 optionally includes a plurality of alignment dowel apertures 82, which may optionally be used during the assembly of column 3 (described later in the Specification). To add optional support for outer column sleeve 50 during assembly (described later in the Specification), an outer column support bracket 85, preferably made from polymer sheet material (e.g., King StarLite® XL), although other materials, such as other plastics, aluminum, or wood could be used, and measuring 4-inches wide by 4-inches high by 0.1-inches thick in the current embodiment, may be attached to each shorter side of inner sleeve support frame 80, either by a plurality of bracket attachment fasteners 86 (such as a #6-32, by 1/2-inch long machine screw, available from MSC Industrial) engaging a plurality of threaded support bracket attachment apertures 89, or by an adhesive. Outer column support bracket 85 further includes a plurality of threaded support bracket apertures 87 which accept a plurality of outer column sleeve fasteners 88 and a plurality of washers 167 (used in the assembly of column 3 described later in the Specification). Additionally, as shown in FIGS. 13E through 13H, inner sleeve support frame 80 may be made in different shapes to add further functionality to this embodiment. A plurality of alternate inner sleeve support frames 74, 75, 76 and 77 are shown with a plurality of various support frame shelves 78. Support frame shelves 78 add additional surface area for placing supplementary items used in tradeshow, broadcast television studios, etc., such as brochures, display monitors, and speakers, to name a few.

Alternatively, base inner sleeve 30 and inner column sleeve 70 (and thus outer column sleeve 50) may be kept more square by other types of structures, as shown in FIGS. 14A and 14B; 15A and 15B; and 16A and 16B. FIGS. 14A and 14B illustrate one approach using a single support rod 92. In the current embodiment, alternate single support rod 92 is made from a 19.3-inch long, 3/16-inch diameter 5052/H32 aluminum rod, available from Alloy Products Division of G.M.F. Industries, Inc. in Florida. Single support rod 92 is further formed by

bending a plurality of one-inch long insert segments **93** at both ends of single support rod **92**. As shown in FIG. **14B**, insert segments **93** are inserted into a plurality of corrugated plastic sheet flutes **90** located at diagonally-opposite corners of base inner sleeve **30** (at a distance of 17.3-inches). FIGS. **15A** and **15B** describe another alternate approach using a diagonal cross support rod **94**. In the current embodiment alternate diagonal cross support rod **94** is formed by joining two single support rods **92** in such a manner as to create a diagonal configuration. Single support rods **92** are preferably joined at a joint **95** by a welding method, although other methods for joining metals may be used, such as Araldite® 2021 epoxy, pop rivets, etc. Alternate diagonal cross support rod **94** is then inserted into a plurality of corrugated plastic sheet flutes **90** located at diagonally-opposite corners of base inner sleeve **30**. Alternately, single support rods **92** do not have to be joined at joint **95**, that is, one single support rod **92** can be inserted first, followed by a second single support rod **92** as shown. FIGS. **16A** and **16B** describe yet another alternate approach using an orthogonal cross support rod **96**. In the current embodiment alternate orthogonal cross support rod **96** is formed by joining two single rods in such a manner as to create an orthogonal configuration. A first support rod **98** is preferably made from a 17.9-inch long, $\frac{3}{16}$ -inch diameter 5052/H32 aluminum rod, available from Alloy Products Division of G.M.F. Industries, Inc. in Florida. First support rod **98** is further formed by bending a plurality of one-inch long orthogonal insert segments **97** at both ends of first support rod **98**. A second support rod **99** is preferably made from a 8.625-inch long, $\frac{3}{16}$ -inch diameter 5052/H32 aluminum rod, available from Alloy Products Division of G.M.F. Industries, Inc. in Florida. Second support rod **99** is further formed by bending a plurality of one-inch long orthogonal insert segments **97** at both ends of second support rod **99**. As seen in FIG. **16A**, alternate orthogonal cross support rod **96** is formed by joining second support rod **99** under first support rod **98** at joint **95**, at a 90-degree angle, preferably by a welding method, although other methods for joining metals may be used, such as Araldite® 2021 epoxy, pop rivets, etc. Alternate orthogonal cross support rod **96** is then inserted into a plurality of corrugated plastic sheet flutes **90** located at orthogonal positions in inner column sleeve **70** as seen in FIG. **16B**.

Turning now to FIG. **17**, a circular outer sleeve alignment rod **100**, which may optionally be used to align outer column sleeves **50** during assembly, is preferably made from a lightweight, but stiff plastic rod, such as Nylon 6/6, available from MSC Industrial, MSC P/N: 63393342, although other materials could be used, such as Delrin®, Acrylonitrile Butadiene Styrene (ABS), aluminum, etc. In the current embodiment circular outer sleeve alignment rod **100** is preferably 5-inches long with a $\frac{3}{16}$ -inch diameter. FIG. **18** describes a rectangular outer sleeve alignment rod **104**, which is an additional element for aligning outer column sleeves **50** during assembly. Rectangular outer sleeve alignment rod **104** is preferably made from a lightweight, but stiff plastic bar, such as Nylon 6/6, available from Small Parts Inc., Miami Lakes, Fla., P/N: U-SRN-0187, although other materials could be used, such as Delrin®, Acrylonitrile Butadiene Styrene (ABS), aluminum, etc. In the current embodiment rectangular outer sleeve alignment rod **104** is preferably 5-inches long with a $\frac{3}{16}$ -inch width by $\frac{3}{16}$ -inch depth. Note that other shapes, such as hexagonal, could be used for the alignment rods.

Turning now to FIG. **19**, an optional flute covering **106** is shown covering a plurality of corrugated plastic sheet flutes **90**. Flute covering **106** provides visual aesthetics by hiding corrugated plastic sheet flutes **90** from sight. In this embodiment, flute covering **106** is preferably made from a strong,

tough, cotton cloth pressure sensitive tape, often termed gaffer's tape, available from Identi-Tape, Inc. in Boulder, Colo., P/N: g.5gy, although other tapes or coverings could be used. In the current embodiment, flute covering **106** is preferably $\frac{1}{2}$ -inch wide, in a Gray color.

Turning now to FIG. **20**, a side view of curved backdrop rod hanger **107** is shown. A plurality of curved backdrop rod hangers **107** are used during the assembly process to support backdrop assembly **4**. In the current embodiment curved backdrop rod hanger **107** is preferably formed from a $\frac{1}{8}$ -inch diameter, 6.5-inch long type 316 stainless steel rod material, available from Small Parts Inc., Miami Lakes, Fla., P/N: U-ZRXX-2-6, although other materials could be used, such as other low-carbon steel materials, brass, etc. Curved backdrop rod hanger **107** is further formed by bending the 6.5-inch rod to form a circular backdrop rod opening **109**, which is a 1.25-inch diameter "C" shape opening, and a straight shaft **110**, measuring 3.25-inches, for insertion into one of a plurality of corrugated plastic sheet flutes **90**. FIG. **21** shows an alternate rectangular backdrop rod hanger **108** is preferably formed from a 6.5-inch long, $\frac{1}{8}$ -inch by $\frac{1}{8}$ -inch, type 316 stainless steel bar material, available from Small Parts Inc., Miami Lakes, Fla., P/N: U-ZSXX-2-6, although other materials could be used, such as other low-carbon steel materials, brass, etc. Rectangular backdrop rod hanger **108** is further formed by bending the 6.5-inch rod to form a rectangular backdrop rod opening **111**, measuring 1.0-inch (high) by 1.25-inches (width), which resembles a rectangular opening, and straight shaft **110**, measuring 3.25-inches, for insertion into one of a plurality of corrugated plastic sheet flutes **90**. Alternatively, curved backdrop rod hanger **107** and rectangular backdrop rod hanger **108** could be formed from other techniques, such as metal injection molding (MIM).

Turning now to FIGS. **22**; **23A** through **23D**; **24A** and **24B**; and **25A** through **25D**, column top cap **112**, which offers support for curved backdrop rod hanger **107** (or rectangular backdrop rod hanger **108**), and allows for various multi-column configurations (seen later in the Specification), is comprised of two components: a column top outer member **113** and a column top inner member **115**. Column top outer member **113** is preferably made from a cellular utility polymer sheet material, such as King StarLite® XL, available from Piedmont Plastics in Memphis, Tenn., using conventional machining methods, such as cutting or milling. King StarLite® XL is available in a variety of thicknesses and colors. For this embodiment Utility Black StarLite® XL was used. Alternatively, column top outer member **113** may be made from other durable materials, such as other plastics, wood, metal, or other materials, using alternative manufacturing processes such as injection molding, wire electrical discharge machining (wire EDM); chemical etching machining; abrasive water jet machining; or laser machining, e.g., Stereolithography (SLA), Selective Laser Sintering (SLS), or laser cutting; to name a few. In this embodiment column top outer member **113** in general measures 16.5-inches wide by 12-inches deep with a thickness of 0.5-inches. As shown in FIG. **22**, column top outer member **113** includes a plurality of outer member slots **125**, each measuring 6.9-inches wide by 4.6 inches deep, intended to reduce the weight of column top cap **112** in order to enhance its portability; an upper tension cable slot **127**, used to keep the column aligned during assembly (described in a later section of the Specification); and an outer member grip slot **126**, intended to reduce the weight of column top outer member **113**, and to facilitate the use of a column top cap handle **118** by allowing the user's fingers to grip handle **118** to manipulate column **3**. As seen in FIGS. **24A** and **24B**, column top outer member **113** is further

13

machined with a top cap angle **119**, set to 45-degrees in the present embodiment, to facilitate the use of additional columns placed at 45-degree angles (additional columns will be discussed later in the Specification), although top cap angle **119** could be machined to other angles to form different background configurations. Column top outer member **113** further contains a plurality of backdrop rod hanger apertures **114** to receive curved backdrop rod hangers **107**, and a plurality of outer member lintel attachment apertures **116** to facilitate the optional attachment of a lintel **200** (as presented later in the Specification).

As shown in FIGS. **23A** through **23D**, and **24B**, column top inner member **115** is preferably made from a closed cell polymerized vinyl chloride (PVC) material, such as Sintra®, which is lightweight with a high-stiffness; is available in a variety of thicknesses and colors; and can be cut, milled, routed or drilled to form many shapes. Note that other stiff, lightweight materials could be used, such as cellular utility polymer sheet material (e.g., King StarLite® XL); acetal plastics (e.g., Delrin®); and Polyamide (Nylon); to name a few. For this embodiment column top inner member **115** is constructed from ½-inch (13-mm) thick, adhesive-backed Sintra® in a black color, although other thicknesses and colors may be used. In the present embodiment, column top inner member **115** in general measures 16.0-inches wide by 6.5 inches by ½-inch high (outside dimensions), allowing it to fit within outer column sleeve **50** as seen in FIGS. **23A** through **23D**. As seen in FIGS. **24A** and **24B**, column top inner member **115** further has a plurality of inner member slots **124** measuring 6.9-inches wide by 4.6 inches deep, which align with outer member slots **125**, and are intended to reduce the weight of column top cap **112**. Column top inner member **115** further contains a plurality of inner member backdrop rod hanger apertures **121**, which align with backdrop rod hanger apertures **114**. Column top inner member **115** further contains a plurality of inner member lintel attachment apertures **117**, which align with outer member lintel attachment apertures **116**, to facilitate the optional attachment of lintel **200** (as seen later in the Specification). Column top cap **112** is formed by attaching adhesive-backed column top inner member **115** to the bottom surface of column top outer member **113**, taking care to align outer member lintel attachment apertures **116** with inner member lintel attachment apertures **117**, backdrop rod hanger apertures **114** with inner member backdrop rod hanger apertures **121**, and outer member slots **125** to inner member slots **124**. Alternately, column top inner member **115** may be attached to column top outer member **113** by other fastening methods, including epoxy, screws, etc.

FIGS. **25A** through **25C**, describe the installation locations of curved backdrop rod hangers **107**, or rectangular backdrop rod hangers **108**, or other hanger types. Depending on modular background set **1** design, hangers may be placed on column top cap **112** in various backdrop rod hanger apertures **114**, to form several different backdrop configurations. FIG. **25A** shows the rear mounting position. FIG. **25B** shows the side mounting position (using alternate rectangular backdrop rod hangers **108**). FIG. **25C** shows the mounting position of curved backdrop rod hangers **107** for forming the non-orthogonal wing configuration.

FIG. **25D** describes an alternate embodiment of column top cap **112**, wherein column top cap **112** includes an upper tension hook **128**, which engages the bottom surface of column top cap **112** by screwing upper tension hook **128** into the bottom surface of column top cap **112**. Upper tension hook **128** is subsequently used to keep the column aligned during assembly (described in a later section of the Specification). Upper tension hook **128** preferably has a ¾-inch eye hook

14

opening with a 2-inch, #8 wood screw shaft, and is available from Aubuchon Hardware, Putnam, Conn., P/N Model #130-08915, although other eye sizes and shaft lengths will suffice.

FIGS. **26A** through **26C** describe a second column top cap **129**. Second column top cap **129** is preferably made from corrugated plastic sheets, commonly referred to as Coroplast®, available from Coroplast, Inc. of Dallas, Tex., although other types of corrugated material may be used, such as corrugated fiberboard, corrugated cardboard, etc. Coroplast® is available in a variety of lengths, widths, thicknesses and colors. For this embodiment second column top cap **129** is constructed from ½-inch (4-mm) thick Coroplast® in a JM Gray Utility Gray color, and measures 16.0-inches wide by 6.5 inches deep, although other thicknesses and colors may be used. Second column top cap **129** further contains a column top cable aperture **190**, measuring ¼-inch in diameter, which is centered in second column top cap **129**. When installed, second column top cap **129** rests on a plurality of support shelves **64**, which have been attached to the inner surfaces of a final outer column sleeves **50** approximately 0.25-inches from the top of outer column sleeve **50**. Further, in this alternate embodiment, curved backdrop rod hangers **107**, or rectangular backdrop rod hangers **108**, are inserted directly into corrugated plastic sheet flutes **90** in outer column sleeves **50**, as shown in FIGS. **26B** and **26C**.

FIGS. **26D** and **26E** show a third column top cap **156**. Third column top cap **156** is comprised of two components: a third column top cap outer member **159** and a plurality of third column top support walls **158**. Third column top cap **156** is preferably made from a closed cell polymerized vinyl chloride (PVC) material, such as Sintra®, (Utility Black StarLite® XL is used for this embodiment), which is lightweight with a high-stiffness; is available in a variety of thicknesses and colors; and can be cut, milled, routed or drilled to form many shapes. Note that other stiff, lightweight materials could be used, such as cellular utility polymer sheet material (e.g., King StarLite® XL); acetal plastics (e.g., Delrin®); and Polyamide (Nylon); to name a few. Third column top cap outer member **159** also contains an upper tension cable slot **127**, used to keep the column aligned during assembly (described in a later section of the Specification), and a plurality of backdrop rod hanger apertures **114** used to accept curved backdrop rod hanger **107**, or rectangular backdrop rod hanger **108**, or some other type of backdrop rod hanger device. Third column top support walls **158** measure 16-inches long by 2-inches deep by 0.5-inches wide and may attach to third column top cap outer member **159** using a variety of fastening methods, including epoxy, screws, etc. Third column top support walls **158** are positioned on third column top cap outer member **159** such that third column top cap **156** can frictionally fit within outer column sleeve **50** (see FIG. **26E**).

FIGS. **27A** through **27D** show a number of embodiments of tension cables. FIG. **27A** shows tension cable **130**, which consists of an elastic cable **139** and a set of endpieces **131**. In one embodiment, elastic cable **139** is ¾-inch in diameter, 7-feet in length, and composed of one or more elastic strands forming a core, covered in a woven nylon or cotton sheath, and is available from htbbungeecords.com. In one embodiment, endpiece **131** is made from polymer sheet material (e.g., King StarLite® XL), although other plastics, aluminum, wood, or other materials could be used, and measures 1-inch wide by 1-inch long by 0.25-inches thick, with a 0.25-inch diameter hole centered in the 1-inch by 1-inch material, in the current embodiment. FIG. **27B** shows an alternate tension cable **132** which consists of elastic cable **139** and a set of alternate endpieces **133**. In one embodiment, alternate endpiece **133** is made from a rubber material, with a 0.8-inch

15

diameter top tapering to a 0.6-inch diameter bottom, with a 0.2-inch diameter hole, centered at the top and bottom of alternate endpiece **133**, and continuing through alternate endpiece **133** from top to bottom. Alternate endpiece **133** can be obtained from MSC Industrial, P/N C-2686. Alternate endpiece **133** can also be constructed from plastic, aluminum, wood, or other materials. Additionally, alternate endpiece **133** could be a rubber or plastic washer or grommet. That is, alternate endpiece **133** can be made from a variety of materials in a variety of shapes. FIG. 27C shows an additional tension cable **134**, which consists of elastic cable **139** and a set of additional endpieces **135**. Additional endpiece **135** is preferably a hook that attaches to elastic cable **139**, and is available from www.htbbungeecords.com, P/N Cord Hook J Style $\frac{3}{16}$. Alternately, additional tension cable **134** can be purchased already assembled from www.htbbungeecords.com, P/N $\frac{3}{16}$ " CJH-7' (B). FIG. 27D shows an adjustable tension cable **136**, which consists of elastic cable **139**, additional endpieces **135**, and a tension cable adjuster **137**, available from MSC Industrial, P/N 05140-8. Further, tension cables could be constructed from a combination of an elastic cable, a fixed cable, such as a rope material or metal, and a set of endpieces selected from above. Even further, tension cables can be constructed from different endpieces located at each end of the cable, that is, there are a number of combinations of cables and endpieces that can form the tension cable.

FIGS. 28A through 28D show a plurality of different methods for supporting backdrop assembly **4**. FIG. 28A shows a backdrop support rod **140** consisting of a support rod inner section **141**, with a rectangular shape, and a support rod outer section **142** with a rectangular "C" shape. Support rod inner section **141** is formed in such a way as to move in and out of support rod outer section **142** allowing support rod **140** to be made variable in length. In the current embodiment, support rod outer section **142** is made from aluminum, and measures $\frac{7}{16}$ -inches wide by $\frac{11}{16}$ -inch high by 36-inches long (outside dimensions), with an inner opening measuring $\frac{3}{8}$ -inches wide by $\frac{11}{16}$ -inches high; while support rod inner section **141** is made from aluminum and measures $\frac{5}{16}$ -inches wide by $\frac{19}{16}$ -inches high by 36-inches long (outside dimensions). Although a rectangular shape is shown for upper support rod **140**, other shapes, such as oval shapes, may be used. FIG. 28B shows an alternate upper backdrop support rod **143** consisting of a circular rod inner section **144** and a circular rod outer section **145**. Circular rod inner section **144** is formed in such a way as to move in and out of circular rod outer section **145** allowing alternate upper support rod **143** to be made variable in length. In the current embodiment, circular rod outer section **145** is an aluminum tube with a $\frac{3}{4}$ -inch outside diameter, a $\frac{23}{32}$ -inch inside diameter, and is 36-inches long, while circular rod inner section **144** is an aluminum tube with a $\frac{11}{16}$ -inch outside diameter, a $\frac{21}{32}$ -inch inside diameter, and is 36-inches long. Although a circular shape is shown for alternate upper support rod **143**, other shapes, such as oval shapes, may be used. FIG. 28C shows a fixed length support rod **147**, which is used to keep backdrop assembly **4** fixed in place while hanging from curved backdrop rod hanger **107** in the current embodiment, or fixed length support rod **147** may be used in backdrop assembly **4** as a fixed length upper support rod. In the current embodiment fixed length support rod **147** is a cylindrical tube, preferably made from aluminum, although other materials could be used, measuring $\frac{3}{4}$ -inches in diameter, with a $\frac{23}{32}$ -inch inside diameter, and is 48-inches long. Although a circular shape is shown for fixed length support rod **147**, other shapes, such as oval shapes, may be used. FIG. 28D shows an alternate fixed length support rod **148**, which can be used in backdrop assembly **4** to keep it

16

fixed in place while hanging from curved backdrop rod hanger **107** in the current embodiment, or alternate fixed length support rod **148** may be used in backdrop assembly **4** as a fixed length upper support rod. In the current embodiment alternate fixed length support rod **148** is a square tube, preferably made from aluminum, although other materials could be used, measuring $\frac{3}{4}$ -inches wide by $\frac{3}{4}$ -inches high, with an inside measurement of $\frac{23}{32}$ -inch width by $\frac{23}{32}$ -inch height, and is 48-inches long. Although a square shape is shown for alternate fixed length support rod **148**, other shapes, such as rectangular shapes, may be used. Although in the current embodiment, aluminum is the preferred material for rods **140**, **143**, **147**, and **148**, other materials, such as wood, plastic, steel, etc., can be used.

Note that although specific sizes of the components forming modular background set **1** have been discussed, those components can be constructed in different sizes to form a variety of configurations of modular background set **1**. Support base assembly **5**, base inner sleeve **30**, a plurality of outer column sleeves **50**, a plurality of inner column sleeves **70**, a plurality of inner sleeve support frames **80**, and column top cap **112** can all be adjusted in width, depth and height to form a column **3**, which is smaller or larger (in perimeter), or shorter or taller (in height). Column **3** height may also be adjusted using more or less of outer column sleeves **50**, inner column sleeves **70**, and inner sleeve support frames **80**. Backdrop assembly **4** can be adjusted in height and width, and when combined with various column **3** sizes, form shorter or taller modular background set **1**. That is, there are a number of modular background set **1** configurations that can be formed.

DETAILED DESCRIPTION

Method of Assembly—FIGS. 29-46

FIGS. 29 to 46 illustrate the method for assembly of modular background set **1**, which consists of a plurality of completed columns **3** and backdrop assembly **4**. FIGS. 29 to 43 illustrate the method of assembly of column **3**, which, in the current embodiment, consists of support base assembly **5**, base inner sleeve **30**, three outer column sleeves **50**, two inner column sleeves **70**, two inner sleeve support frames **80**, one column top cap **112**, one tension cable **130**, and a plurality of curved backdrop rod hangers **107**.

Turning now to FIG. 29, support base assembly **5** is initially placed on a solid surface **164**, with column wall attachment assembly **7** facing upward. Next, base inner sleeve **30** is manipulated to its expanded state; positioned with first instruction label **160** visible at the top of base inner sleeve **30**; and placed on support base assembly **5** by moving it in an installation direction **162** until it engages column support section **18**. Note that the bottom of tab attachment area **41** fits within support base attachment wall gap **19**.

Next, turning now to FIG. 30, base inner sleeve **30** is manipulated until base inner sleeve attachment apertures **44** align with support base fastener apertures **22**. A plurality of fasteners **166** are combined with a plurality of washers **167**, and then inserted through base inner sleeve attachment apertures **44**, and support base fastener apertures **22**. A nut fastener **168** is threadably engaged with each fastener **166** on the inside of column wall attachment assembly **7** until base inner sleeve **30** is securely attached to column wall attachment assembly **7** of support base assembly **5** (fastener **166** is preferably a #6-32, by $\frac{1}{2}$ -inch long machine screw, P/N 1488; washer **167** is preferably a #6 finishing washer, P/N 2923; and nut fastener **168** is preferably a wing nut, P/N 2685, all available from BoltDepot.com, North Weymouth, Mass.). Alter-

17

nately, when base fastener apertures **22** are threaded, fasteners **166** may be threadably engaged directly to wall attachment assembly **7**. Further, base inner sleeve **30** may be attached to wall attachment assembly **7** using quick release fasteners, such as the quick release ball lock pin from Fixtureworks in Michigan. That is, there are a number of fastener types that can be used to attach base inner sleeve **30** to wall attachment assembly **7**.

In the next step, as seen in FIGS. **31** and **32**, the first outer column sleeve **50** is manipulated to its expanded state; positioned with second instruction label **170** visible at the top of outer column sleeve **50**; placed over base inner sleeve **30**; and subsequently positioned on support base assembly **5** by moving it in installation direction **162** until it engages column support section **18**. As shown in FIG. **32**, with outer column sleeve **50** fully engaged, base inner sleeve **30** keeps outer column sleeve **50** from moving in directions orthogonal to installation direction **162**. Optionally, flute covering **106** can be installed at this point to cover flutes **90** of outer column sleeve **50**.

As seen in FIG. **33**, in the next step of assembly of column **3**, the first inner column sleeve **70** is manipulated to its expanded state; positioned with third instruction label **174** visible at the top of first inner column sleeve **70**; inserted within first outer column sleeve **50**; and subsequently positioned on a plurality of inner sleeve support shelves **64** by moving it in installation direction **162**.

As seen in FIGS. **34** and **35**, first inner column sleeve **70** is further supported and kept square by installing first inner sleeve support frame **80**. First inner sleeve support frame **80** is initially placed over first inner column sleeve **70** and then is moved in installation direction **162** until it engages the top of first outer column sleeve **50**. When the installation of first inner column sleeve **70** and first inner sleeve support frame **80** are completed, a portion of first inner column sleeve **70** remains exposed in order to accept second outer column sleeve **50** in the next step. Optionally, first outer column sleeve **50** may be further supported by connecting it to optional first outer column support bracket **85**, and thus indirectly to first inner sleeve support frame **80**, using a plurality of outer column sleeve fasteners **88** and washers **167** (such as a #6-32, by 1/2-inch long machine screw coupled with a #6 finishing washer, P/N 2923, available from BoltDepot.com, North Weymouth, Mass.), which engage a plurality of threaded support bracket apertures **87**. Additionally, first outer column sleeve **50** may be connected to optional first outer column support bracket **85** using quick release fasteners, such as the quick release ball lock pin from Fixtureworks in Michigan. That is, there are a number of fastener types that can be used to attach first outer column sleeve **50** to optional first outer column support bracket **85**. Even further, as seen in FIG. **35**, to optionally provide further alignment of first outer column sleeve **50**, a plurality of circular outer sleeve alignment rods **100**, or rectangular outer sleeve alignment rods **104**, could be installed at this point through alignment dowel apertures **82** and into flutes **90** at the top of first outer column sleeve **50**.

As seen in FIG. **35**, the next outer column sleeve **50**, which is the second outer column sleeve in the current embodiment, is manipulated to its expanded state; positioned with second instruction label **170** visible at the top of second outer column sleeve **50**; placed over first inner column sleeve **70**; and subsequently positioned on first inner sleeve support frame **80** by moving it in installation direction **162** until it engages first inner sleeve support frame **80**. With second outer column sleeve **50** fully engaged to first inner sleeve support frame **80**, first inner column sleeve **70** keeps second outer column sleeve

18

50 from moving in directions orthogonal to installation direction **162**. If desired, flute covering **106** can be installed at this point to cover flutes **90** at both the bottom and top of second outer column sleeve **50**. Optionally, if installed in an earlier step, second outer column sleeve **50** may be further supported by connecting it to optional first outer column support bracket **85**, and thus indirectly to first inner sleeve support frame **80**, using a plurality of outer column sleeve fasteners **88** and washers **167**. Further, if optionally installed in an earlier step, a plurality of outer sleeve alignment rods **100** (**104**) extending from first outer column **50** could engage a plurality of flutes **90** located at the bottom of second outer column sleeve **50**.

Turning now to FIG. **36A**, prior to installing the second, and final inner column sleeve **70** in the current embodiment, and the third and final outer column sleeve **50** in the current embodiment (both described just below in the Specification), a plurality of curved backdrop rod hangers **107** are installed into column top cap **112**. To accomplish this installation, straight shaft **110** of each curved backdrop rod hangers **107** is inserted into backdrop rod hanger apertures **114**. In the current embodiment, two curved backdrop rod hangers **107** are installed in the backdrop rod hanger apertures **114** located closest to the inside of constructed column **3** (where backdrop assembly **4** will be placed). Next, one end of tension cable **130** is placed within upper tension cable slot **127**. The opposite end of tension cable **130** is then placed through the top opening of third outer column sleeve **50** so that it protrudes through the bottom of third outer column sleeve **50**. Column top cap **112** is then inserted into third outer column sleeve **50** by moving it in installation direction **162** until it engages the top of third outer column sleeve **50**.

Optionally, in an alternate embodiment, as shown in FIG. **36B**, second column top cap **129** may be used. In this alternate embodiment, two curved backdrop rod hangers **107** are installed into third outer column sleeve **50** by inserting straight shaft **110** of each curved backdrop rod hanger **107** into a top flute **90** located closest to the inside of constructed column **3** (where backdrop assembly **4** will be placed). Next, one end of elastic cable **139** is threaded through column top cable aperture **190** and then through endpiece **131**, where the end of elastic cable **139** is tied into a knot so as not to pull through the 1/4-inch hole in endpiece **131**. The opposite end of tension cable **130** is then placed through the top opening of third outer column sleeve **50** and pulled downward in installation direction **162** until endpiece **131** engages the top of second column top cap **129**. The opposite end of tension cable **130** now protrudes through the bottom of third outer column sleeve **50**. Second column top cap **129** is then inserted into third outer column sleeve **50** by moving it in installation direction **162** until it engages a plurality of support shelves **64**.

Alternately, although not directly shown, third column top cap **156** could be used at this point in the installation procedure (FIGS. **26D** and **26E** show third column top cap **156** in position to install onto to outer column **50**). In this optional embodiment, two curved backdrop rod hangers **107** are installed in the backdrop rod hanger apertures **114** located closest to the inside of constructed column **3** (where backdrop assembly **4** will be placed). Next, one end of tension cable **130** is placed within upper tension cable slot **127**. The opposite end of tension cable **130** is then placed through the top opening of third outer column sleeve **50** so that it protrudes through the bottom of third outer column sleeve **50**. Third column top cap **156** is then inserted into the third outer column sleeve **50** by moving it in installation direction **162** until it engages the top of third outer column sleeve **50**.

Optionally, column top cap **112** and third column top cap **156** can be attached to final outer column **50** using a plurality

of fasteners 166 and washers 167. FIGS. 26D and 26E, show this optional attachment using third column top cap 156, although the identical procedure can be used for column top cap 112. Once third column top cap 156 is inserted into final outer column 50, fasteners 166 (coupled with washers 167) are inserted through a plurality of outer column sleeve upper attachment apertures 122 and are threadably engaged with a plurality of threaded column top cap fastener apertures 120 in third column top cap 156.

FIG. 37 describes the next step in the assembly of column 3. In this step second and final inner column sleeve 70 is first inserted into second outer column sleeve 50 (as described above in FIG. 33). Next, second and final sleeve support frame 80 is installed onto second inner column sleeve 70 (as described above in FIG. 34). If optionally used, optional second outer column support bracket 85, and a plurality of optional outer sleeve alignment rods 100 (104), can be installed at this point. Finally, third and final outer column sleeve 50, assembled with column top cap 112 (or optionally third column top cap 156), as described above in FIG. 36A in this embodiment, with curved backdrop rod hangers 107 and tension cable 130 already installed, is placed over second and final inner column sleeve 70 (as described in FIG. 35). Note that tension cable 130 now protrudes through all column 3 components below third and final outer column sleeve 50. If desired, flute covering 106 can be installed at this point to cover flutes 90 at both the bottom and top of third and final outer column sleeve 50. Optionally, if optional second outer column support bracket 85 was installed in an earlier step, second and third outer column sleeves 50 may be further supported by connecting them to optional second outer column support bracket 85, and thus indirectly to second inner sleeve support frame 80, using a plurality of outer column sleeve fasteners 88 and washers 167. Further, if optionally installed in an earlier step, a plurality of outer sleeve alignment rods 100 (104), extending from second outer column 50 could engage a plurality of flutes 90 located at the bottom of third outer column 50.

FIG. 38 shows the installation of alternate second column top cap 129, assembled with third and final outer column sleeve 50 (as described in FIG. 36B). This alternate combination is then installed as just described above in the embodiment shown in FIG. 37, along with any optional components, such as flute covering 106, outer column support bracket 85, or outer sleeve alignment rods 100 (104).

FIG. 39 shows an overall perspective view of the steps just described above in FIGS. 29 to 38, including possible optional embodiments (such as outer column support brackets 85 and outer sleeve alignment rods 100 (104)). Note also that in an alternate installation approach, any of top caps 112, 129, or 156 may be installed onto final outer column sleeve 50 after final outer column sleeve 50 has been installed onto second and final inner column sleeve 70.

Turning now to FIG. 40, the last step in the construction of column 3 involves the final installation of tension cable 130. As seen in FIGS. 36A and 37, tension cable 130 is now protruding through all column 3 components below third and final outer column sleeve 50. To complete column 3 assembly, the user places their hand through outer sleeve access aperture 66 and base inner sleeve access aperture 49 to grasp the other endpiece 131 of tension cable 130. Once endpiece 131 is in hand, it is pulled in a downward installation direction 162 and placed in lower tension cable slot 27, thus placing all components in column 3 in vertical tension.

FIGS. 41A and 41B show two completed columns 3. FIG. 41A describes the completed column 3 of this embodiment. FIG. 41B shows an alternate embodiment using third column

top cap 156 and alternate inner sleeve support frame 74 where support frame shelf 78 may be used as an additional surface area for placing supplementary items used in tradeshow, broadcast television studios, etc., such as brochures, display monitors, and speakers, to name a few.

FIG. 42 shows the use of additional embodiments of tension cables 132, 134, and 136. Alternate tension cable 132 attaches to column top cap 112 using upper tension cable slot 127 at the top of column 3, and to support base assembly 5 using lower tension cable slot 27 at the bottom of column 3. FIG. 42 also shows the use of additional tension cable 134, and adjustable tension cable 136, whose ends are attached to upper tension hook 128, which is engaged with column top cap 112 at the top of column 3, and attached to lower tension hook 25, which is engaged with support base assembly 5, at the bottom of column 3. FIG. 43 shows the use of second column top cap 129 with alternate tension cable 132, and alternate rectangular backdrop rod hangers 108, in an alternate embodiment of column 3. Note also that although tension cable 130, or additional embodiments of tension cables 132, 134, and 136, is used in this embodiment, column 3 may be assembled without a tension cable, while still functioning as designed.

Note also that due to the lightweight design of this embodiment, at any time during the assembly of column 3, the partially-assembled column may be tilted forward or backward, or to the left or right, in order to attach column 3 components, thereby eliminating the need for additional hardware, such as ladders. Footpad section 16 may also be used in the manipulation of column 3.

Optionally, the assembly of column 3 can be implemented by placing support base assembly 5 on its side, with column wall attachment assembly 7 facing parallel to solid surface 164. Assembly of column 3 would continue as just described above but with all components installed in a horizontal direction. Once assembled, column 3 would be positioned vertically to complete the assembly.

Once columns 3 have been assembled, backdrop assembly 4 may be attached. Turning now to FIG. 44, backdrop assembly 4 is comprised of two support rods 140, one for upper support and one for lower support, and a backdrop 150, which possesses a display surface 151. In the current embodiment, backdrop 150 is a canvas fabric material, available from Genesis Art Supplies, of Chicago, Ill., although other fabric materials such as nylon, cotton, polyester/cotton blend, etc., can be used. In its final form, backdrop 150 measures 48-inches wide by 95-inches high. Backdrop 150 may be of a single color or multiple colors; display images (such as company logos) or text; or be used as a video projection screen; that is, backdrop 150 is capable of providing many variations of backgrounds suited for a variety of settings and uses. Backdrop assembly 4 is formed by inserting a first support rod 140 into a backdrop upper rod sleeve opening 152 until both ends of first support rod 140 are seen protruding from the ends of backdrop upper rod sleeve opening 152, and inserting a second support rod 140 into a backdrop lower rod sleeve opening 154 until both ends of second support rod 140 are seen protruding from the ends of backdrop lower rod sleeve opening 154.

Turning now to FIG. 45, backdrop assembly 4 is attached to a set of completed columns 3 by inserting support rod inner section 141 into a pair of curved backdrop rod hangers 107 installed on a first column 3, and subsequently inserting support rod outer section 142 into a pair of curved backdrop rod hangers 107 installed on a second column 3, such that display surface 151 of backdrop 150 is facing in a forward direction 180. Backdrop 150 is then allowed to hang between the set of columns 3, while held in place by the weight of second

21

support rod **140**, located at the bottom of backdrop **150**, whose ends fit within cutout slots **17** of support base assembly **5** (see FIG. 2F).

FIG. **46** shows an alternate embodiment using alternate support rod **143** and second column top cap **129**. In this embodiment circular rod inner section **144** is inserted into a pair of curved backdrop rod hangers **107** installed on a first column **3**, and circular rod outer section **145** is inserted into a pair of curved backdrop rod hangers **107** installed on a second column **3**, such that display surface **151** of backdrop **150** is facing in a forward direction **180**. Backdrop **150** is then allowed to hang between the set of columns **3**, while held in place by the weight of alternate support rod **143**, or alternately, support rods **147** or **148**, whose ends fit within cutout slots **17** of support base assembly **5**.

The final, completed assembly of this embodiment of modular background set **1** is shown in FIG. **1**. Modular background set **1** can be readily and easily disassembled in the reverse order to that described above to a very compact and lightweight configuration that may be easily transported in small boxes, suitcases, or other enclosures, as described above.

DETAILED DESCRIPTION AND METHOD OF ASSEMBLY

Alternate Embodiment—FIG. 41A or 41B

In another embodiment, using FIG. **41A** or **41B**, a modular background set **1**, featuring a single column, can be produced by placing backdrop rod hangers (**107**, **108**) at the front of completed column **3** in either flutes **90**, or backdrop rod hanger apertures **114**, if column top cap one **112** or third column top cap **156** are used. Support rod **140** and display surface **151** maintain similar structure as described above, but may be adjusted in size to form the single column display configuration. In this configuration, backdrop **150** will be positioned in front of column **3**. Modular background set **1**, configured in a single column, can be readily and easily disassembled in the reverse order to that described above to a very compact and lightweight configuration that may be easily transported in small boxes, suitcases, or other enclosures, as described above.

DETAILED DESCRIPTION AND METHOD OF ASSEMBLY

Additional Embodiment—FIG. 32

In another embodiment, described in FIG. **32**, a shortened modular background set **1** can be created by combining support base assembly **5**, base inner sleeve **30**, and outer column sleeve **50**. At this step, as described above, any of top caps **112**, **129**, or **156** may be installed onto final outer column sleeve **50**, with backdrop rod hangers (**107**, **108**) placed in either flutes **90**, or backdrop rod hanger apertures **114**, if column top cap one **112** or third column top cap **156** are used, thus completing column **3**. Support rod **140** and display surface **151** maintain similar structure as described above, but may be adjusted in size to the required height and width to fit between two shortened columns **3**. Shortened modular background set **1** can be readily and easily disassembled in the reverse order to that described above to a very compact and lightweight configuration that may be easily transported in small boxes, suitcases, or other enclosures, as described above.

22

DETAILED DESCRIPTION AND METHOD OF ASSEMBLY

Further Alternate Embodiments—FIGS. 47-50

In another embodiment, shown in FIG. **47**, four completed columns **3** are combined with three backdrop assemblies **4** to create a background with non-orthogonal wings, which are commonly used in tradeshows, broadcast television, or theatre. In this embodiment, all four columns **3** are assembled as described above in FIGS. **29** to **46**. To accomplish the wing-assembly configuration, the two center columns **3** use two column top caps **112**, each with two curved backdrop rod hangers **107** installed within backdrop rod hanger apertures **114** positioned along top cap angle **119** (see FIGS. **24A** and **25C**). The outer columns **3** use two column top caps **112**, each with two curved backdrop rod hangers **107** installed within backdrop rod hanger apertures **114** positioned along the backside of column top cap **112** (as seen in FIG. **25A**). In the current embodiment, when the two side backdrop assemblies **4** are installed in this manner, a 45-degree orientation direction **194** is formed, thus creating the non-orthogonal wing configuration.

In yet another embodiment, shown in FIG. **48**, four columns **3** are combined with three backdrop assemblies **4** to create a background with orthogonal wings, commonly used in tradeshows, broadcast television, or theatre. In this embodiment, all four columns **3** are assembled as described above in FIGS. **29** to **46**, but with second column top cap **129** used in order to demonstrate the flexibility of this embodiment. To accomplish the orthogonal wing-assembly configuration, the two center columns **3** use second column top caps **129**, each with two additional curved backdrop rod hangers **107** inserted directly into corrugated plastic sheet flutes **90** positioned along the outside edge of outer column sleeves **50**. The two outer columns **3** use second column top caps **129**, each with two curved backdrop rod hangers **107** inserted directly into corrugated plastic sheet flutes **90** positioned along the backside edge of outer column sleeves **50** (as seen in FIG. **26B**). In the current embodiment, when the two side backdrop assemblies **4** are installed in this manner, a 90-degree orientation direction **196** is formed, thus creating the orthogonal wing configuration.

As discussed in the description of the construction of column top cap **112** in FIGS. **22** to **25**, top cap angle **119** could be machined to other angles to form different background wing-assembly configurations.

DETAILED DESCRIPTION

Further Additional Embodiment—FIG. 49

In an additional embodiment, shown in FIG. **49**, lintel **200** is constructed from a lintel column **201** and a plurality of lintel end caps **202**. Lintel column **201** is further formed from a plurality of inner column sleeves **70**; inner sleeve support frames **80**; and outer column sleeves **50**, each with the same shape, but with different dimensions than those used in the assembly of column **3**, and formed in a manner similar to the components of column **3**, as described above in FIGS. **4A** to **4E** and FIGS. **8A** to **8E**. In the current embodiment, inner column sleeve **70** for lintel column **201** measures 6.3-inches wide by 6.5 inches deep by 13-inches long (outside dimensions); inner sleeve support frame **80** for lintel column **201** measures 7.0-inches wide by 7.2 inches deep by ½-inches long (outside dimensions), with an internal cutout **81** measuring 6.4-inches wide by 6.6 inches deep, allowing it to fit

around inner column sleeve **70**; and outer column sleeve **50** for lintel column **201** measures 6.8-inches wide by 7.0 inches deep by 26.5-inches long (outside dimensions). Lintel end cap **202** is preferably made from a closed cell polymerized vinyl chloride (PVC) material, such as Sintra®, which is lightweight with a high-stiffness; is available in a variety of thicknesses and colors; and can be cut, milled, routed or drilled to form many shapes. Note that other stiff, lightweight materials could be used, such as cellular utility polymer sheet material (e.g., King StarLite® XL); acetal plastics (e.g., Delrin®); and Polyamide (Nylon); to name a few. For this embodiment lintel end cap **202** is constructed from ½-inch (13-mm) thick Sintra® in a black color, although other thicknesses and colors may be used. In the present embodiment, embodiment lintel end cap **202** has a cap inner section **204** measuring 6.2-inches wide by 6.4 inches deep by ¼-inches long (outside dimensions), and an end cap outer section **206** measuring 6.8-inches wide by 7.0 inches long by ¼-inch deep.

METHOD OF ASSEMBLY

Further Additional Embodiment—FIGS. 49-50

Since lintel **200** is constructed with similar components as used for column **3**, the assembly of lintel **200** is similar to the assembly of column **3**. That is, lintel **200** components inner column sleeves **70**, inner sleeve support frames **80**, and outer column sleeves **50**, are assembled as described above in FIGS. **33** to **35**. Once these components are assembled, lintel end caps **202** are installed on both ends of lintel **200**. As shown in FIG. **49**, cap inner section **204** frictionally fits within outer column sleeve **50** on each end of lintel column **201**. Once the assembly of lintel **200** is completed, it is attached to a set of columns **3**. To accomplish this each end of lintel **200** is placed upon a separate column top cap **112** before column top cap **112** is engaged with the top outer column sleeve **50** of a column **3**. A plurality of lintel column attachment apertures **203** are aligned with outer member lintel attachment apertures **116** and inner member lintel attachment apertures **117** on column top cap **112**. Once aligned, a plurality of fasteners **166**, washers **167**, and nut fasteners **168** are used to attach lintel **200** to each column top cap **112** (fasteners **166**, washer **167**, and nut fastener **168** are used in a similar method as shown before in FIG. **30**). Additionally, lintel **200** can be attached to each column top cap **112** using quick release fasteners, such as the quick release ball lock pin from Fixtureworks in Michigan. That is, there are a number of fastener types that can be used to attach lintel **200** to each column top cap **112**. Once lintel **200** is attached to column top caps **112**, the entire assembly is engaged with the top outer column sleeves **50** of each column **3**. If used, installation of tension cables **130** for each column **3** are then implemented as described before in FIG. **40**. The final assembly of this additional embodiment is shown in FIG. **50**.

From the foregoing, it is apparent that the portable, easily-assembled, modular background set described above not only provides for the reliable accomplishment of the purpose of this embodiment, but does so in a particularly simple, quick and reliable manner. It is recognized, of course, that those skilled in the art may make various modifications or additions to the embodiments chosen to illustrate the invention without departing from the spirit and scope of the present contribution to the art. Accordingly, it is to be understood that the protection sought and to be afforded hereby should be deemed to extend to the subject matter claimed and all equivalents thereof within the scope of the invention.

What is claimed is:

1. A modular configurable background set system comprising:
 - a plurality of columns, each said column comprising:
 - a plurality of inner sleeves, said inner sleeves are rectangular in shape comprising a plurality of corners, each said corner having a bend facilitated by a score line applied to the surface of said inner sleeve, said bends allowing said inner rectangular sleeves to be reversibly configured between an initial almost flat collapsed state to a rectangular shape state;
 - a base with structure for removably attaching to one of said inner rectangular sleeves;
 - a plurality of outer sleeves, said outer sleeves are rectangular in shape comprising a plurality of corners, each said corner having a bend facilitated by a score line applied to the surface of said outer sleeve, said bends allowing said outer sleeves to be reversibly configured between an initial almost flat collapsed state to a rectangular shape state;
 - at least one hanger member with structure for removably attaching to one of said outer rectangular sleeves; and
 - at least one backdrop system, said backdrop system comprising:
 - a display surface with a plurality of first openings formed therein; and
 - at least one backdrop support rod having a pair of opposing ends, said backdrop support rod removably inserted through one of said plurality of first openings, said one of each opposing ends of said backdrop support rod attaches to said at least one hanger member attached to said outer rectangular sleeve on a respective one of said columns thereby connecting said backdrop system between at least two said columns to form said background set system.
 2. The system of claim 1, wherein said plurality of inner rectangular sleeves are constructed from corrugated plastic sheets.
 3. The system of claim 1, wherein said plurality of inner rectangular sleeves have outside circumferential dimensions sized to frictionally fit within said plurality of outer rectangular sleeves.
 4. The system of claim 1, wherein said base includes a plurality of walls, said walls receiving a respective one of said inner rectangular sleeves, such that said respective one of said inner rectangular sleeves is held in a substantially orthogonal orientation relative to said base.
 5. The system of claim 4, wherein said walls include a plurality of threaded apertures to receive a plurality of removable fasteners such that said respective one of said inner rectangular sleeves is secured to said walls.
 6. The system of claim 1, wherein said plurality of outer rectangular sleeves are constructed from corrugated plastic sheets.
 7. The system of claim 1, wherein said plurality of outer rectangular sleeves have inside circumferential dimensions sized to frictionally fit around the outside of said plurality of inner rectangular sleeves.
 8. The system of claim 1, wherein said plurality of outer rectangular sleeves are configured to accept a top cap element.
 9. The system of claim 8, wherein said top cap element includes a plurality of apertures, said apertures configured to accept said at least one hanger member.

25

10. The system of claim 8, wherein said top cap element includes structure for accepting a tension cable, said tension cable used to keep said assembled column substantially aligned.

11. The system of claim 1, further comprising a plurality of support frames, each said support frame configured with a second opening sized to frictionally and removably engage with one of said plurality of inner rectangular sleeves such that said inner and outer rectangular sleeves are kept substantially square.

12. The system of claim 11, wherein said plurality of support frames are constructed from a closed cell polymerized vinyl chloride material.

13. The system of claim 11, wherein said plurality of support frames include a shelf.

14. The system of claim 1, further comprising a plurality of support rods, each support rod configured to attach to said inner rectangular sleeves such that said inner and outer rectangular sleeves are kept substantially square.

15. The system of claim 1, wherein said at least one hanger member is constructed from a rigid material, said rigid material is machinable, and said at least one hanger member is configured to accept said at least one backdrop support rod.

16. The system of claim 1, wherein said display surface is constructed from a fabric material.

17. The system of claim 1, wherein said plurality of first openings are located at opposite ends of said display surface.

18. The system of claim 1, wherein said at least one backdrop support rod is made from a rigid material, said rigid material is machinable, and said at least one backdrop support rod is configured to be adjustable in length.

19. The system of claim 1, wherein said at least one backdrop support rod is rectangular in shape.

20. The system of claim 1, wherein said at least one backdrop support rod is circular in shape.

21. A modular configurable background set system comprising:

a plurality of columns, each said column comprising:

a plurality of rectangular inner sleeves, each said rectangular inner sleeve comprising a plurality of corners, each said corner having a bend facilitated by a score line applied to the surface of said inner rectangular sleeve, said bends allowing said inner rectangular sleeves to be reversibly configured between an initial almost flat collapsed state to a rectangular shape state, each said rectangular inner sleeve having a pair of opposing ends, each said end configured with a first opening;

a base with structure for removably attaching to said first opening of one said end of one said rectangular inner sleeve;

a plurality of rectangular outer sleeves, each said rectangular outer sleeve comprising a plurality of corners, each said corner having a bend facilitated by a score line applied to the surface of said outer rectangular sleeve, said bends allowing said outer rectangular sleeves to be reversibly configured between an initial almost flat collapsed state to a rectangular shape state, each said rectangular outer sleeve having a pair of opposing ends, each said end configured with a second opening to frictionally and removably attach to one said end of one said rectangular inner sleeve;

a plurality of support frames, each said support frame configured with a third opening to frictionally and removably engage with one of said rectangular inner sleeves;

26

a top cap, said top cap includes structure for removably attaching to said second opening of one said end of one said rectangular outer sleeve, said top cap includes a plurality of apertures;

at least one hanger member, said hanger member configured to frictionally and removably attach to said plurality of apertures in said top cap; and
at least one backdrop system, comprising:

a backdrop, further comprising a display surface with a plurality of fourth openings formed therein, said fourth openings located at opposite ends of said display surface; and

at least one backdrop support rod having a pair of opposing ends, said backdrop support rod is adjustable in length and is removably inserted through one of said fourth openings,

said one of each opposing ends of said backdrop support rod attaches to at least one of said hanger members on a respective one of said plurality of columns thereby connecting said backdrop system between at least two of said plurality of columns to form said background set system.

22. A modular configurable background set system comprising:

at least one column, said column comprising:

at least one inner sleeve, said inner sleeve is rectangular in shape comprising a plurality of corners, each said corner having a bend facilitated by a score line applied to the surface of said inner sleeve, said bends allowing said inner rectangular sleeve to be reversibly configured between an initial almost flat collapsed state to a rectangular shape state, said inner sleeve having a pair of opposing ends, each said end configured with a first opening;

at least one base with structure for removably attaching to said first opening of one said end of said inner rectangular sleeve;

at least one outer sleeve, said outer sleeve is rectangular in shape comprising a plurality of corners, each said corner having a bend facilitated by a score line applied to the surface of said outer rectangular sleeve, said bends allowing said outer sleeve to be reversibly configured between an initial almost flat collapsed state to a rectangular shape state, said outer sleeve having a pair of opposing ends, each said end configured with a second opening to frictionally and removably attach to one said end of said inner sleeve;

a top cap, said top cap includes structure for removably attaching to said second opening of one said end of one said outer sleeve, said top cap includes a plurality of apertures;

a plurality of hanger members, each said hanger member configured to frictionally and removably attach to said plurality of apertures in said top cap; and

at least one backdrop system, comprising:

a backdrop, further comprising a display surface with a plurality of third openings formed therein, said third openings located at opposite ends of said display surface;

at least one backdrop support rod, said backdrop support rod removably inserted through one of said third openings,

said backdrop support rod attaches to said plurality of hanger members on said top cap of said at least one column thereby connecting said backdrop system to said at least one column to form said background set system.

23. A method for erecting a modular configurable background set in an area, said method comprising:

- (a) providing at least two columns, each of said columns comprising at least one inner rectangular sleeve and at least one outer rectangular sleeve, each said inner rectangular sleeve and said outer rectangular sleeve comprising a plurality of corners, respectively, each said corner of each said respective sleeve having a bend facilitated by a score line applied to the surface of each said respective sleeve, said bends allowing said respective inner and outer rectangular sleeves to be reversibly configured between an initial almost flat collapsed state to a rectangular shape state, each said sleeve expanded from a said almost flat collapsed state to said rectangular shape state, said inner and outer rectangular sleeves frictionally engaged together, said at least one frictionally engaged inner and outer rectangular sleeve structure removably attached to at least one base, and a plurality of hanger members removably attached to said at least one outer rectangular sleeve;
- (b) providing at least one backdrop system, said backdrop system comprising at least one display surface and at least one backdrop support rod removably attached to said display surface, said backdrop support rod having a pair of opposing ends;
- (c) connecting each respective said opposing end of said at least one backdrop support rod to a respective one of said plurality of hanger members attached to a respective one of said columns thereby connecting said backdrop system between at least two said columns, thereby forming said background set.

24. A method for erecting a modular configurable background set in an area, said method comprising:

- (a) providing at least two bases;
- (b) providing a plurality of inner sleeves, said inner sleeves are rectangular in shape comprising a plurality of corners, each said corner having a bend facilitated by a score line applied to the surface of said inner rectangular sleeve, said bends allowing said inner rectangular sleeves to be reversibly configured between an almost flat collapsed state to an expanded rectangular shape state, expanding a first said inner rectangular sleeve from said almost flat collapsed state to said expanded rectangular shape state, and removably attaching said expanded first inner rectangular sleeve to a respective one of said bases;
- (c) providing a plurality of outer sleeves, said outer sleeves are rectangular in shape comprising a plurality of corners, each said corner having a bend facilitated by a score line applied to the surface of said outer rectangular sleeve, said bends allowing said outer rectangular sleeves to be reversibly configured between an almost

flat collapsed state to an expanded rectangular shape state, expanding a first said outer rectangular sleeve from said almost flat collapsed state to said expanded rectangular shape state, and removably installing said expanded first outer rectangular sleeve onto a respective one of said expanded first inner rectangular sleeves until said expanded first outer rectangular sleeve engages a respective one of said bases;

- (d) expanding a second said inner rectangular sleeve from an almost flat collapsed state to an expanded rectangular shape state, and removably inserting said expanded second inner rectangular sleeve into a respective one of said expanded first outer rectangular sleeves;
 - (e) providing a plurality of support structures and removably installing a first said support structure onto a respective one of said expanded second inner rectangular sleeves until said first support structure engages a respective one of said expanded first outer rectangular sleeves;
 - (f) expanding a second said outer rectangular sleeve from an almost flat collapsed state to an expanded rectangular shape state, and removably installing said expanded second outer rectangular sleeve onto a respective one of said expanded second inner rectangular sleeves until said expanded second outer rectangular sleeve engages a respective one of said first support structures;
 - (g) repeating steps (a) through (f) for each respective one of said plurality of columns until the required height of a respective one of a said plurality of columns is achieved;
 - (h) providing a plurality of hanger members and attaching at least one of said hanger members to a respective one of said expanded final outer rectangular sleeves of a respective one of said plurality of columns;
 - (i) providing at least one backdrop system, said backdrop system comprising at least one display surface, said display surface comprising a plurality of first openings formed therein;
 - (j) providing at least one backdrop support rod, said backdrop support rod having a pair of opposing ends, and inserting said backdrop support rod through at least one of said plurality of first openings of said display surface; and
 - (k) connecting each respective said opposing end of said backdrop support rod to at least one of a respective said hanger member attached to a respective one of said expanded final outer rectangular sleeves thereby connecting said backdrop system between at least two said columns, thereby forming said background set.
25. The system of claim 4, wherein said base includes structure for accepting a tension cable, said tension cable used to keep said assembled column substantially aligned.