



US011906116B2

(12) **United States Patent**
Ernst et al.

(10) **Patent No.:** **US 11,906,116 B2**
(45) **Date of Patent:** **Feb. 20, 2024**

(54) **SOLID-STATE LIGHT EMITTER LIGHTING APPARATUS AND METHOD OF OPERATING THE SAME**

(58) **Field of Classification Search**
CPC . F21K 9/90; F21K 9/237; F21K 9/238; F21K 9/65; F21V 23/0471
See application file for complete search history.

(71) Applicant: **Astera Manufacturing Limited**, Shenzhen (CN)

(56) **References Cited**

(72) Inventors: **Norbert Ernst**, Shenzhen (CN); **Simon Canins**, Shenzhen (CN)

U.S. PATENT DOCUMENTS

(73) Assignee: **ASTERA MANUFACTURING LIMITED**, Shenzhen (CN)

11,272,599 B1 * 3/2022 Lewis H05B 45/12
2013/0009551 A1 * 1/2013 Knapp H05B 45/22
315/294
2016/0366746 A1 * 12/2016 van de Ven H05B 45/20
(Continued)

(*) Notice: Subject to any disclaimer, the term of this patent is extended or adjusted under 35 U.S.C. 154(b) by 0 days.

Primary Examiner — Elmito Breval
(74) *Attorney, Agent, or Firm* — Idea Intellectual Limited; Margaret A. Burke; Sam T. Yip

(21) Appl. No.: **18/323,431**

(57) **ABSTRACT**

(22) Filed: **May 25, 2023**

Provided are a solid-state lighting apparatus composed of a plurality of solid-state lighting units and a method of operating the same. Each solid-state lighting unit includes inter-unit communication modules, each module located on a corresponding side of the solid-state lighting unit and configured to communicate with an inter-unit communication module of a corresponding adjacent lighting unit connected to the lighting unit on the corresponding side. Each inter-unit communication module includes: a presence detector for detecting presence of the corresponding adjacent lighting unit; a presence indicator for indicating presence of a lighting unit to the corresponding adjacent lighting unit; an optical transceiver for communicating with corresponding optical transceivers in the corresponding adjacent lighting units. The solid-state lighting apparatus is operable to work in either a synchronous or a chain-effect mode. The invention allows flexible combination and convenient installation/rearrangement of lighting equipment to satisfy requirements for different lighting areas and working modes.

(65) **Prior Publication Data**

US 2023/0392758 A1 Dec. 7, 2023

(30) **Foreign Application Priority Data**

Jun. 1, 2022 (CN) 202221358295.6

(51) **Int. Cl.**

H05B 45/50 (2022.01)
F21K 9/90 (2016.01)
F21K 9/237 (2016.01)
F21V 23/04 (2006.01)
F21K 9/65 (2016.01)
F21K 9/238 (2016.01)

(52) **U.S. Cl.**

CPC **F21K 9/90** (2013.01); **F21K 9/237** (2016.08); **F21K 9/238** (2016.08); **F21K 9/65** (2016.08); **F21V 23/0471** (2013.01)

20 Claims, 22 Drawing Sheets

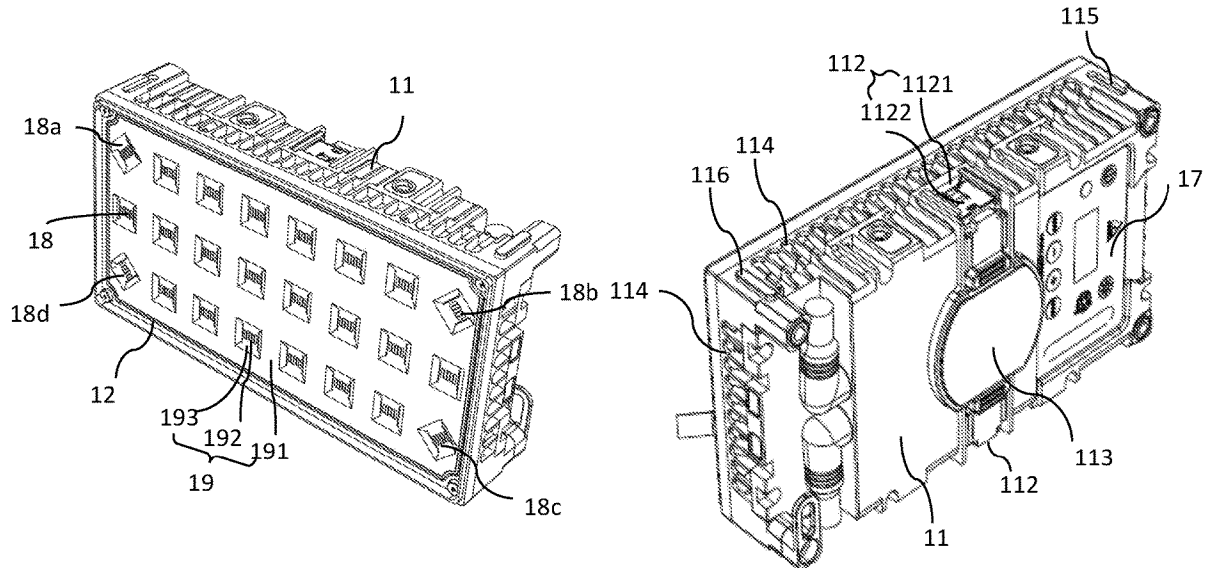

(56)

References Cited

U.S. PATENT DOCUMENTS

2017/0156189	A1*	6/2017	Jayawardena	H05B 47/105
2017/0359643	A1*	12/2017	Saha	F21V 31/005
2018/0073686	A1*	3/2018	Quilici	H05B 45/60

* cited by examiner

1A/1B

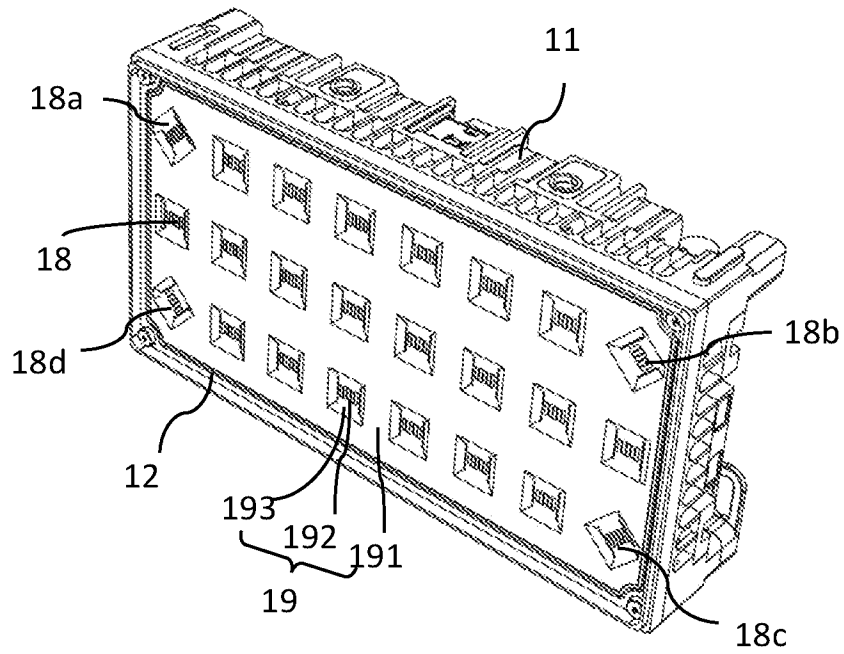

FIG. 1A

1A/1B

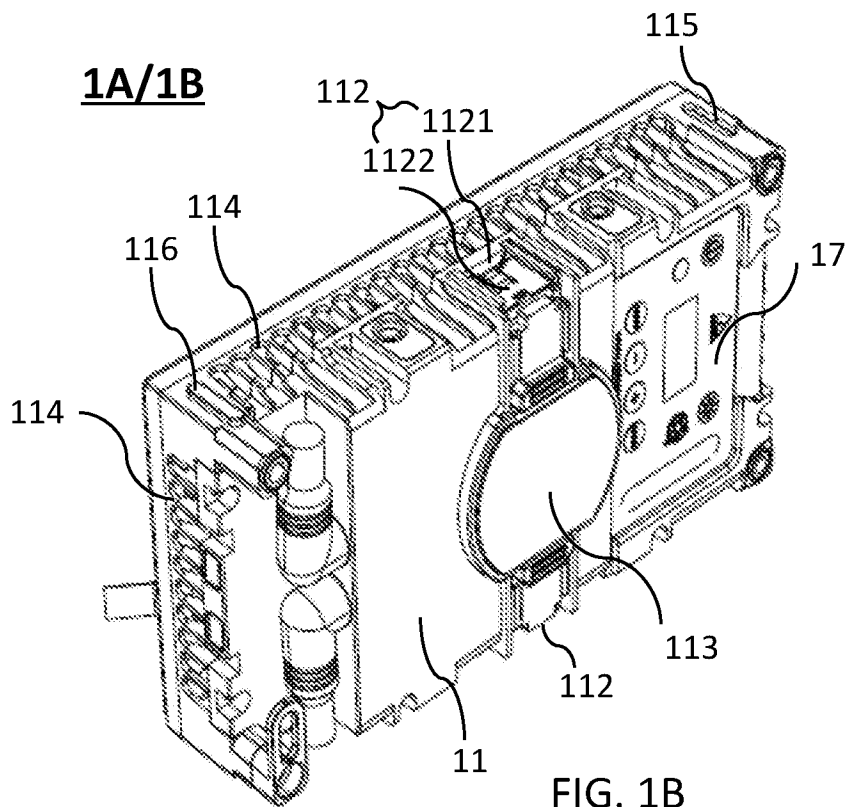

FIG. 1B

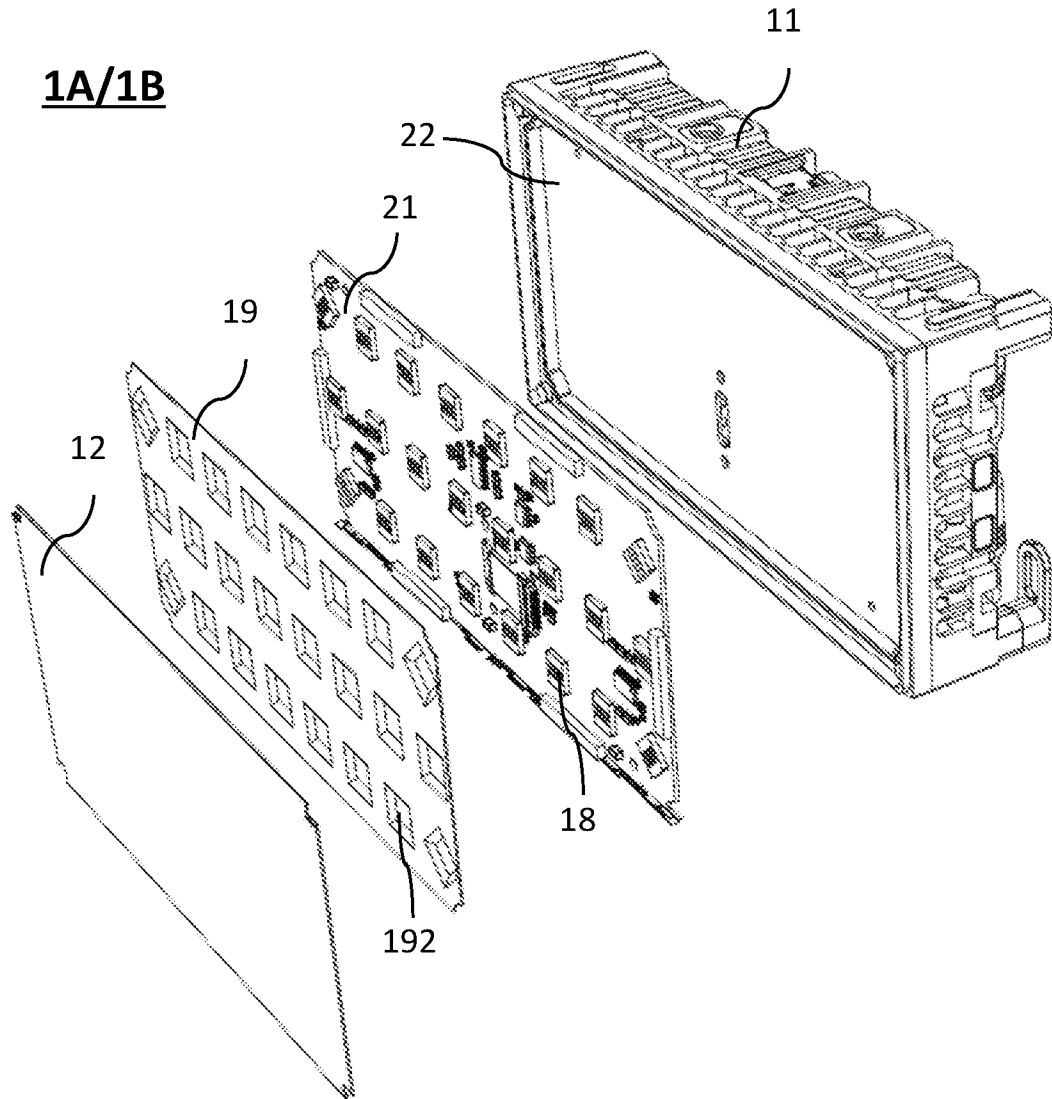

FIG. 1C

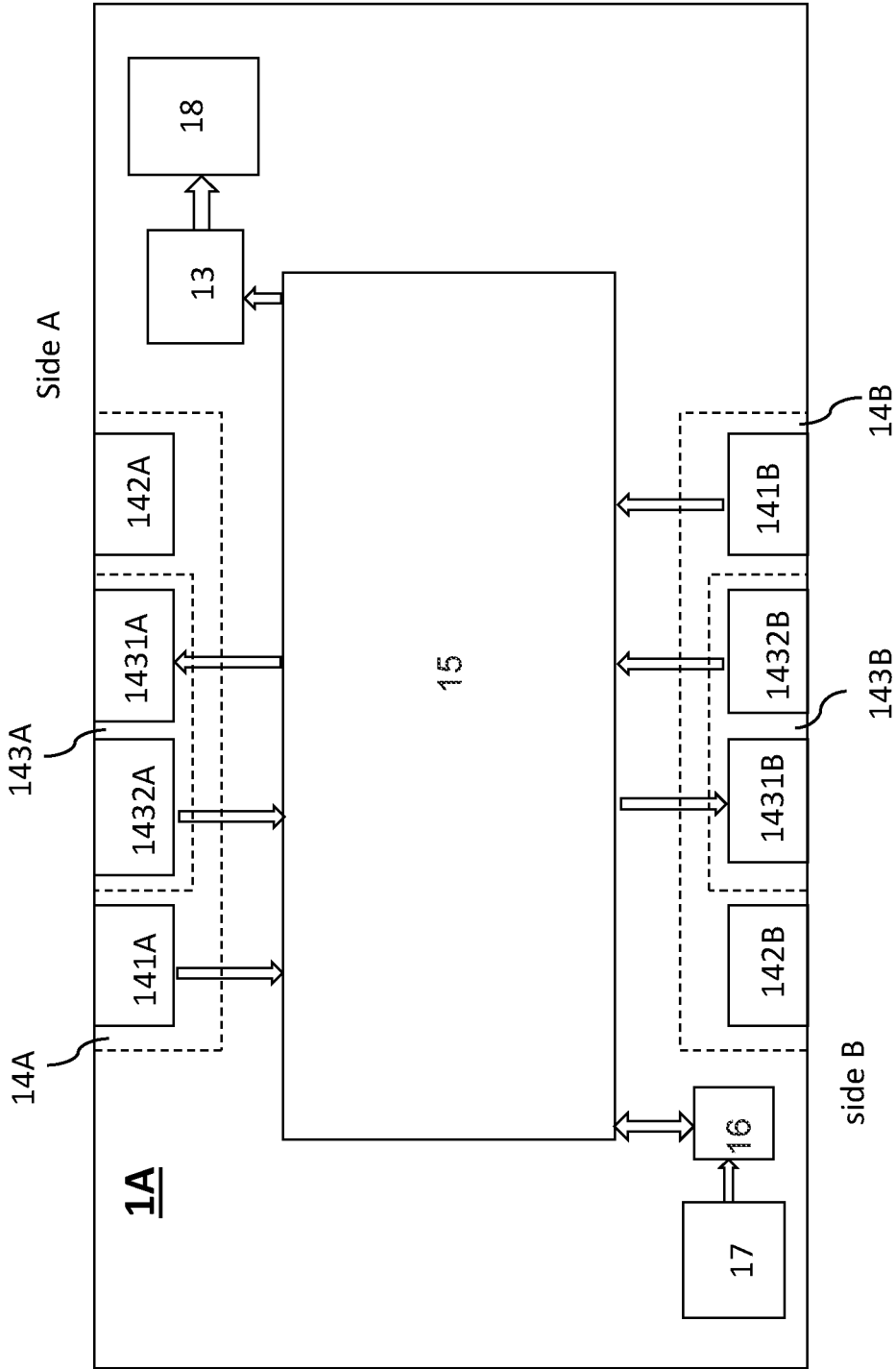

FIG.2A

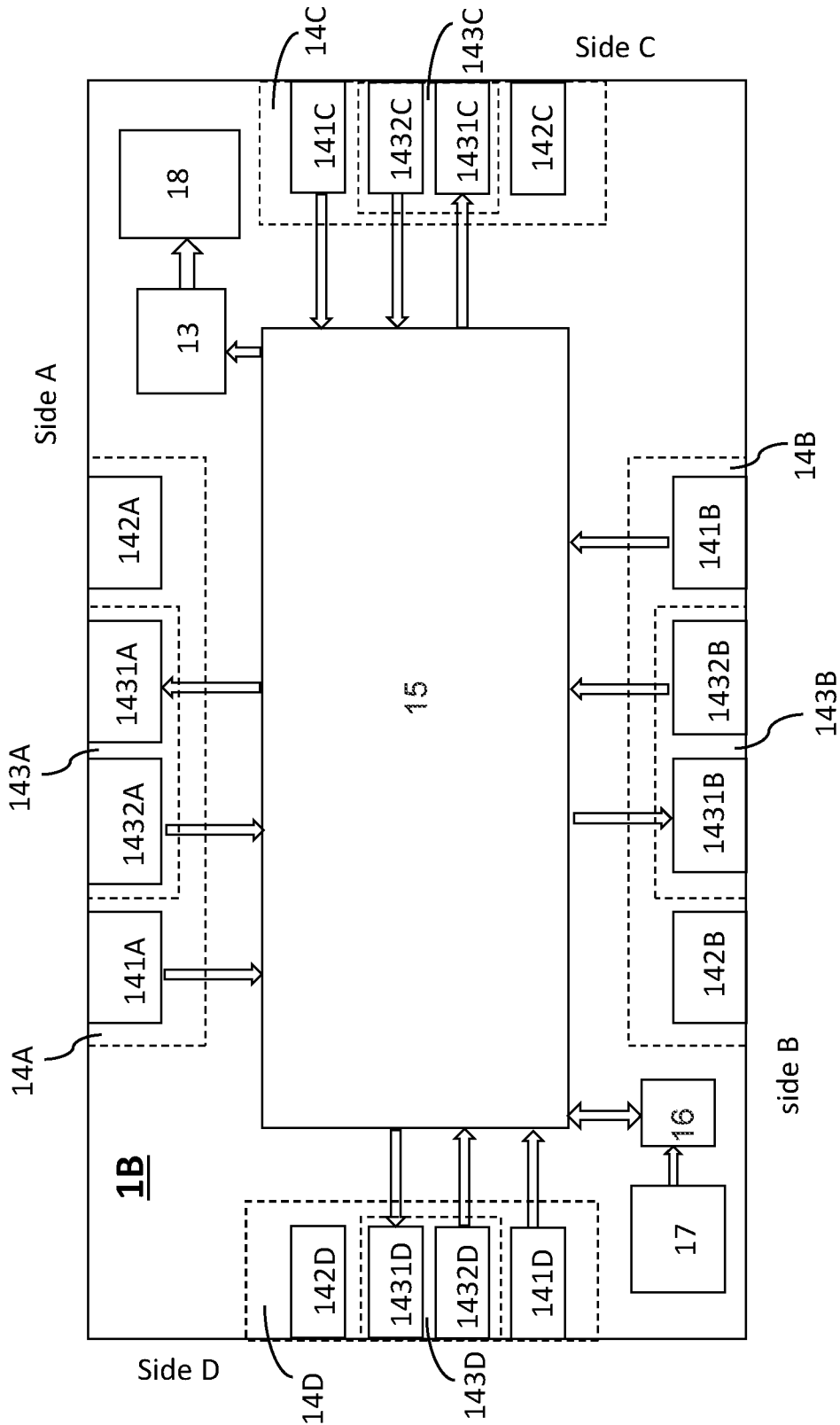

FIG.2B

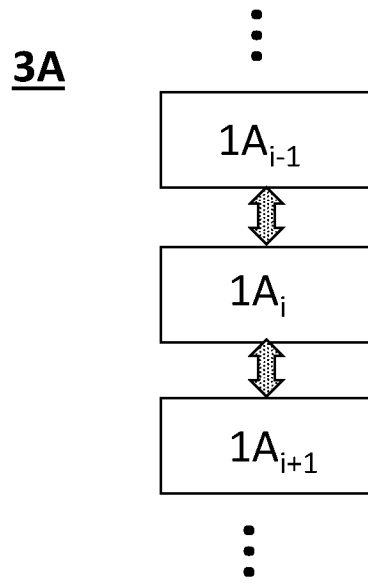

FIG. 3A

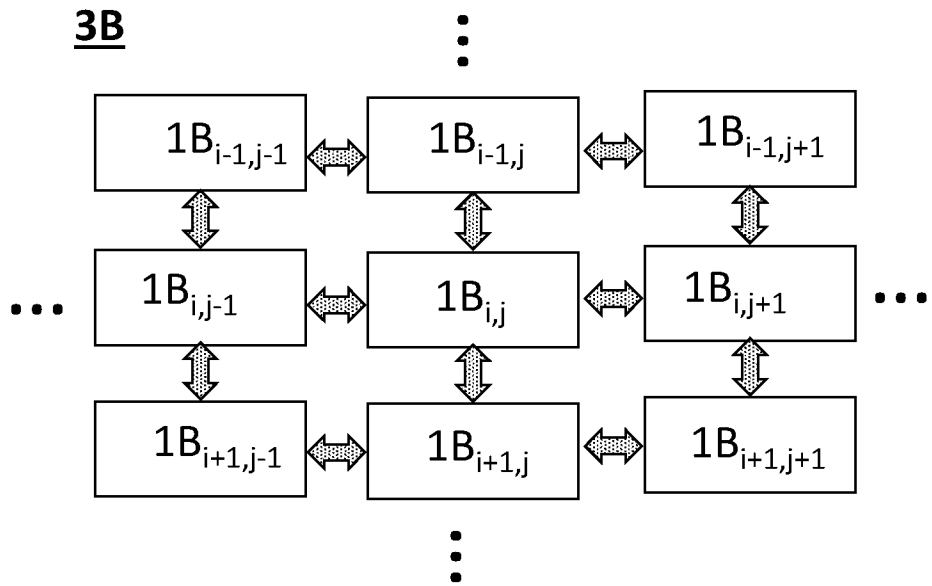

FIG. 3B

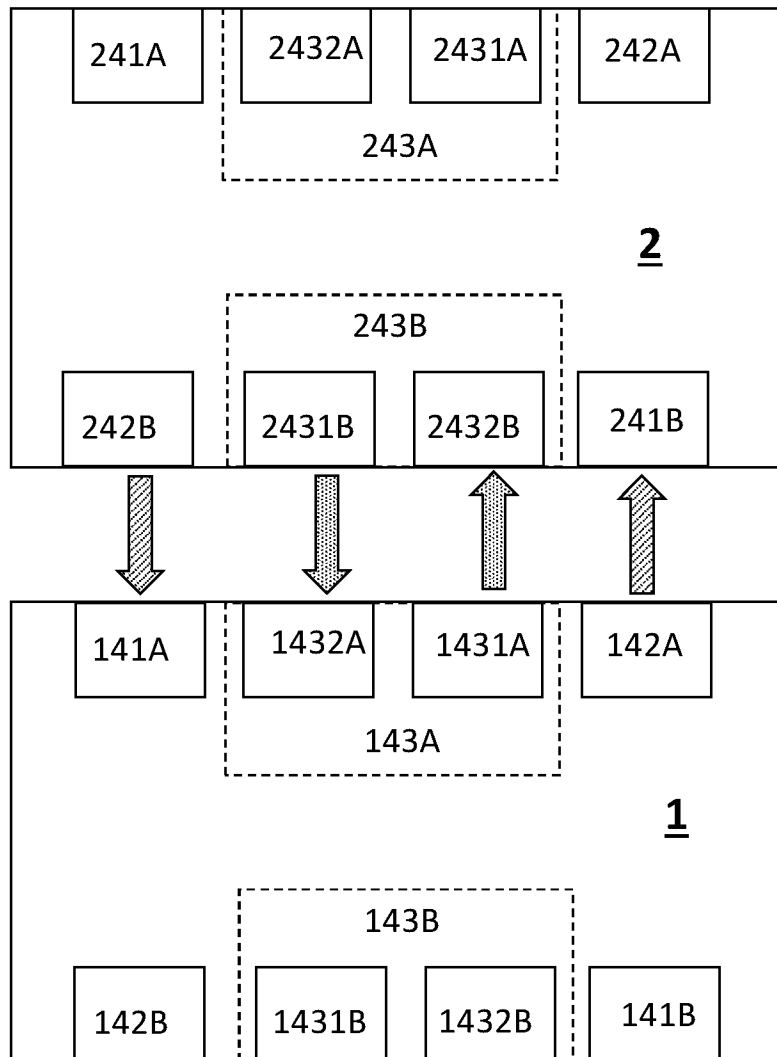

FIG. 4

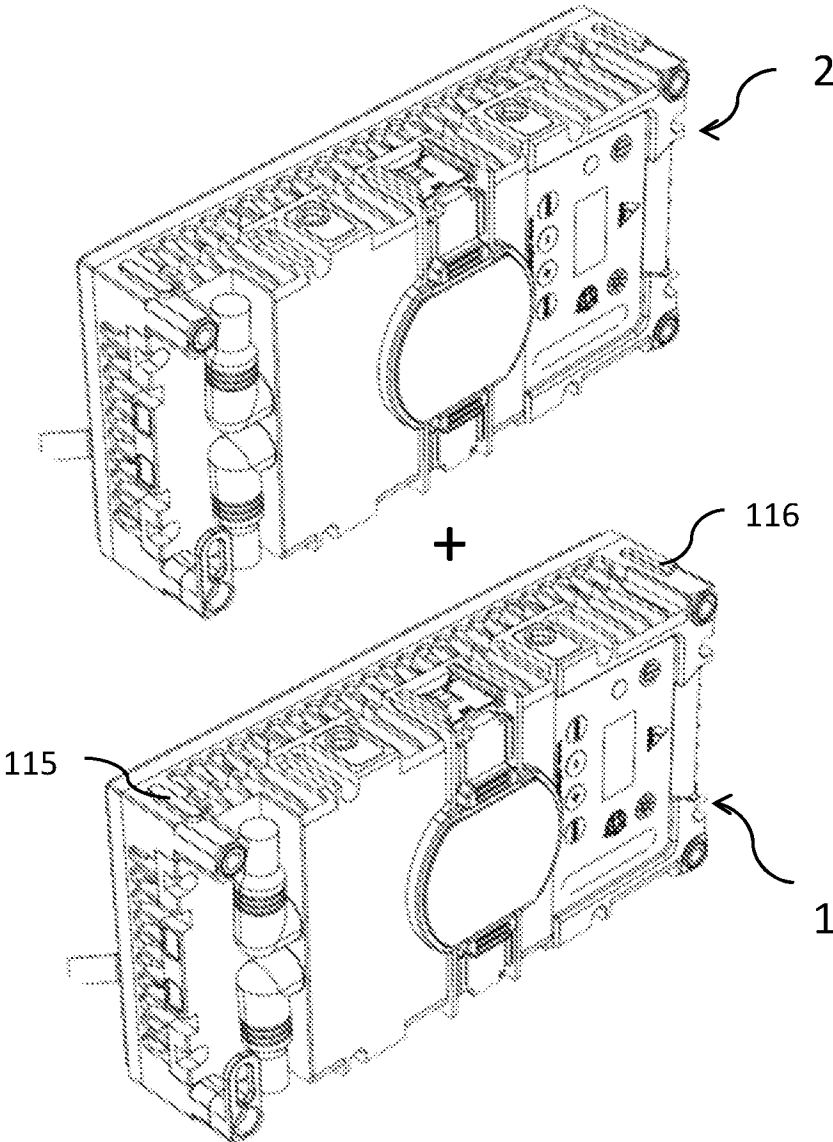

FIG. 5A

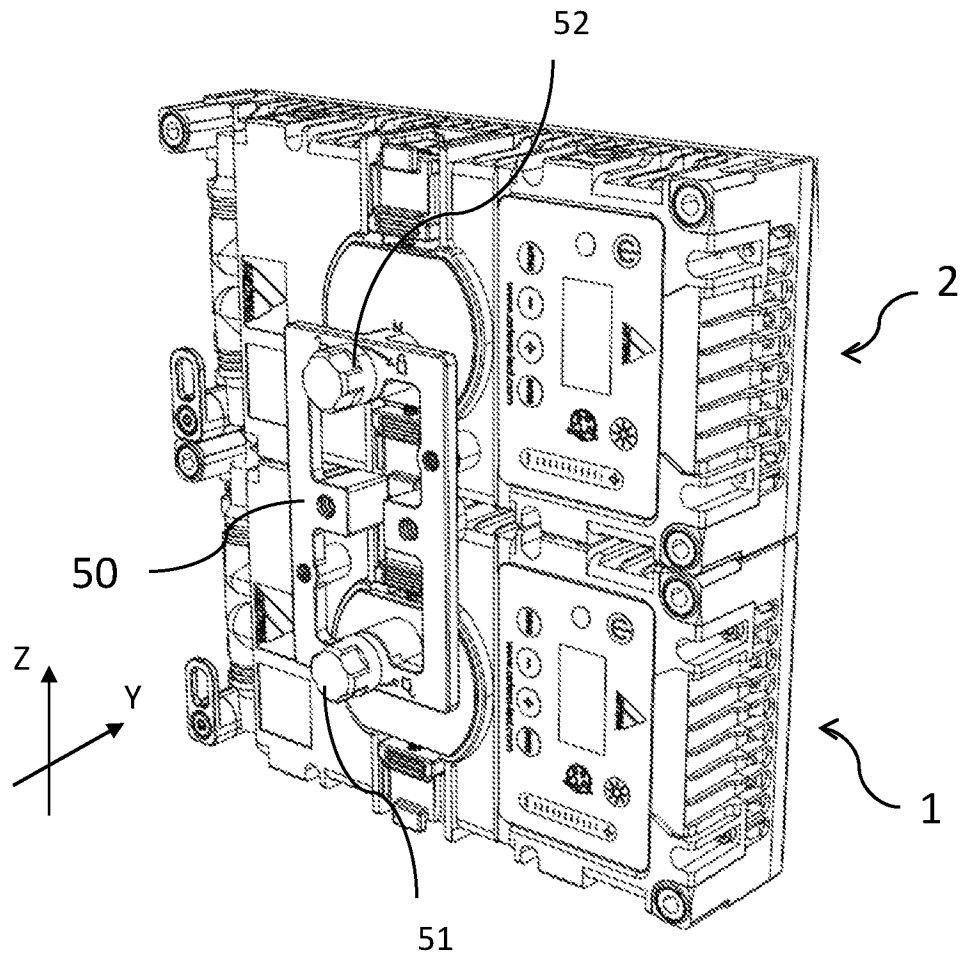

FIG. 5B

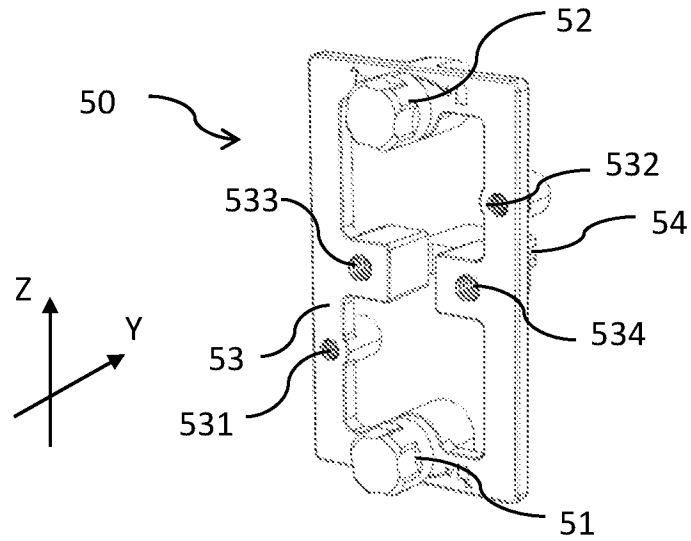

FIG. 6

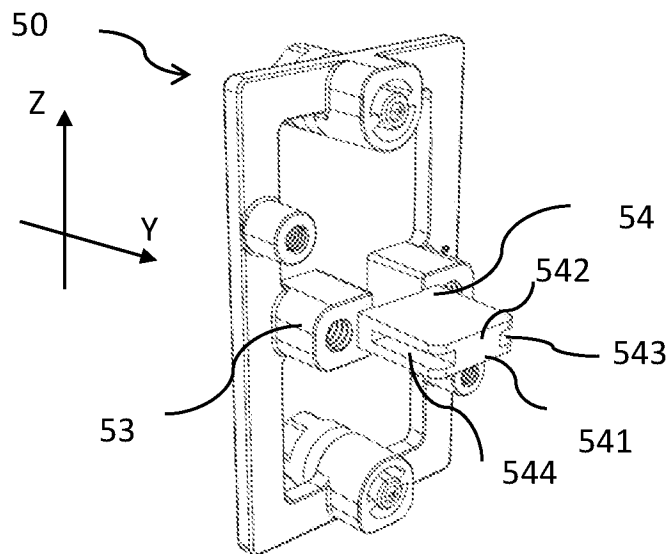

FIG. 7

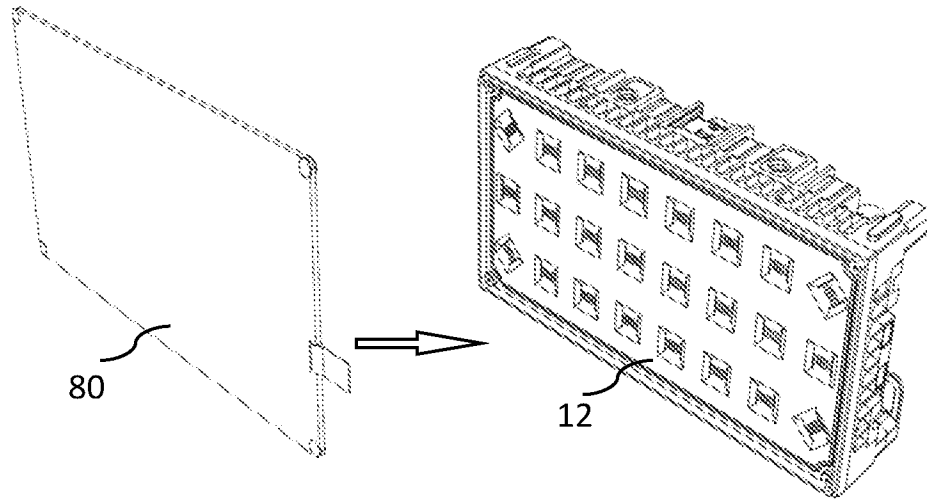

FIG. 8

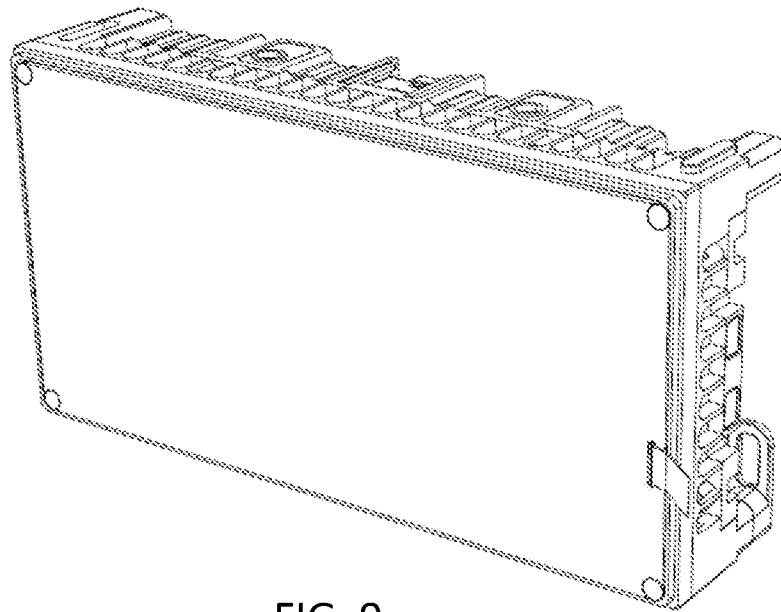

FIG. 9

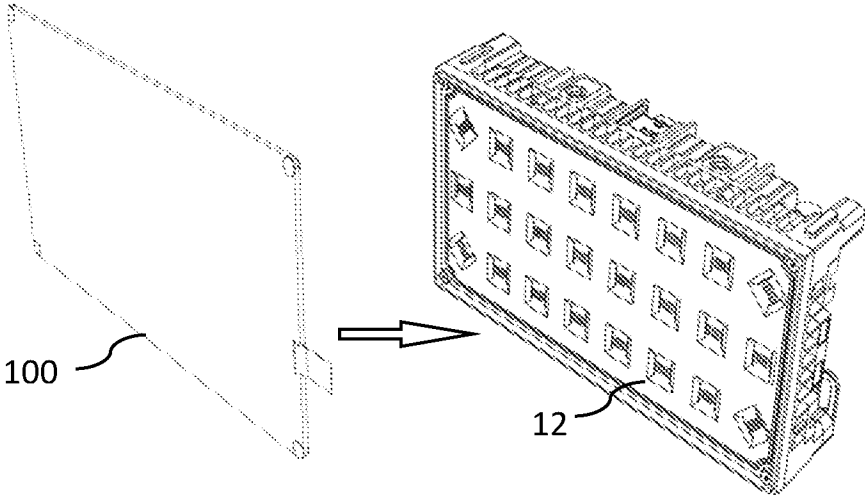

FIG. 10

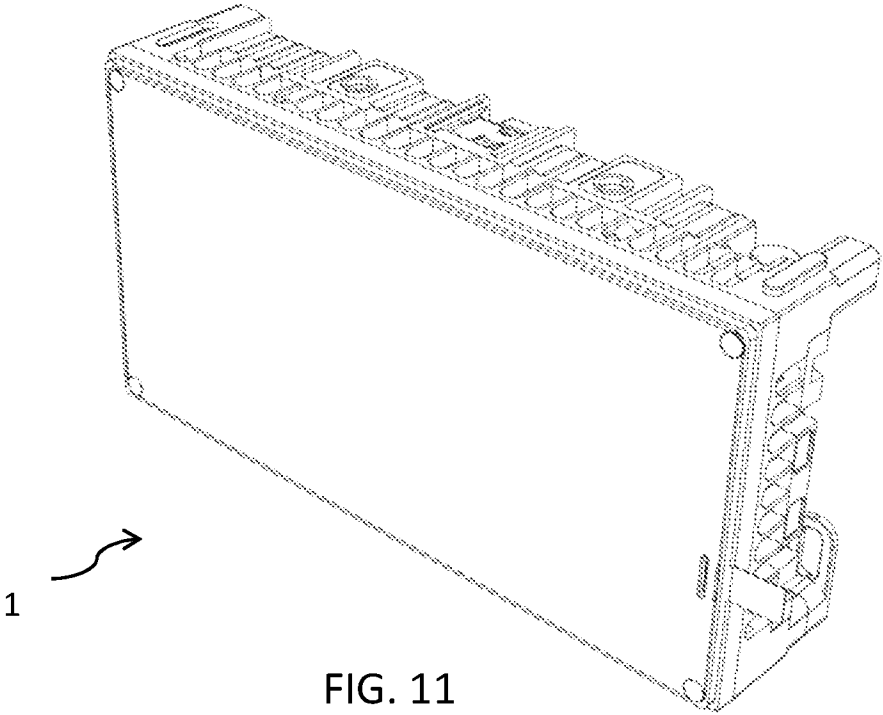

FIG. 11

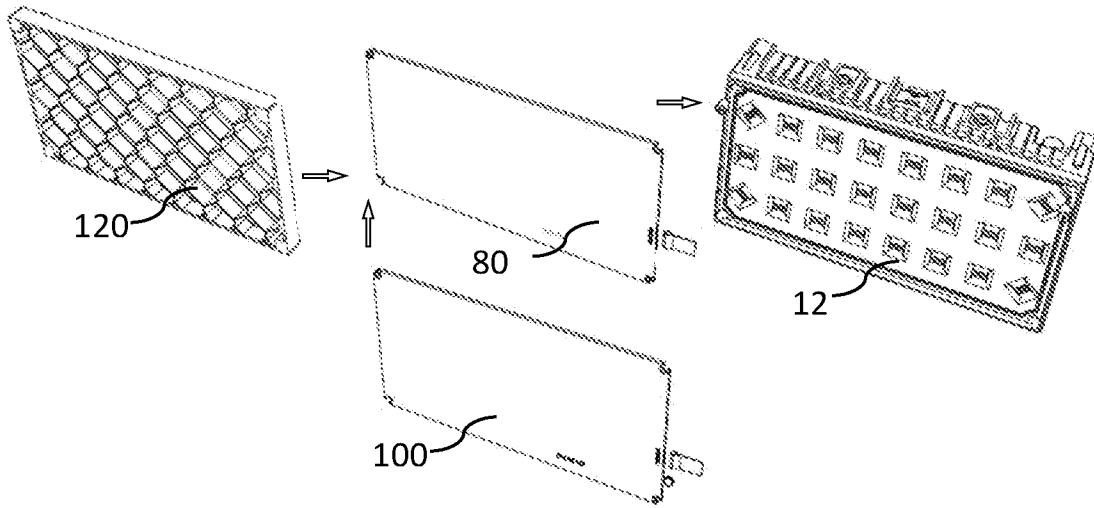

FIG. 12

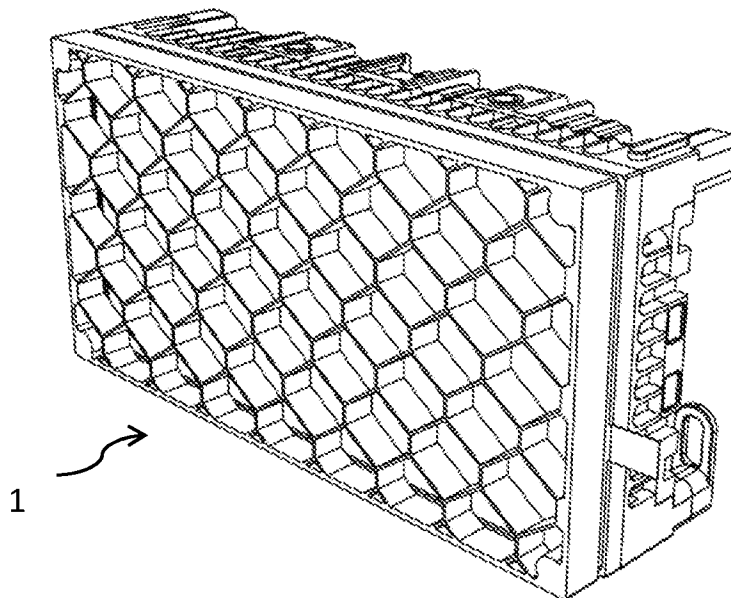

FIG. 13

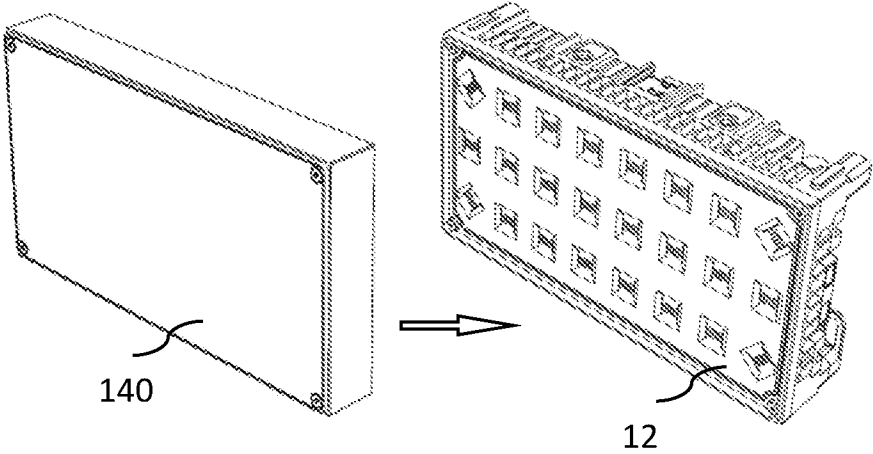

FIG. 14

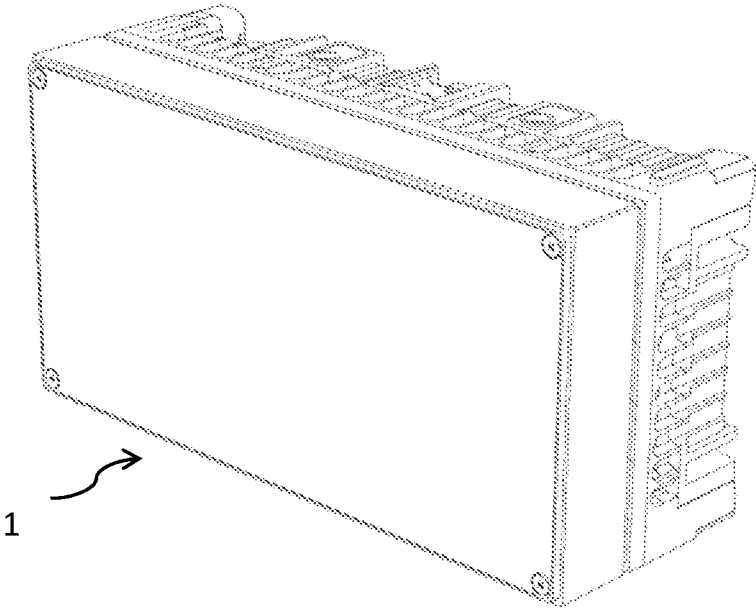

FIG. 15

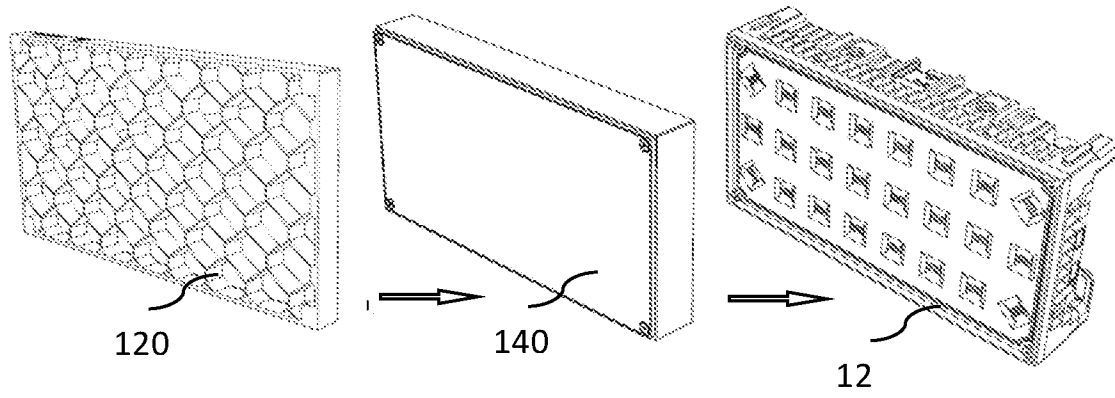

FIG. 16

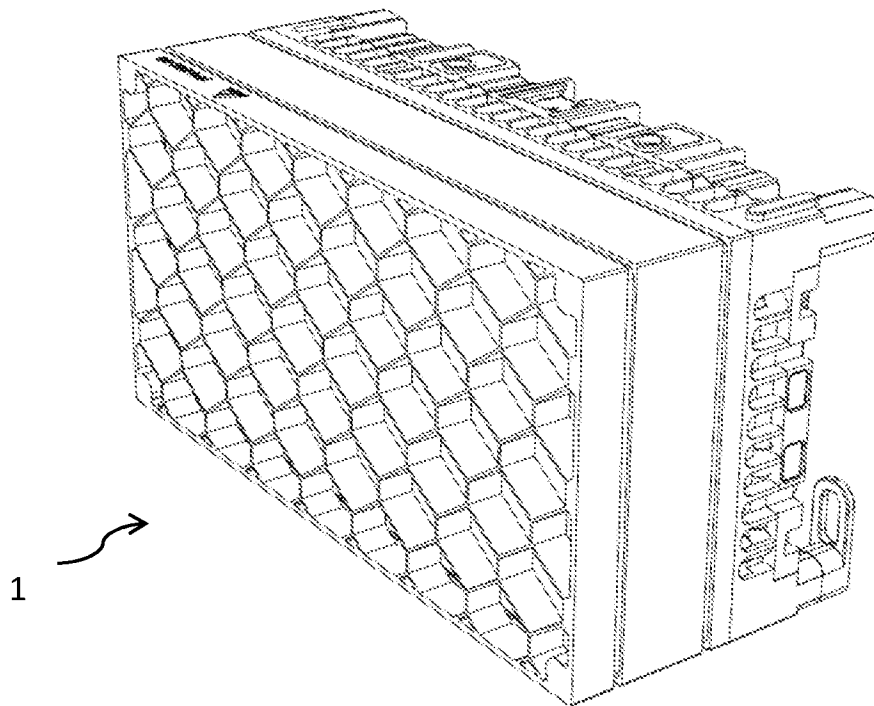

FIG. 17

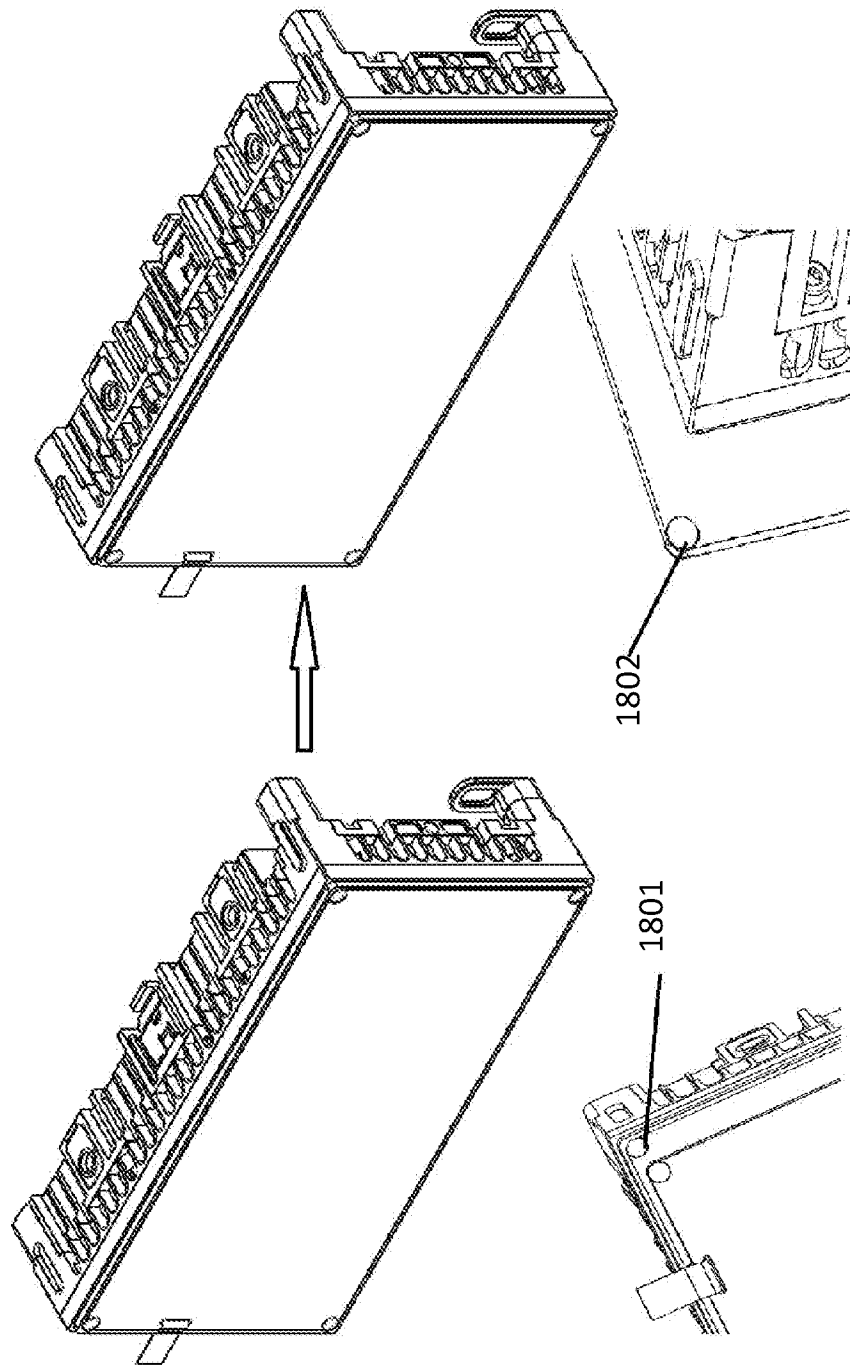

FIG. 18

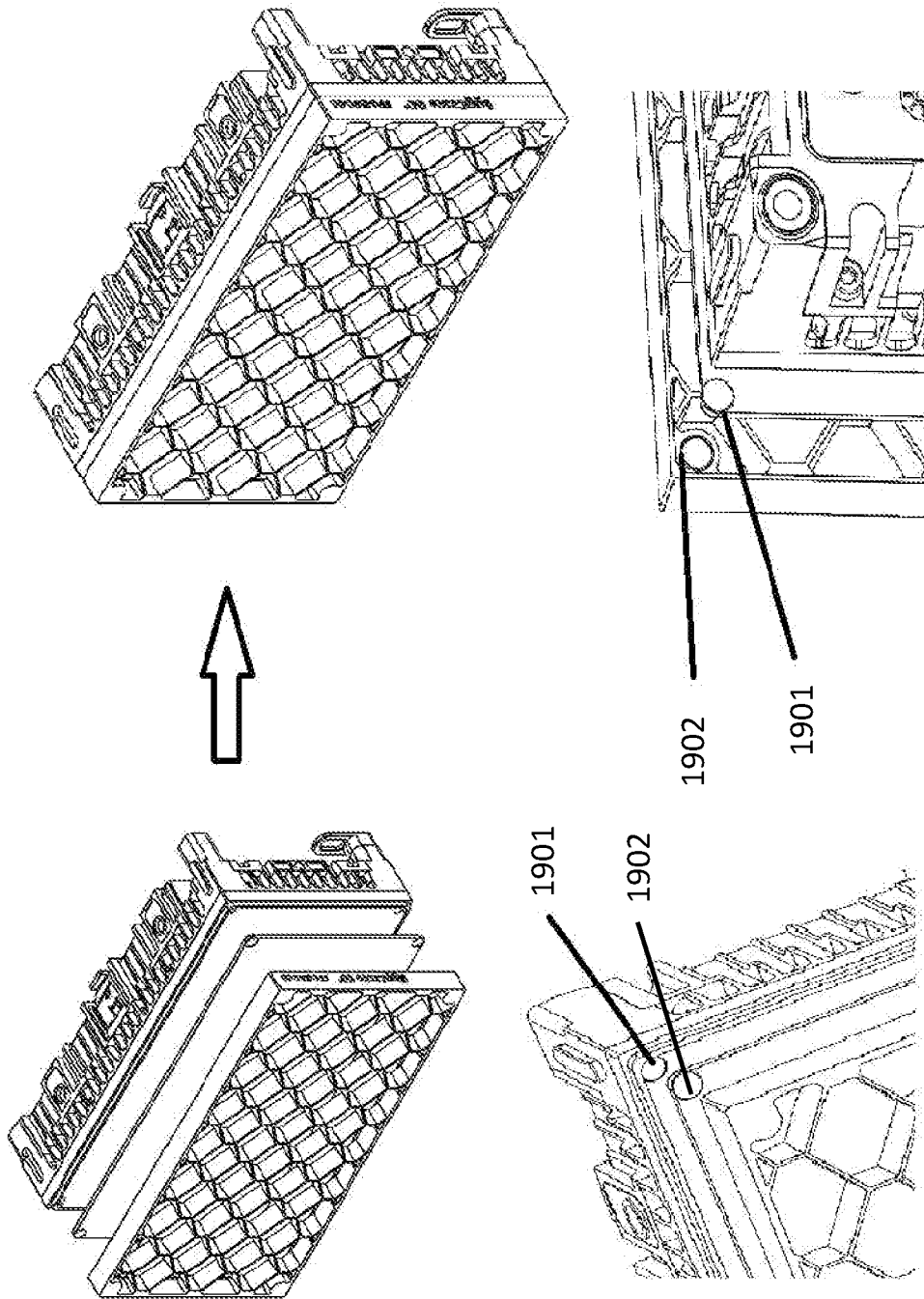

FIG. 19

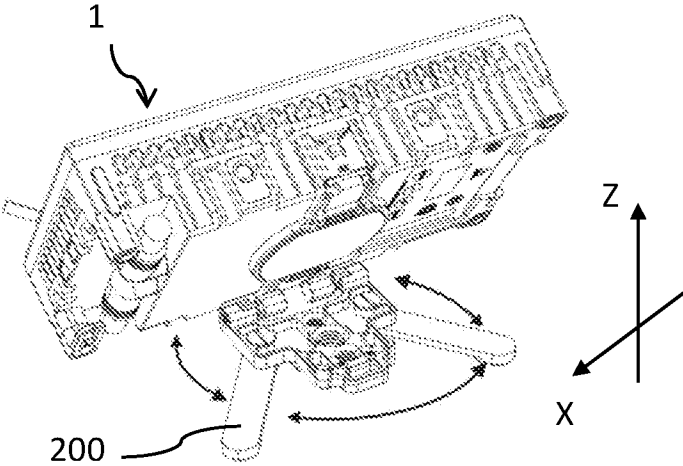

FIG. 20A

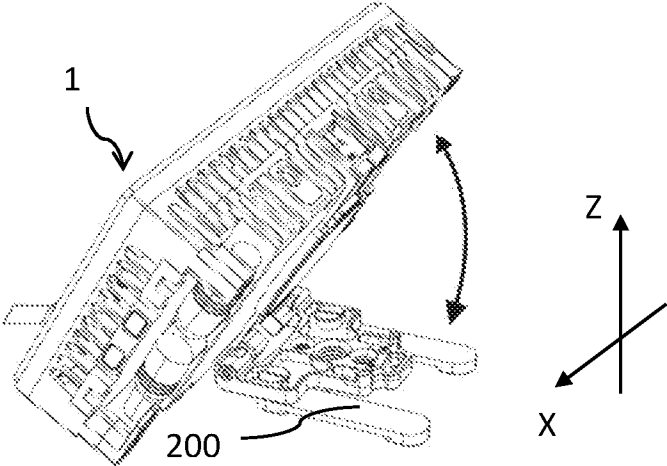

FIG. 20B

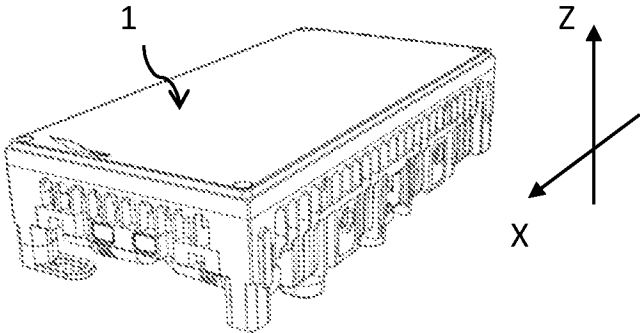

FIG. 20C

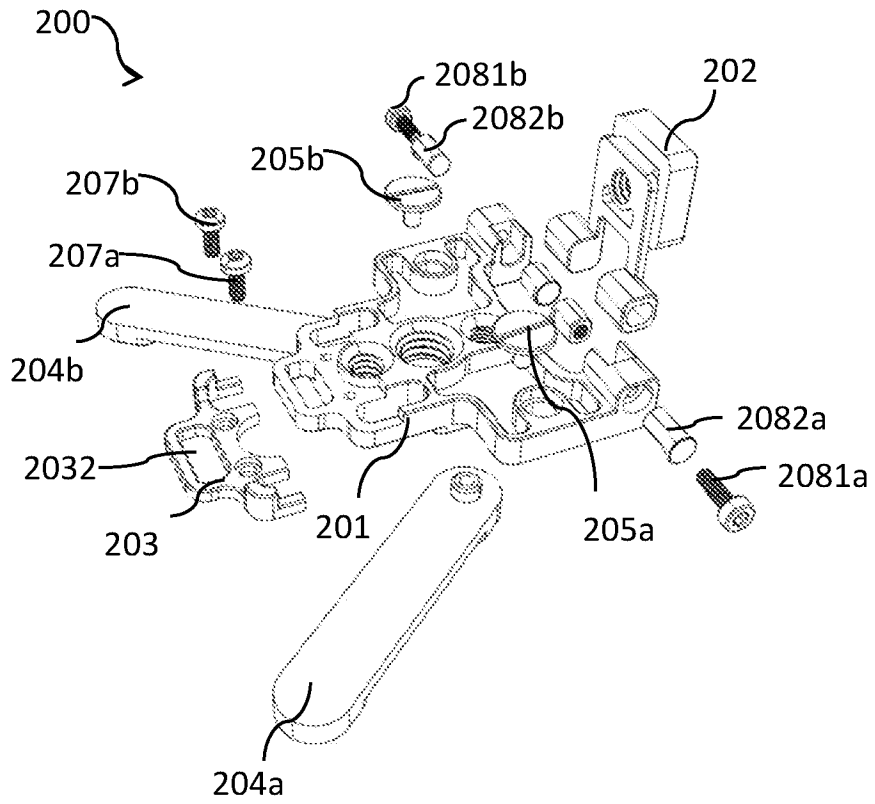

FIG. 21A

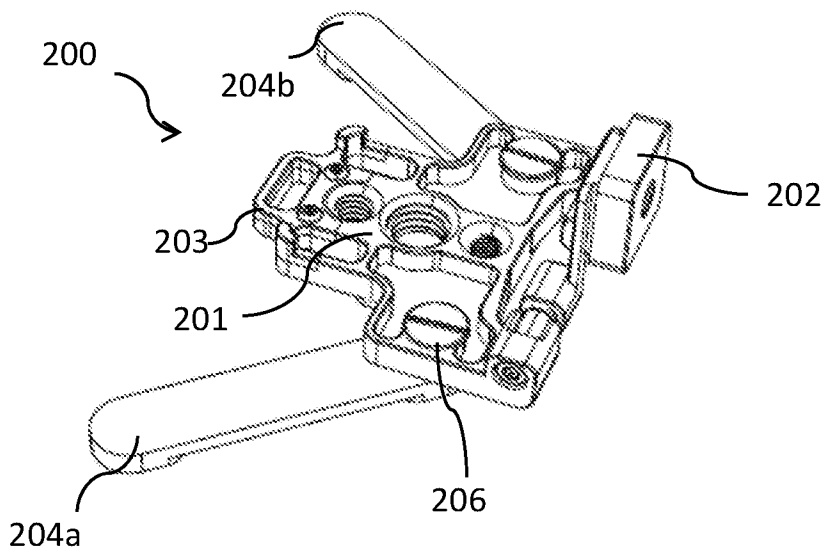

FIG. 21B

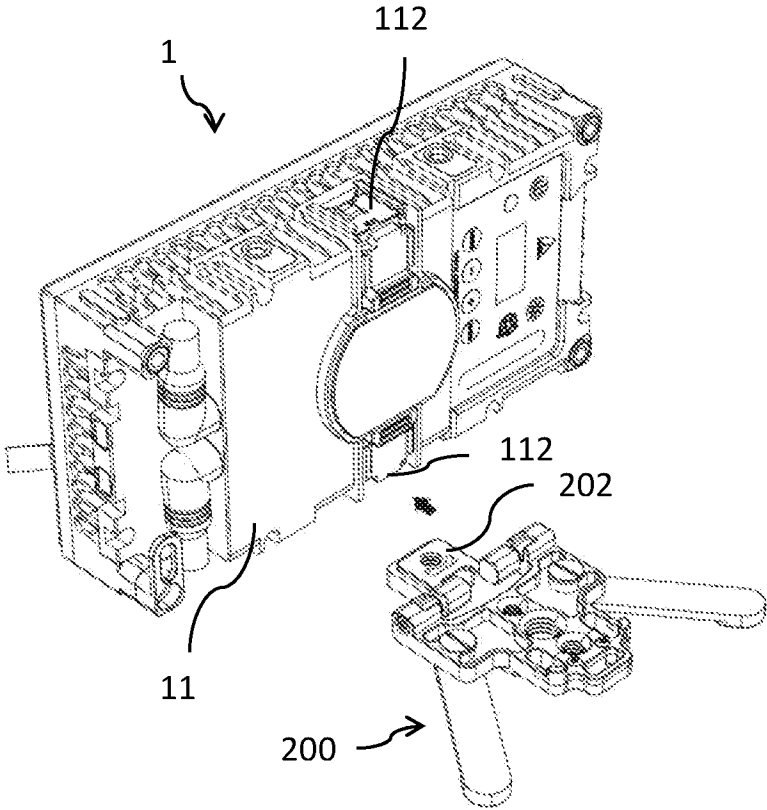

FIG. 22A

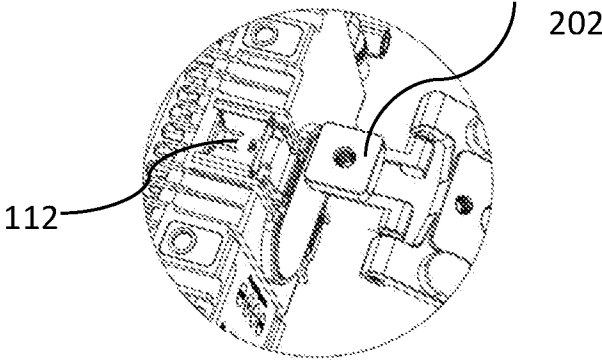

FIG. 22B

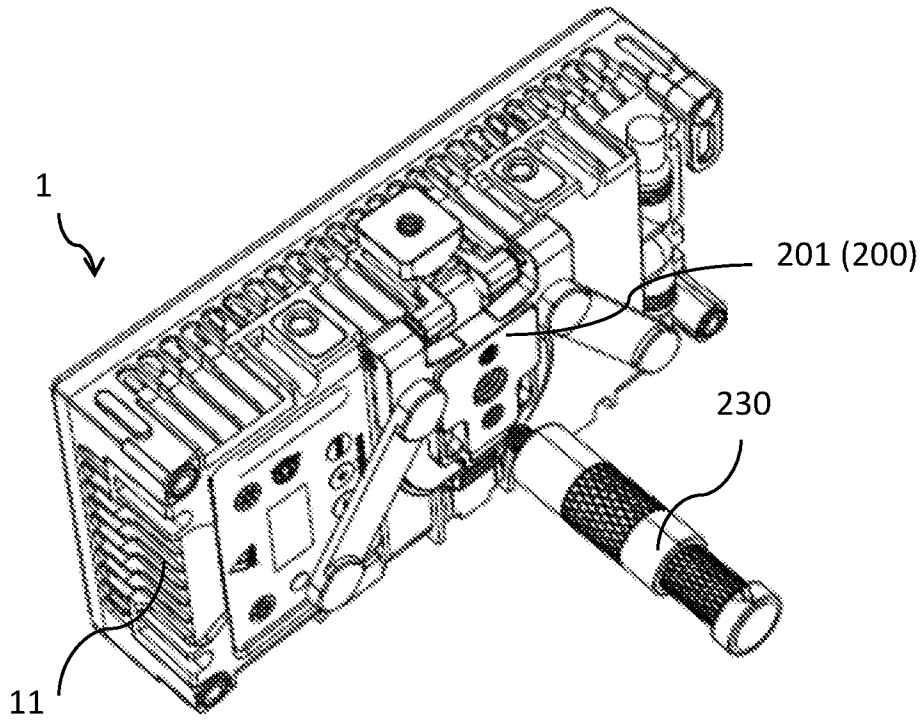

FIG. 23A

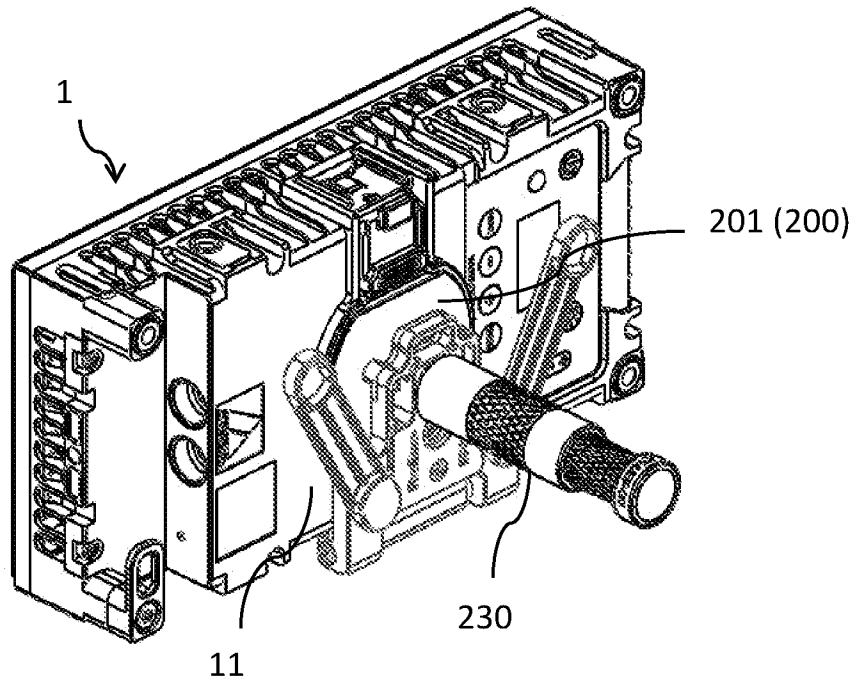

FIG. 23B

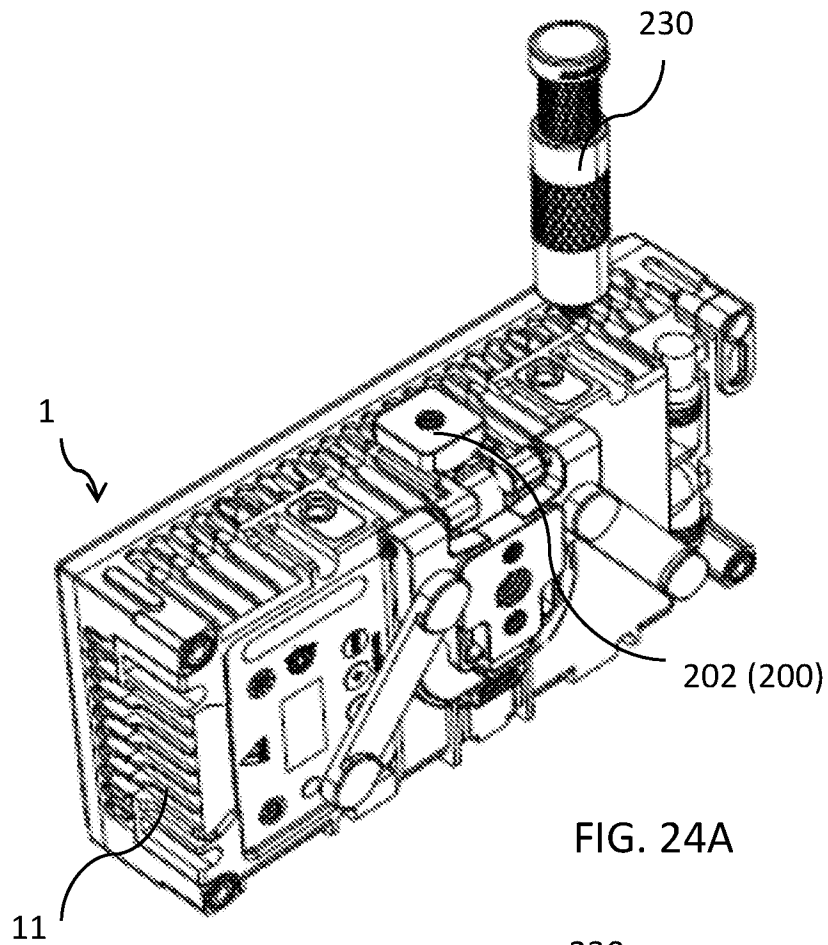

FIG. 24A

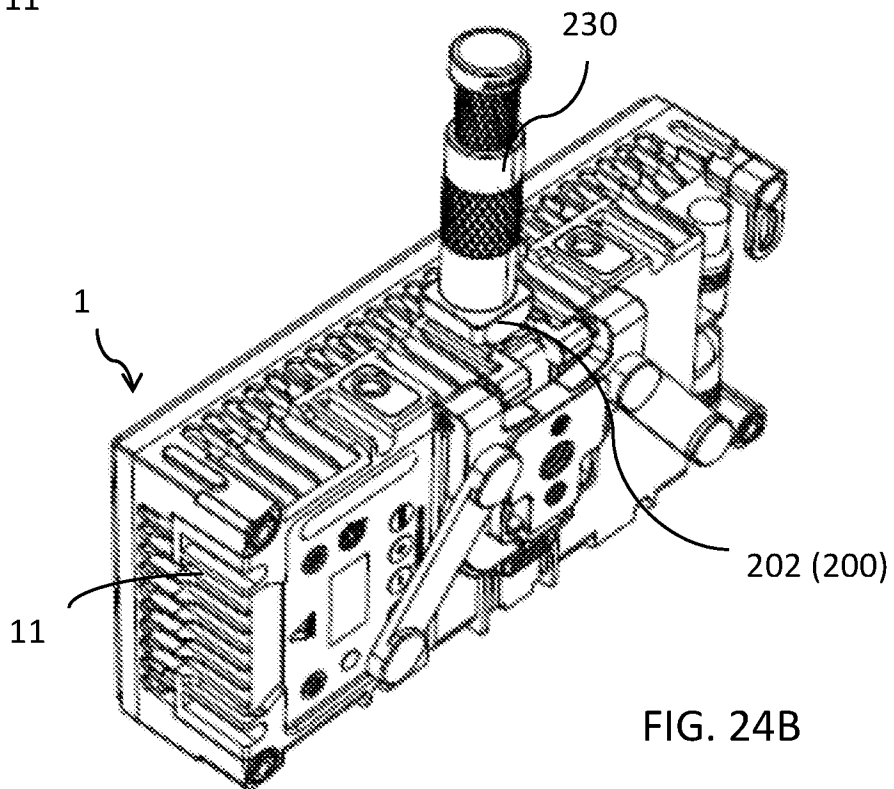

FIG. 24B

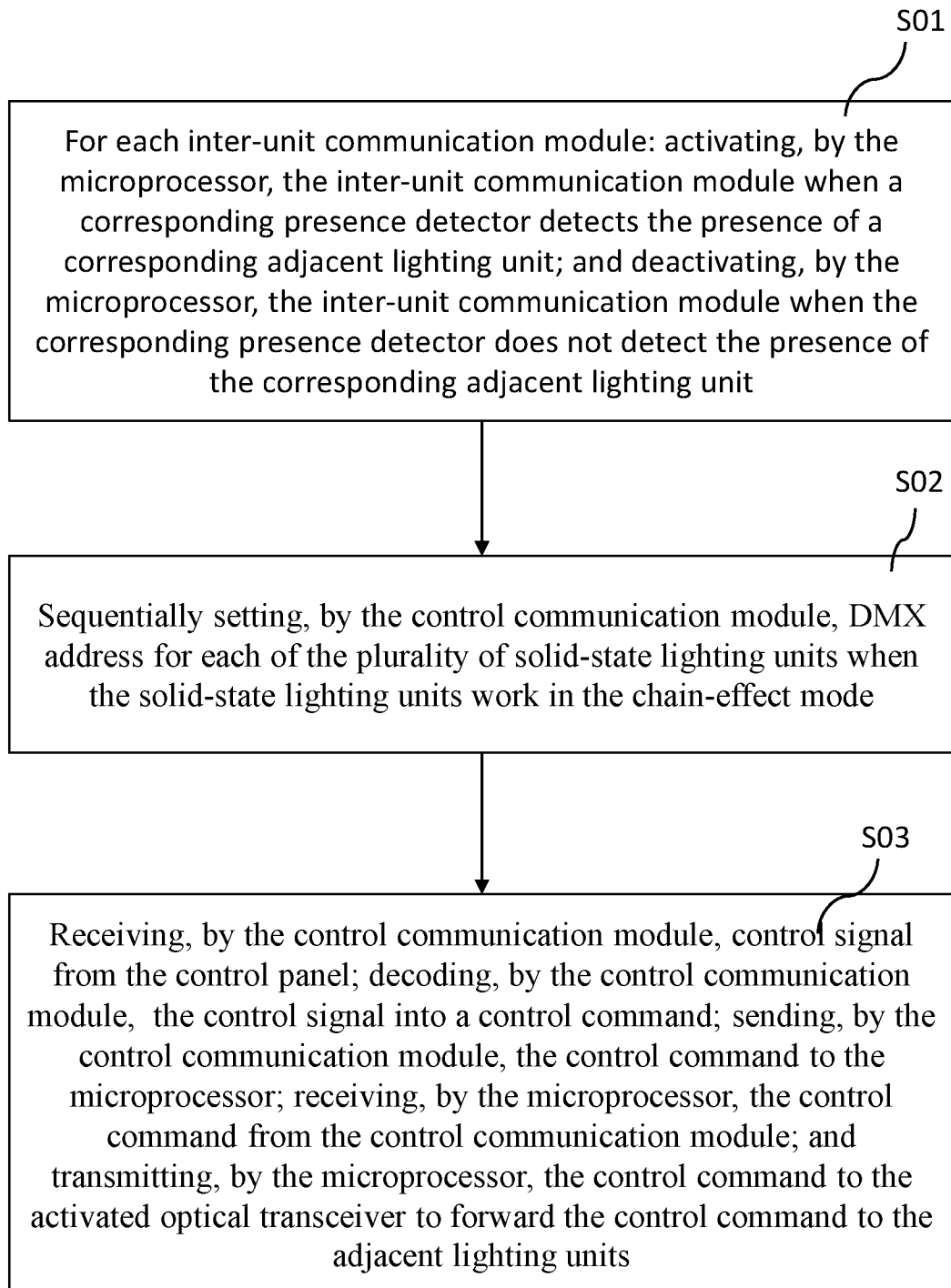

FIG. 25

SOLID-STATE LIGHT EMITTER LIGHTING APPARATUS AND METHOD OF OPERATING THE SAME

CROSS-REFERENCES TO OTHER DOCUMENTS

This application claim priority to China Patent Application no. 202221358295.6 filed 1 Jun. 2022; the disclosure of which is incorporated herein by reference in its entirety.

FIELD OF THE INVENTION

The present invention relates to the technical field of solid-state luminous body lighting, more specifically, to a matrix light-emitting diode (LED) lighting apparatus and a method of operating the same.

BACKGROUND OF THE INVENTION

LEDs are widely used in the field of lighting due to their high luminous efficiency, stable performance, low heat dissipation, and long service life. However, because the light emitted by the LED is divergent, the light irradiation distance is limited and the irradiation intensity in the effective irradiation area is not very high. Consequently, using LEDs to create spotlights still presents several technical challenges. In addition, in some large-scale activities and projects, lighting equipment needs to be installed and dismantled quickly, and different application scenarios have varying requirements for lighting area and working mode.

SUMMARY OF THE INVENTION

In order to address the above-mentioned technical challenges of LEDs in the prior art, namely their limited irradiation distance and relatively low irradiation intensity in the effective irradiation area, and to meet the demand for short-term installation and disassembly of lighting equipment in various scenarios, the present invention allows flexible combination and convenient installation/rearrangement of lighting equipment to satisfy the requirements for different lighting areas and working modes.

According to a first aspect of the present invention, provided is a solid-state lighting unit capable of communicating with one or more adjacent lighting units. The solid-state lighting unit comprises: a housing; a front cover arranged on a front side of the housing; a plurality of light sources arranged on a circuit board; a control panel arranged on a back side of the housing; a driving module electrically connected to the plurality of light sources; one or more inter-unit communication modules, each located on a corresponding side of the solid-state lighting unit and configured to communicate with an inter-unit communication module of a corresponding adjacent lighting unit connected to the lighting unit on the corresponding side; wherein each inter-unit communication module comprises: a presence detector for detecting presence of the corresponding adjacent lighting unit; a presence indicator for indicating the presence of the corresponding adjacent lighting unit; a transceiver for communicating with a corresponding optical transceiver in the corresponding adjacent lighting unit; a microprocessor electrically connected to the driving module and one or more inter-unit communication modules, and configured to control each of the inter-unit communication modules such that: the inter-unit communication module is activated when the corresponding presence detector detects

the presence of the corresponding adjacent lighting unit; and the inter-unit communication module is deactivated when the corresponding presence detector does not detect the presence of the corresponding adjacent lighting unit; and a control communication module electrically connected to the microprocessor and the control panel, and configured to: receive a control signal from the control panel; decode the control signal into a control command; and transmit the control command to the microprocessor. The microprocessor is further configured to: receive the control command from the control communication module; and transmit the control command to one or more activated optical transceivers to forward the control command to one or more adjacent lighting units respectively.

According to a second aspect of the present invention, a solid-state lighting apparatus comprising a plurality of solid-state lighting units according to the first aspect of the present invention is provided. The plurality of solid-state lighting units is operable to work in a synchronous mode or a chain-effect mode.

According to a third aspect of the present invention, a method for operating a solid-state lighting apparatus of the second aspect of the present invention to work in a synchronous mode or a chain-effect mode is provided. The method comprises three stages: detection of the presence of adjacent lighting units; setting of digital multiplexing (DMX) addresses of adjacent lighting units; and communication between adjacent lighting units.

BRIEF DESCRIPTION OF THE DRAWINGS

FIGS. 1A, 1B and 1C show a front perspective view, a rear perspective view and an exploded view of a solid-state lighting unit communicable with adjacent lighting units according to an embodiment of the present invention respectively.

FIG. 2A shows a block diagram of a solid-state lighting unit according to one embodiment of the present invention;

FIG. 2B shows a block diagram of a solid-state lighting unit according to another embodiment of the present invention;

FIG. 3A shows a solid-state lighting apparatus comprising a plurality of solid-state lighting units of FIG. 2A;

FIG. 3B shows a solid-state lighting apparatus comprising a plurality of solid-state lighting units of FIG. 2B;

FIG. 4 shows a schematic diagram of how two adjacent solid-state lighting units communicate with each other according to some embodiments of the present invention;

FIGS. 5A-5B show schematic diagrams of how two adjacent solid-state lighting units are mechanically connected according to some embodiments of the present invention;

FIGS. 6-7 illustrate the structure of a mechanical connector according to some embodiments of the present invention;

FIGS. 8-17 show how different optical components are attached to the front cover to form lighting units with different specifications and functions according to some embodiments of the present invention;

FIGS. 18-19 show schematic diagrams of how to attach or detach different optical components on the front cover through the coupling of magnets and iron chips according to some embodiments of the present invention;

FIGS. 20A-20C illustrate a solid-state lighting unit installed with a removable supporting member according to some embodiments of the present invention;

FIGS. 21A-21B show structural views of a removable support;

FIGS. 22A-22B show schematic diagrams of how to mount the removable supporting member to a solid-state lighting unit;

FIGS. 23A-23B illustrate a solid-state lighting unit installed with a pin mount on back side according to some embodiments of the present invention;

FIGS. 24A-24B illustrate a solid-state lighting unit installed with a pin socket according to other embodiments of the present invention.

FIG. 25 illustrates a method of operating a solid-state lighting unit in combination with one or more lighting units to form a solid-state lighting apparatus which can work as a virtual single lighting unit in synchronous mode or chain-effect mode.

DETAILED DESCRIPTION

The present invention is described in further detail below in conjunction with accompanying drawing and specific embodiments.

FIGS. 1A, 1B and 1C show a front perspective view, a rear perspective view and an exploded view of a solid-state lighting unit communicable with adjacent lighting units according to an embodiment of the present invention respectively.

FIG. 2A shows a block diagram of a solid-state lighting unit 1A according to one embodiment of the present invention. Referring to FIGS. 1A-1C and 2A, solid-state lighting unit 1A may include: housing 11, front cover 12, driving module 13, inter-unit communication modules 14A-14B, microprocessor 15, control communication module 16, control panel 17 and a plurality of light sources 18. The front cover 12 is arranged on front side of the housing 11. The material of the housing 11 can be any plastic suitable for injection molding. The interface between the housing 11 and the front cover 12 can be sealed by a sealing ring. Accessory shoes 112 may be arranged on upper and lower sides of the housing 11, respectively. Each accessory shoe 112 includes a slot 1121 for receiving accessory connection and a spring tensioner 1122 for locking the accessory connection. The driving module 13, the inter-unit communication modules 14A-14B, the microprocessor 15, the control communication module 16 and the plurality of light sources 18 are arranged on a metal circuit board 21. The control panel 17 is disposed on the back of the housing 11.

The plurality of light sources 18 can be arranged in a two-dimensional array. Light sources 18a-18d at the four corners of the array are oriented at an angle of 45° so that the light intensity distribution of the entire light source array is more uniform. Each light source 18 may comprise a plurality of LEDs with different spectra to form a uniform visible color spectrum to mitigate the influence of wavelength peaks. For example, each light source 18 can be formed of five LED chips of different colors. The five LED chips may include red LEDs, green LEDs, fluorescent green LEDs, blue LEDs, and fluorescent amber LEDs.

The solid-state lighting unit 1A may further include a reflective plate 19 disposed between the front cover 12 and the circuit board 21. The reflective plate 19 has a plane 191 and a plurality of windows 192 protruding from the plane 191, corresponding to the positions of the plurality of light sources 18 respectively. Each window has an inclined reflective surface 193 on its periphery, extending from the edge of the window 192 to the plane 191, for reflecting and diffusing the light emitted by the plurality of light sources 18.

The solid-state lighting unit 1A may also include a built-in heat sink 22, which is bonded with the metal circuit board

21 through heat-dissipating glue. The material of the heat sink 22 can be any metal or alloy with high thermal conductivity, such as aluminum. Each side of the housing 11 may include a plurality of ventilation holes 114 to cooperate with the heat sink pins of the heat sink 22 to perform the heat dissipation function more effectively. The solid-state lighting unit 1A may further include a magnet 113 disposed at the center of the back of the housing 11 to allow the solid-state lighting unit 1A to be easily attached to a (magnetic) metal surface.

The driving module 13 is electrically connected to the plurality of light sources 18. Inter-unit communication modules 14A-14B are located on opposite sides A and B, respectively, of solid-state lighting unit 1A and are configured to communicate with inter-unit communication modules (not shown) of corresponding adjacent lighting units connected to the lighting unit 1A on respective sides.

Inter-unit communication modules 14A-14B may include presence detectors 141A-141B, respectively, for detecting the presence of corresponding adjacent lighting units. Inter-unit communication modules 14A-14B may also include presence indicators 142A-142B, respectively, for indicating the presence of a lighting unit to corresponding adjacent lighting units.

Inter-unit communication modules 14A-14B may also include optical transceivers 143A-143B, respectively, for communicating with corresponding optical transceivers (not shown) in corresponding adjacent lighting units. The optical transceiver 143A includes a transmitter 1431A and a receiver 1432A. The optical transceiver 143B includes a transmitter 1431B and a receiver 1432B.

The microprocessor 15 is electrically connected to the driving module 13 and the inter-unit communication modules 14A-14B and is configured to control the inter-unit communication modules 14A-14B respectively so that: when the corresponding presence detector of each inter-unit communication module detects the presence of a corresponding adjacent lighting unit, the inter-unit communication module is activated; when the presence detector corresponding to each inter-unit communication module does not detect the presence of the corresponding adjacent lighting unit, the inter-unit communication module is deactivated. In this way, it is possible to prevent the inter-unit communication module from sending out signals when the lighting unit 1A is used alone or not connected to adjacent lighting units on the corresponding side of the inter-unit communication module, causing interference to other nearby lighting units.

The control communication module 16 is electrically connected to the microprocessor 15 and configured to: receive the control signal; decode the control signal into a control command; and transmit the control command to the microprocessor 15. The control communication module 16 is configured to be electrically connected to the control panel 17 and to receive the control signals from the control panel. The control communication module 16 may also include a wireless communication module for receiving external wireless control signals; and/or a wired communication module for receiving external wired control signals. The wireless control signal can come from an external controller, such as a dedicated remote control or a smart device installed with a dedicated application. The wireless communication module can be configured to support various communication technologies, such as Bluetooth, WiFi and zigbee . . . etc. The wired communication module can be configured to receive wired control signals superimposed with DMX data signals through DMX data lines or power lines.

The microprocessor **15** is further configured to: receive a control command from the control communication module **16**; and transmit the control command to the activated optical transceiver to forward the control command to the corresponding adjacent lighting unit.

The lighting unit **1A** may be powered by a built-in battery or an external power supply. The lighting unit **1A** may also include an electrical socket for conveniently connecting to a power source to provide continuous power supply or to charge the built-in battery. The electrical socket can also be used with a dedicated charging stand or case to prevent short circuits and reverse polarity power connections when the lighting unit **1A** is being charged. The lighting unit **1A** can also be connected to other lighting units in a daisy chain format through a power line superimposed with DMX data signals to form a single lighting unit for operation and control.

FIG. **2B** shows a block diagram of a solid-state lighting unit **1B** according to another embodiment of the present invention. Referring to FIGS. **1A-1C** and **2B**, solid-state lighting unit **1B** is similar to solid-state lighting unit **1A**. The difference between the solid-state lighting unit **1B** and the solid-state lighting unit **1A** is that the solid-state lighting unit **1B** includes four inter-unit communication modules **14A-14D**, respectively located on four sides A-D of the solid-state lighting unit **1B** and configured to be connected to inter-unit communication modules of adjacent lighting units on corresponding sides of the lighting unit **1B** to communicate with the adjacent lighting units.

Inter-unit communication modules **14A-14D** may include presence detectors **141A-141D**, respectively, for detecting the presence of corresponding adjacent lighting units. Inter-unit communication modules **14A-14D** may also include presence indicators **142A-142D**, respectively, for indicating the presence of lighting unit **1B** to corresponding adjacent lighting units.

Inter-unit communication modules **14A-14D** may also include optical transceivers **143A-143D**, respectively, for communicating with optical transceivers in corresponding adjacent lighting units. The optical transceiver **143A** includes a transmitter **1431A** and a receiver **1432A**. The optical transceiver **143B** includes a transmitter **1431B** and a receiver **1432B**. The optical transceiver **143C** includes a transmitter **1431C** and a receiver **1432C**. The optical transceiver **143D** includes a transmitter **1431D** and a receiver **1432D**.

In some embodiments, presence indicators **142A-142D** may be magnets and presence detectors **141A-141D** may be Hall effect sensors. Optical transceivers **143A-143D** may be any transceiver suitable for exchanging optical signals over short distances in free space. In some embodiments, optical transceivers **143A-143D** may be infrared transceivers. In some embodiments, the optical transceivers **143A-143D** may communicate with corresponding optical transceivers in adjacent lighting units based on a universal asynchronous transceiver (UART) communication protocol.

FIG. **3A** shows a schematic diagram of a solid-state lighting apparatus **3A** composed of a plurality of solid-state lighting units $1A_i$, $i=1, \dots, M$, where M is a positive integer. The plurality of solid-state lighting units $1A_i$ are arranged side by side to form a one-dimensional array. Each solid-state lighting unit **1A** can communicate with two adjacent solid-state lighting units respectively through two inter-unit communication modules. For example, unit $1A_i$ can communicate with unit $1A_{i-1}$ and unit $1A_{i+1}$ respectively through the inter-unit communication module. In this way, the user can control the connected solid-state lighting units through

the control panel of any one of the connected solid-state lighting units. Alternatively, the user can control the connected solid-state lighting units by communicating with the control communication module of any one of the connected solid-state lighting units through a remote control or smart device.

The plurality of solid-state lighting units $1A_i$ in the solid-state lighting apparatus **3A** can be operated and controlled as a single lighting unit and configured to work in a synchronous mode or a chain-effect mode. In the synchronous mode, the plurality of solid-state lighting units $1A_i$ respond synchronously to commands input by the user. In the chain-effect mode, the plurality of solid-state lighting units **1A**, are configured to sequentially respond to user input commands to achieve some dynamic lighting or animation effects. When the plurality of solid-state lighting units **1A**, work in the chain-effect mode, the control communication module in each solid-state lighting unit is configured to sequentially set the DMX address for the lighting units.

FIG. **3B** shows a schematic diagram of a solid-state lighting apparatus **3B** composed of a plurality of solid-state lighting units $1B_{i,j}$, $i=1, \dots, M$, and $j=1, \dots, N$, wherein N and M are positive integers. The plurality of solid-state lighting units $1B_{i,j}$ are arranged side by side to form a two-dimensional array. Each of solid-state lighting unit $1B_{i,j}$ can communicate with four adjacent solid-state lighting units respectively through four inter-unit communication modules. For example, unit $1B_{i,j}$ can communicate with unit $1B_{i-1,j}$, unit $1B_{i+1,j}$, unit $1B_{i,j-1}$ and unit $1B_{i,j+1}$ respectively through the inter-unit communication module. In this way, the user can control the connected solid-state lighting units through the control panel of any one of the connected solid-state lighting units. Alternatively, a user may operate the connected solid-state lighting units by communicating with the control communication module **16** of any one of the connected solid-state lighting units through a remote control or smart device.

The plurality of solid-state lighting units $1B_{i,j}$ in the solid-state lighting apparatus **3B** can be operated and controlled as a single lighting unit and configured to work in a synchronous mode or a chain effect mode. In the synchronous mode, the plurality of solid-state lighting units $1B_{i,j}$ respond to commands input by the user synchronously. In the chain-effect mode, the plurality of solid-state lighting units $1B_{i,j}$ are configured to sequentially respond to user input commands to achieve some dynamic lighting or animation effects. When the plurality of solid-state lighting units $1B_{i,j}$ work in the chain-effect mode, the control communication module in each solid-state lighting unit is configured to sequentially set the DMX address for the lighting units.

FIG. **4** shows a schematic diagram of how two solid-state lighting units **1** and **2** communicate with each other. As shown in FIG. **4**, when the lighting unit **2** approaches the lighting unit **1** from side A of the lighting unit **1**, the presence detector **141A** on side A of the lighting unit **1** will sense a signal emitted by presence indicator **242B** on side B of the lighting unit **2**, thereby detect the presence of the lighting unit **2**. After presence detector **141A** detects the presence of lighting unit **2**, optical transceiver **143A** on side A of lighting unit **1** is activated to communicate with optical transceiver **243B** on side B of lighting unit **2**. More specifically, the transmitter **1431A** is activated to transmit a signal to the receiver **2432B**; and the receiver **1432A** is activated to receive the signal transmitted by the transmitter **2431B**.

On the other hand, the presence detector **241B** on the B side of the lighting unit **2** will sense a signal from the

presence indicator **142A** on the A side of the lighting unit **1**, thereby detect the presence of the lighting unit **1**. After presence detector **241B** detects the presence of lighting unit **1**, optical transceiver **243B** on side B of lighting unit **2** is activated to communicate with optical transceiver **143A** on side A of lighting unit **1**. More specifically, the transmitter **2431B** is activated to transmit a signal to the receiver **1432A**; and the receiver **2432B** is activated to receive the signal transmitted by the transmitter **1431A**.

In the case where presence indicators **142A-142D** are magnets and presence detectors **141A-141D** are Hall-effect sensors, when lighting unit **2** approaches lighting unit **1** from side A of lighting unit **1**, the Hall-effect sensor on the side A of the lighting unit **1** will sense magnetic field changes caused by the magnet on side B of the lighting unit **2**, thereby detect the presence of the lighting unit **2**. On the other hand, when lighting unit **1** approaches the lighting unit **2** from side B of the lighting unit **2**, the Hall effect sensor on the B side of the lighting unit **2** will sense magnetic field changes caused by the magnet on the A side of the lighting unit **1**, thereby detect the presence of lighting units **1**.

FIGS. **5A** and **5B** show schematic diagrams of how two adjacent solid-state lighting units **1** and **2** are mechanically connected according to some embodiments of the present invention. Referring to FIG. **5A**, the housing **11** of the solid-state lighting unit **1** may include grooves **115** and protrusions **116**, which cooperate with corresponding protrusions and grooves (not shown) on the housing of the solid-state lighting unit **2**, respectively, to prevent the solid-state lighting units **1** and **2** from mutually shifting after assembling. Referring to FIG. **5B**, any two adjacent solid-state lighting units **1** and **2** can be mechanically connected through a mechanical connector **50**.

Referring to FIGS. **6-7**, the mechanical connector **50** may include jackscrews **51** and **52**, a frame **53** and an interconnect protrusion **54**. The jackscrews **51** and **52** are respectively located at two ends of the frame **53** along an axis Z, and the interconnect protrusion **54** protrudes laterally from a central part of the frame **53** along an axis Y orthogonal to the axis Z. The interconnect protrusion **54** has a block portion **541** and a block portion **542** opposite to the block portion **541** along the axis Z. The interconnect protrusion **54** also has a groove **543** defined on a first side and a groove **544** defined on a second side opposite to the first side, both extending through the interconnect protrusion **54** along the axis Y and between block portions **541** and **542**. Accordingly, when the solid-state lighting units **1** and **2** are mechanically connected by the mechanical connector **50**, the block portions **541**, **542** of the interconnect protrusion **54** are inserted into the slots **1121** (see FIG. **1B**) of the accessory shoes **112** of the adjacent lighting units **1** and **2**, respectively, and locked by the spring tensioners **1122** (see FIG. **1B**) of the accessory shoes **112** of the lighting units **1** and **2**, respectively. The jackscrews **51** and **52** can then be used to apply loading to the back of the lighting units **1** and **2** respectively (see FIG. so that the lighting units **1** and **2** are aligned with each other along the axis Y. The frame **53** may also include threaded holes **531**, **532**, **533** and **534** for fixing other accessories.

FIGS. **8-17** show lighting units attached with different optical components to provide various specifications and functions according to some embodiments of the present invention.

Referring to FIGS. **8** and **9**, the solid-state lighting unit **1** may include a gel holder **80**. The gel holder **80** is removably attached to the front cover **12** for accommodating one or more color filters.

Referring to FIGS. **10** and **11**, the solid-state lighting unit **1** may include a diffuser **100**. The diffusion **100** is removably attached to the front cover **12** and configured to diffuse light output from the plurality of solid-state light sources.

Referring to FIGS. **12-13**, the solid-state lighting unit **1** may include a gel holder **80**, a diffuser **100** and an egg-crate-grille adjuster **120**. The gel holder **80** is removably attached to the front cover **12** for accommodating one or more color filters. The diffuser **100** is removably attached to the gel holder **80** and configured to diffuse light output from the plurality of solid-state light sources. The egg-crate-grille adjuster **120** is removably attached to the diffuser **100** for blocking off-axis light scattered by the diffuser **100**. The egg-crate-grille adjuster **120** can have various grid sizes to suit different requirements.

Referring to FIGS. **14-15**, the solid-state lighting unit **1** may include an intensifier **140**. The intensifier **140** is removably attached to the front cover **12** for intensifying the light output from the plurality of solid-state light sources. The intensifier **140** can have different thicknesses to suit different requirements.

Referring to FIGS. **16-17**, the solid-state lighting unit **1** may include an intensifier **140** and an egg-crate-grille adjuster **120**. The intensifier **140** is removably attached to the front cover **12** for intensifying the light output from the plurality of solid-state light sources. The egg-crate-grille adjuster **120** is removably attached to intensifier **140** for blocking off-axis light. The egg-crate-grille adjuster **120** can have various grid sizes to suit different requirements.

Referring to FIGS. **18-19**, the front cover **12** can attach or detach different optical parts or light modifying accessories (such as gel holders, diffusers, egg-crate-grille adjusters, intensifiers) through the coupling of magnets and iron chips to form lighting units with different specifications and functions. As shown in FIG. **18**, the front cover **12** may include magnets **1801** at four corners, and the gel holder may include iron chips **1802** at four corners. The shapes of the magnet match the shape of the iron chips, and the positions of the magnets match the positions of the iron chips. In this way, the gel holder can be attached to the front cover **12** or detached from the front cover **12** conveniently. As shown in FIG. **19**, the diffuser may include magnets **1901** at four corners, and the egg-crate grille adjuster may include iron chips **1902** at four corners corresponding to the magnets **1901**. In this way, the egg-crate-grille adjuster can be easily attached to or detached from the diffuser.

Referring to FIGS. **20A-20C**, the solid-state lighting unit **1** may further include a removable supporting member **200** fixed on the housing **11**. The supporting member **200** can allow the solid-state lighting unit **1** to rotate along the horizontal axis X or the vertical axis Z to adjust the direction of illumination.

Referring to FIGS. **21A** and **21B**, the supporting member **200** may include: a main body **201** for being attached with one or more mounting accessories, a connector **202**, a fixing element **203**. The one or more mounting accessories may include first and second brackets **204a**, **204b**. The connector **202** is hinged to the main body **201** by screws **2081a** and **2081b**, bearings **2082a** and **2082b**, and is used to connect the supporting member **200** to the housing and allow the solid-state lighting unit to rotate along the horizontal axis X through the supporting member **200** to adjust the direction of illumination. The fixing element **203** is fixed on the main body **201** by screws **207a** and **207b**. The fixing element **203** has an opening **2032** to allow the solid-state lighting unit to be fixed using wire or cable ties. The first bracket **204a** and the second bracket **204b** are rotatably fixed on the main body

201 by screws 205a and 205b respectively, for allowing the solid-state lighting unit 1 to stand on a platform and rotate along the vertical axis Z through the supporting member 200.

Referring to FIGS. 22A and 22B, the connector 202 is shaped to match the accessory shoe 112 on the side of the housing 11 of the solid-state lighting unit 1. When the supporting member 200 is mounted on the housing 11 of the solid-state lighting unit 1, the connector 202 can be snugly inserted into the accessory shoe 112 on the housing 11.

In some embodiments, as shown in FIGS. 23A-24B, the one or more mounting accessories may include a pin socket 230 fixed on the supporting member 200 to allow the solid-state lighting unit 1 to be used with other standard lighting devices. As shown in FIGS. 23A and 23B, a pin socket 230 may be mounted on the main body 201 of the supporting member 200. In other words, the pin socket 230 may be connected to the back of the housing 11 through the supporting member 200. As shown in FIGS. 24A and 24B, the pin socket 230 may be mounted on the connector 202 of the supporting member 200. In other words, the pin socket 230 may be connected to the side of the housing through the supporting member 200.

FIG. 25 illustrates a method of operating a solid-state lighting unit in combination with one or more lighting units to form solid-state lighting apparatus which can work as a virtual single lighting unit operating in synchronous mode or chain-effect mode. The method includes three stages, namely: S01: detection of the presence of adjacent lighting units; S02: setting of DMX addresses of adjacent lighting units; and S03: communication between adjacent lighting units.

Stage S01 (detection of the presence of adjacent lighting units) comprises: for each inter-unit communication module: activating, by the microprocessor, the inter-unit communication module when a corresponding presence detector detects the presence of a corresponding adjacent lighting unit; and deactivating, by the microprocessor, the inter-unit communication module when the corresponding presence detector does not detect the presence of the corresponding adjacent lighting unit.

Stage S02 (setting of DMX addresses of adjacent lighting units) comprises: sequentially setting, by the control communication module, DMX address for each of the plurality of solid-state lighting units when the solid-state lighting units work in the chain-effect mode.

Stage S03 (communication between adjacent lighting units) includes: receiving, by the control communication module, control signal from the control panel; decoding, by the control communication module, the control signal into a control command; sending, by the control communication module, the control command to the microprocessor; receiving, by the microprocessor, the control command from the control communication module; and sending, by the microprocessor, the control command to the activated optical transceiver to forward the control command to the adjacent lighting units.

The embodiment was chosen and described in order to best explain the principles of the invention and its practical application, thereby enabling others skilled in the art to understand various embodiments of the invention and various embodiments as are suited to the particular use contemplated. kind of modification. Although the devices disclosed herein have been described with reference to specific structures, shapes, materials, compositions of matter and relationships, etc., such descriptions and illustrations are not limiting. Modifications may be made to adapt a particular

situation to the aim, spirit and scope of the disclosure. All such modifications are intended to come within the scope of the claims appended hereto.

The invention claimed is:

1. A solid-state lighting unit capable of communicating with one or more adjacent lighting units, comprising:

- a housing;
- a front cover arranged on a front side of the housing;
- a plurality of light sources arranged on a circuit board;
- a control panel arranged on a back side of the housing;
- a driving module electrically connected to the plurality of light sources;

one or more inter-unit communication modules, each located on a corresponding side of the solid-state lighting unit and configured to communicate with an inter-unit communication module of a corresponding adjacent lighting unit connected to the solid-state lighting unit on the corresponding side; wherein each inter-unit communication module comprises: a presence detector for detecting presence of the corresponding adjacent lighting unit; a presence indicator for indicating the presence of the corresponding adjacent lighting unit; a transceiver for communicating with a corresponding optical transceiver in the corresponding adjacent lighting unit;

- a microprocessor electrically connected to the driving module and one or more inter-unit communication modules and configured to control each of the inter-unit communication modules such that: the inter-unit communication module is activated when the corresponding presence detector detects the presence of the corresponding adjacent lighting unit; and the inter-unit communication module is deactivated when the corresponding presence detector does not detect the presence of the corresponding adjacent lighting unit; and

a control communication module electrically connected to the microprocessor and the control panel and configured to: receive a control signal from the control panel; decode the control signal into a control command; and transmit the control command to the microprocessor; and wherein, the microprocessor is further configured to: receive the control command from the control communication module; and transmit the control command to one or more activated optical transceivers to forward the control command to one or more adjacent lighting units.

2. The solid-state lighting unit according to claim 1, wherein each of the one or more optical transceivers is an infrared transceiver.

3. The solid-state lighting unit according to claim 1, wherein each of the one or more optical transceivers is a universal asynchronous transceiver (UART).

4. The solid-state lighting unit according to claim 1, wherein each of the one or more presence detectors is a Hall effect sensor.

5. The solid-state lighting unit according to claim 1, wherein each of the one or more presence indicators is a magnet.

6. The solid-state lighting unit according to claim 1, wherein the control communication module further comprises: a wireless communication module for receiving wireless control signals; and/or a wireless communication module for receiving wired control signals Wired communication module.

7. The solid-state lighting unit according to claim 1, wherein each of the light sources is composed of at least five

11

light-emitting diodes (LEDs) including at least one red LED, at least one green LED, at least one fluorescent green LED, at least one blue LED, and at least one fluorescent amber LED.

8. The solid-state lighting unit according to claim 1, further comprising a magnet disposed at center on a back side of the housing to allow the solid-state lighting unit to attach to a magnetic metal surface.

9. The solid-state lighting unit according to claim 1, further comprising one or more light modifying accessories.

10. The solid-state lighting unit according to claim 9, wherein the one or more light modifying accessories comprise a gel holder removably attached to the front cover for accommodating one or more color filters.

11. The solid-state lighting unit according to claim 10, wherein the one or more light modifying accessories further comprise a diffuser removably attached to the gel holder and configured to diffuse light emitted from the plurality of light sources.

12. The solid-state lighting unit according to claim 11, wherein the one or more light modifying accessories further comprise an egg-crate-grille adjuster removably attached to the diffuser for blocking off-axis light scattered by the diffuser.

13. The solid-state lighting unit according to claim 10, wherein the one or more light modifying accessories comprise an intensifier removably attached to the gel holder for intensifying light emitted from the plurality of light sources.

14. The solid-state lighting unit according to claim 13, wherein the one or more light modifying accessories further comprise an egg-crate-grill adjuster removably attached to the intensifier and configured to block off-axis light intensified by the intensifier.

15. The solid-state lighting unit according to claim 1, further comprising a removable supporting member fixed on the housing, the removable supporting member comprising:
a main body for being attached with one or more mounting accessories;

a connector hinged to the main body and configured to connect the body to the housing;

wherein the one or more mounting accessories include:
a first bracket and a second bracket fixed on the main body by screws respectively, and used for allowing the solid-state lighting unit to stand on a platform; and/or

a pin socket mounted to the main body or the connector.

16. A solid-state lighting apparatus comprising a plurality of solid-state lighting units according to claim 1 arranged in a matrix, wherein the plurality of solid-state lighting units is operable to work in a synchronous mode or a chain-effect mode.

17. The solid-state lighting apparatus according to claim 16, wherein when the plurality of solid-state lighting units works in chain-effect mode, the control communication module in each of the lighting units is configured to sequentially set a DMX address for the lighting unit.

18. The solid-state lighting apparatus according to claim 16, further comprising one or more mechanical connectors, each mechanical connector configured to mechanically connect a pair of first adjacent lighting units and a second adjacent lighting unit; wherein the mechanical connector comprises:

- a frame;
- a first jackscrew and a second jackscrew, respectively located at two ends along a first axis of the frame;

12

an interconnect protrusion projecting laterally from a central part of the frame along a second axis orthogonal to the first axis;

wherein the interconnect protrusion has:

a first block portion and a second block portion opposite to the first block portion along the first axis;

a first groove defined on a first side and a second groove defined on a second side opposite to the first side, both extending through the interconnect protrusion along the second axis and between the first block portion and the second block portion.

19. The solid-state lighting apparatus according to claim 18, wherein

each of the first adjacent lighting unit and the second adjacent lighting unit has at least one accessory shoe including a slot and a spring tensioner;

when the first adjacent lighting unit and the second adjacent lighting unit are mechanically connected by the mechanical connector, the first block portion and the second block portion are inserted into the slots of the accessory shoes of the first and second adjacent lighting units respectively and locked by the spring tensioner of the accessory shoe of the first and second adjacent lighting units respectively; and the first and second jackscrews are used to apply loading to the back side of the first and second adjacent lighting units respectively so that the first and second adjacent lighting units are aligned with each other along the second axis.

20. A method for operating the solid-state lighting apparatus according to claim 16, the method comprising:

detection of the presence of adjacent lighting units; setting of DMX addresses of adjacent lighting units; and communication between adjacent lighting units;

wherein the step of detection of the presence of adjacent lighting units comprises:

for each inter-unit communication module:

activating the inter-unit communication module by a microprocessor when a corresponding presence detector detects presence of a corresponding adjacent lighting unit; and

deactivating the inter-unit communication module by the microprocessor when the corresponding presence detector does not detect presence of the corresponding adjacent lighting unit;

wherein the setting of DMX addresses of adjacent lighting units comprises: sequentially setting, by the control communication module, a DMX address for each of the plurality of lighting units when the plurality of solid-state lighting units is working in the chain-effect mode; and

wherein the communication between adjacent lighting units comprises:

receiving, by a control communication module, control signal from a control panel;

decoding, by the control communication module, the control signal into a control command by;

sending, by the control communication module, the control command to the microprocessor;

receiving, by the microprocessor, the control commands from the control communication module; and

sending, by the microprocessor, the control commands to one or more activated optical transceivers to forward the control commands to one or more adjacent lighting units.