



US011846116B2

(12) **United States Patent**
Ager et al.

(10) **Patent No.:** **US 11,846,116 B2**

(45) **Date of Patent:** ***Dec. 19, 2023**

(54) **THEATER HAVING A MODULAR AUDITORIUM AND METHOD FOR ASSEMBLING A THEATER**

(58) **Field of Classification Search**
CPC .. E04H 3/14; E04H 3/22; E04H 3/123; E04H 3/126; E04H 3/142; E04H 3/145;
(Continued)

(71) Applicant: **TAIT TOWERS MANUFACTURING, LLC**, Lititz, PA (US)

(56) **References Cited**

(72) Inventors: **Mark Ager**, London (GB); **Ewart Richardson**, London (GB)

U.S. PATENT DOCUMENTS

(73) Assignee: **Tait Towers Manufacturing, LLC**, Lititz, PA (US)

3,258,146 A 6/1966 Hamilton
3,884,524 A 5/1975 Eberle
(Continued)

(*) Notice: Subject to any disclaimer, the term of this patent is extended or adjusted under 35 U.S.C. 154(b) by 0 days.

This patent is subject to a terminal disclaimer.

FOREIGN PATENT DOCUMENTS

CA 2793598 A1 4/2014
CN 109805659 A 5/2019
(Continued)

OTHER PUBLICATIONS

(21) Appl. No.: **17/940,463**

PCT International Preliminary Report on Patentability, dated Apr. 8, 2020, 8 pgs.

(22) Filed: **Sep. 8, 2022**

(65) **Prior Publication Data**

US 2023/0003041 A1 Jan. 5, 2023

Primary Examiner — Babajide A Demuren

(74) *Attorney, Agent, or Firm* — Saxton & Stump, LLC

Related U.S. Application Data

(63) Continuation of application No. 17/212,587, filed on Mar. 25, 2021, now Pat. No. 11,466,468, which is a
(Continued)

(57) **ABSTRACT**

A method for assembling a theater and a theater. The method includes assembling a modular auditorium on a surface within a building structure by providing a plurality of nominal inventory portions. Each nominal inventory portions includes a prefabricated base portion, and a prefabricated tier section for assembly to the base portion. The prefabricated base portion is positioned on a ground surface of a public performance space. The prefabricated tier section is fastened to the prefabricated base portion to form a self supporting structure that does not require lateral support from a building structure other than the ground surface.

(51) **Int. Cl.**
E04H 3/12 (2006.01)
A47C 1/12 (2006.01)
(Continued)

(52) **U.S. Cl.**
CPC *E04H 3/126* (2013.01); *A47C 1/12* (2013.01); *E04H 3/12* (2013.01); *E04H 3/30* (2013.01);
(Continued)

22 Claims, 36 Drawing Sheets

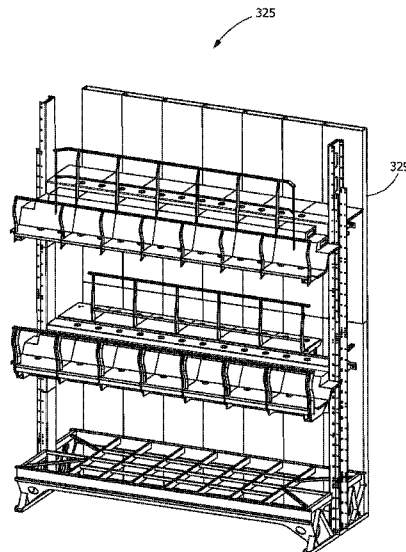

Related U.S. Application Data

- continuation of application No. 16/685,212, filed on Nov. 15, 2019, now Pat. No. 11,066,840, which is a continuation of application No. 15/723,563, filed on Oct. 3, 2017, now Pat. No. 10,513,861.
- (60) Provisional application No. 62/410,088, filed on Oct. 19, 2016.
- (51) **Int. Cl.**
E04H 3/30 (2006.01)
E04H 3/14 (2006.01)
- (52) **U.S. Cl.**
 CPC .. *E04H 2003/145* (2013.01); *E04H 2003/147* (2013.01)
- (58) **Field of Classification Search**
 CPC *E04H 3/147*; *A63G 2200/00*; *A63G 27/02*; *A63G 9/08*
 See application file for complete search history.

5,277,001	A *	1/1994	Bryant	E04H 3/123 52/9
5,660,000	A	8/1997	MacIntyre	
5,809,906	A	9/1998	Janek	
6,138,427	A	10/2000	Houghton	
8,926,440	B2	1/2015	Jacobi	
9,163,420	B2	10/2015	Behague et al.	
9,809,987	B2 *	11/2017	Koch	A47C 1/121
9,828,224	B1	11/2017	Hamilton	
10,046,884	B1	8/2018	Erschen et al.	
2002/0078633	A1	6/2002	Jines et al.	
2003/0046875	A1	3/2003	Ortner	
2006/0086881	A1	4/2006	Miller	
2008/0190038	A1	8/2008	Jacobs et al.	
2013/0123030	A1	5/2013	Jacobi	
2015/0273348	A1	10/2015	Job et al.	
2016/0325201	A1	11/2016	Li et al.	
2017/0226761	A1	8/2017	Phillips	
2017/0234021	A1	8/2017	de Lespinois et al.	
2018/0130565	A1	5/2018	Lehnert et al.	
2020/0386038	A1	12/2020	Salentine et al.	

FOREIGN PATENT DOCUMENTS

- (56) **References Cited**
- U.S. PATENT DOCUMENTS
- | | | | |
|-----------|---|--------|--------|
| 4,367,612 | A | 1/1983 | Sutter |
| 4,669,949 | A | 6/1987 | Sutton |
| 5,188,566 | A | 2/1993 | Bohme |

DE	8914828	U1	4/1991
DE	19818538	A	11/1999
FR	3002778	A1	9/2014
WO	9113661	A1	9/1991
WO	2007057171	A2	5/2007

* cited by examiner

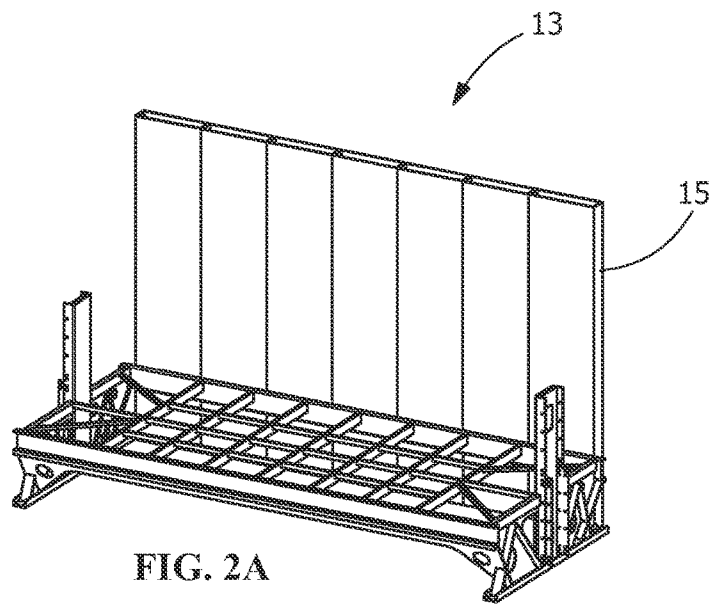
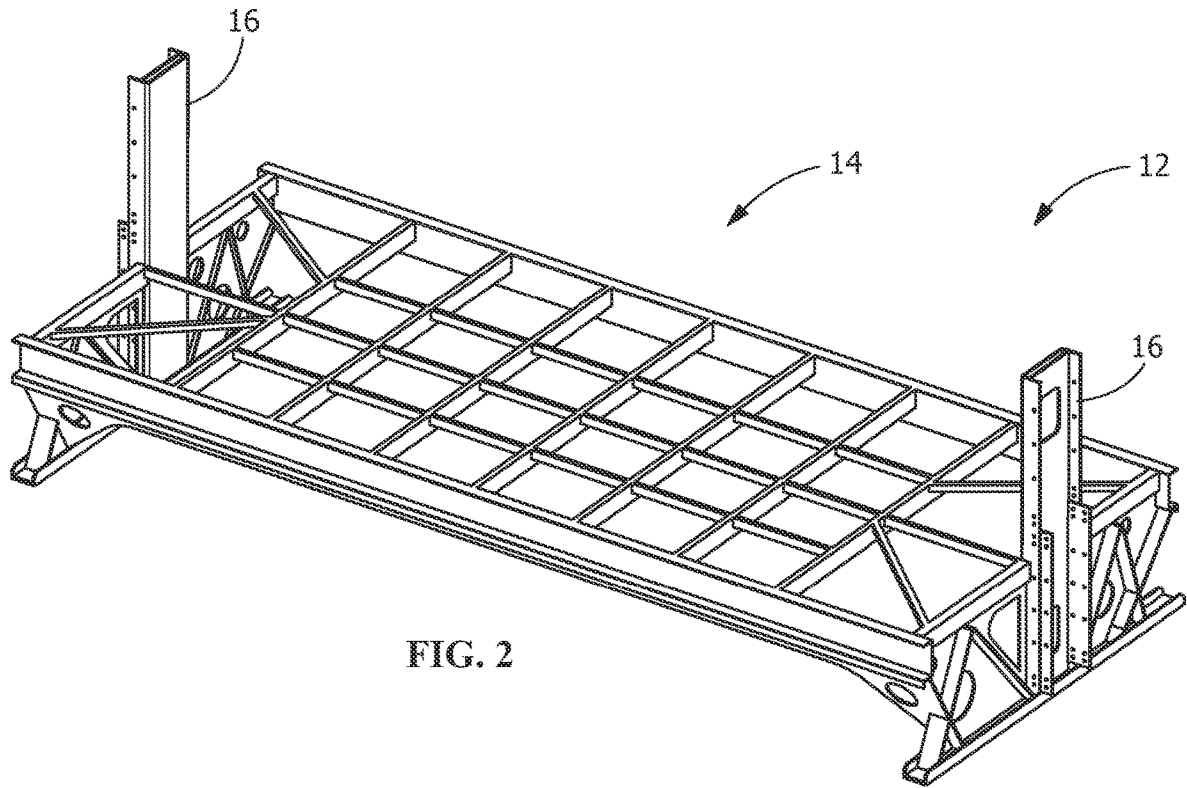

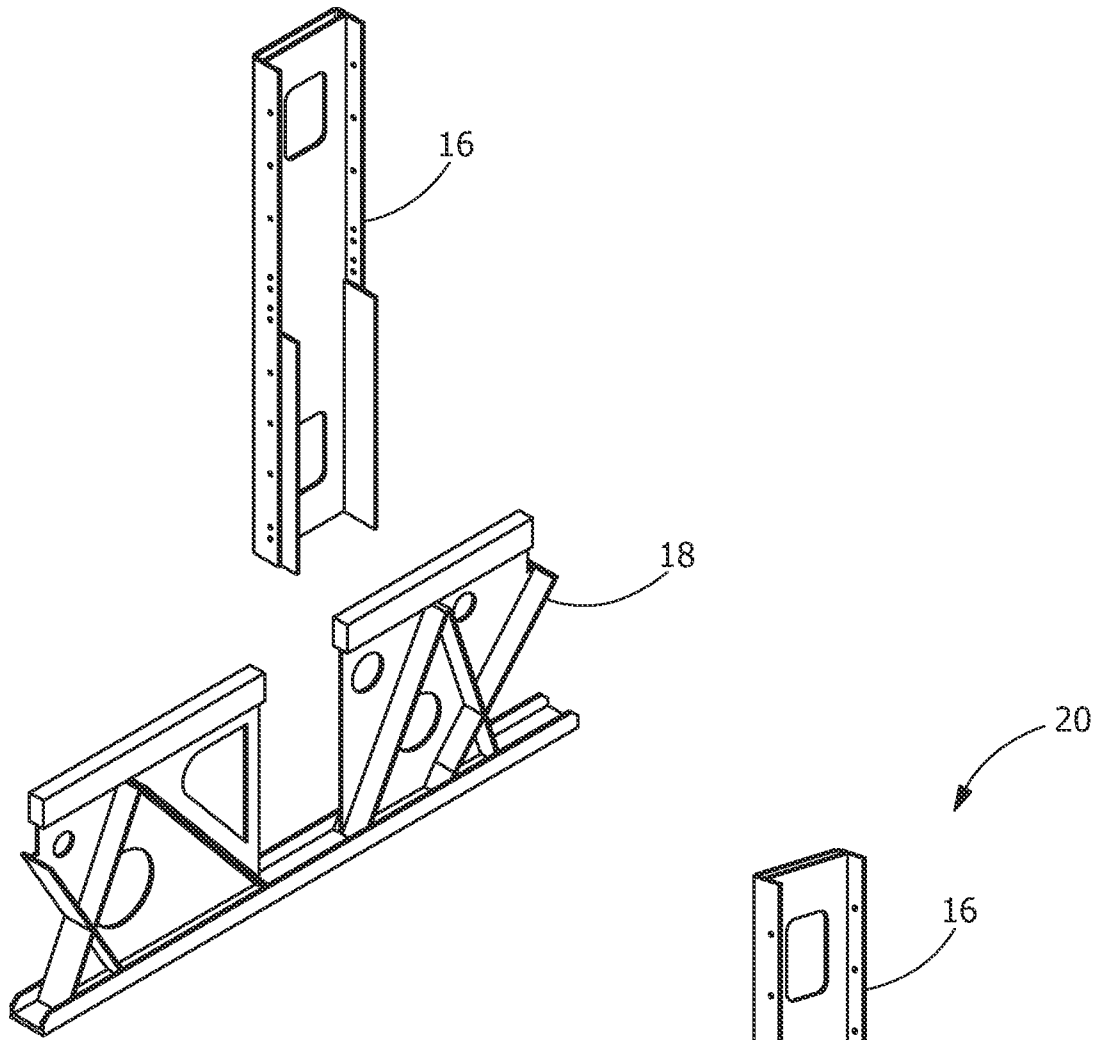

FIG. 3

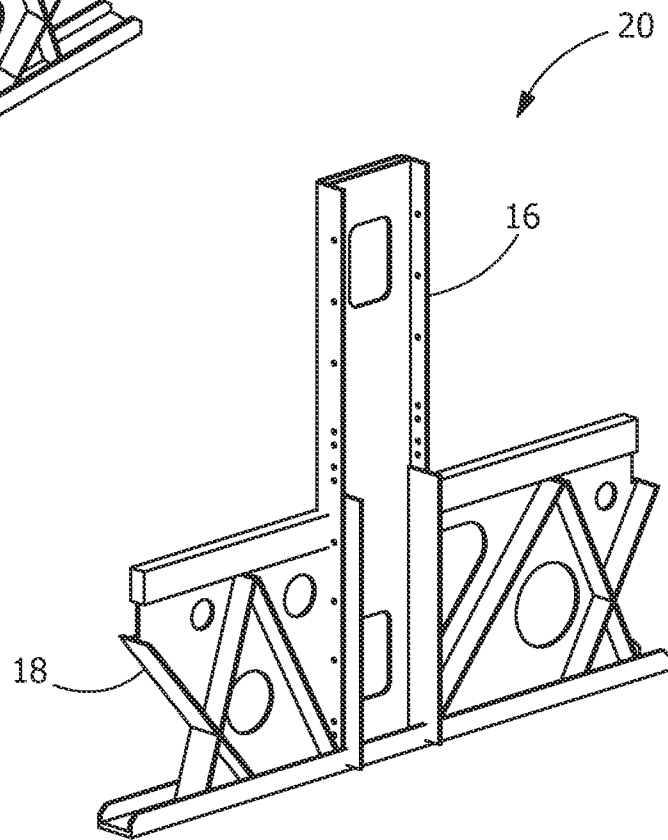
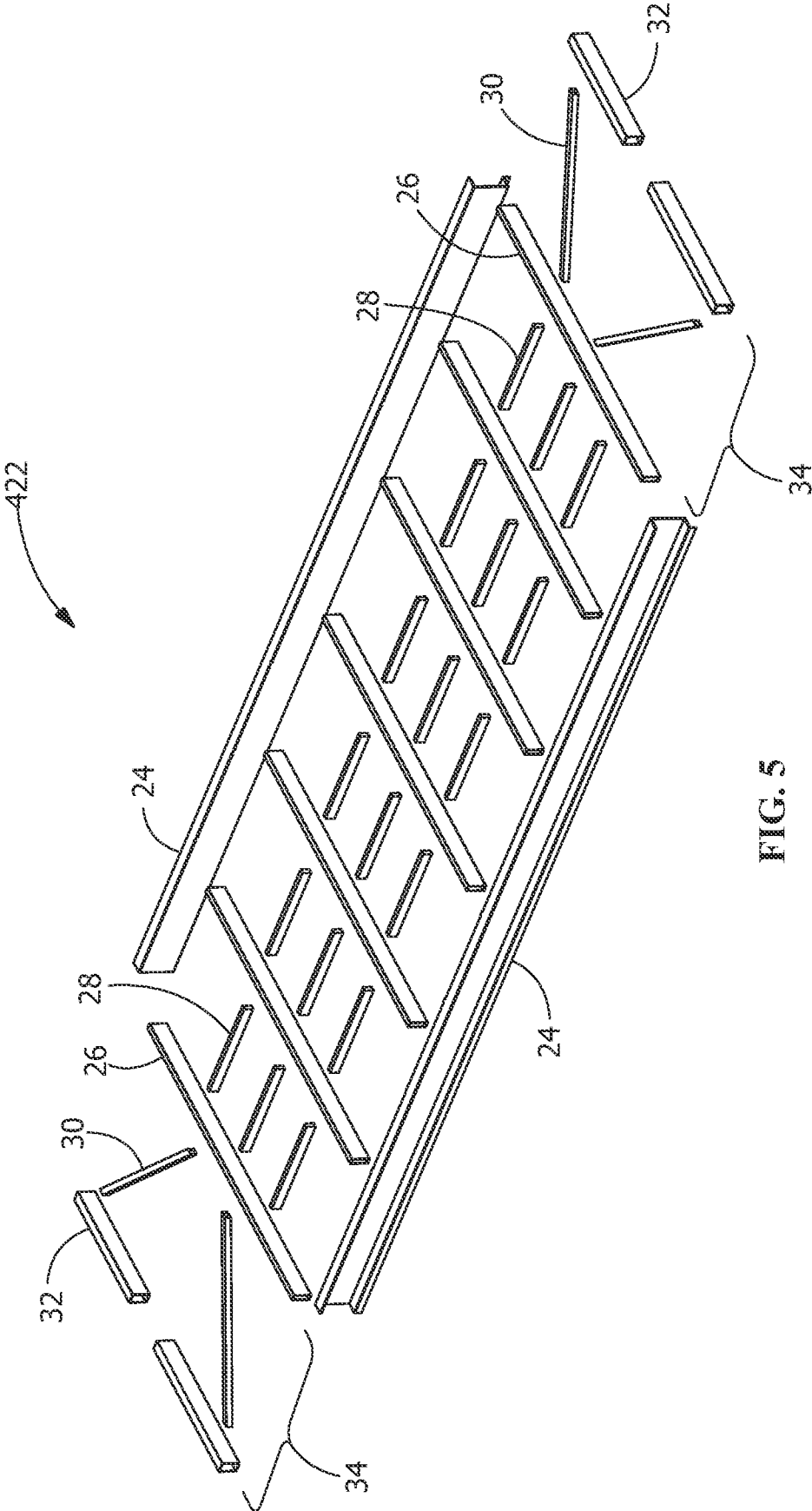

FIG. 4



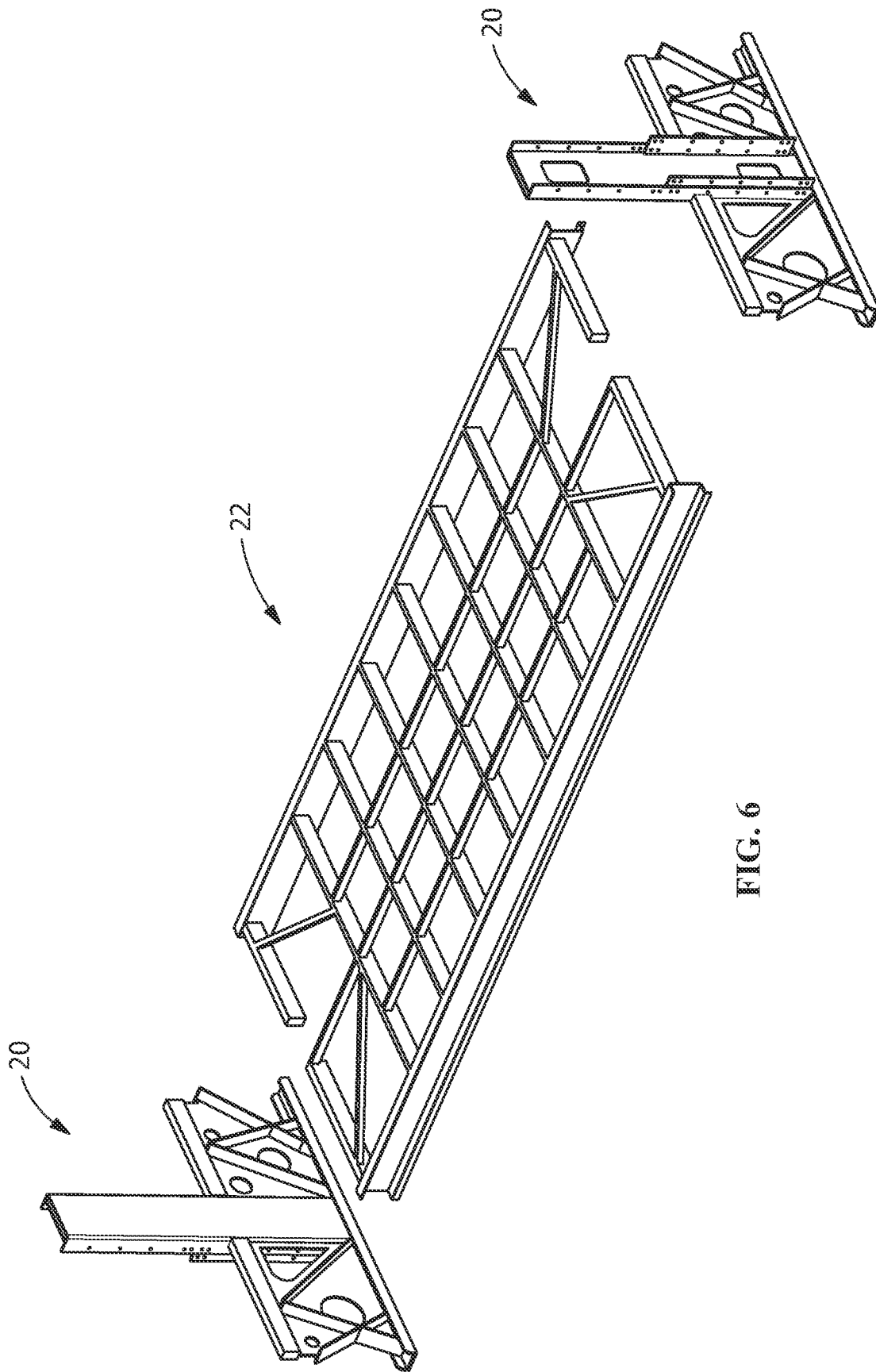

FIG. 6

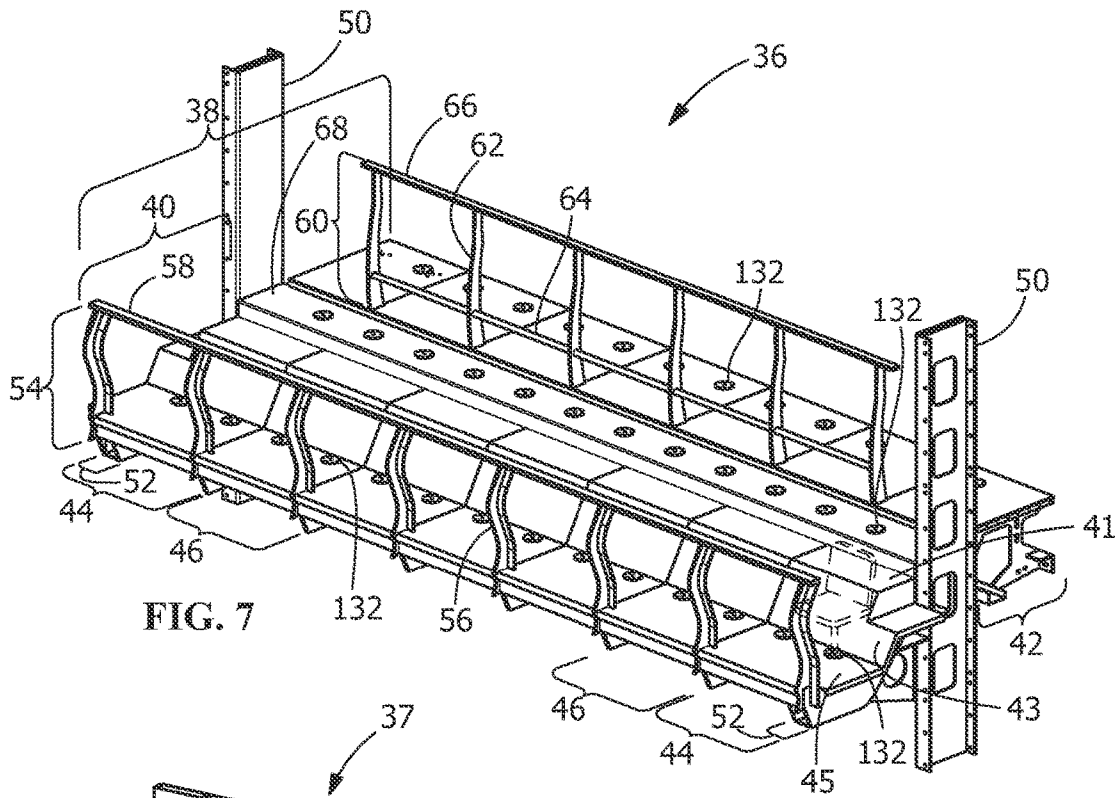

FIG. 7

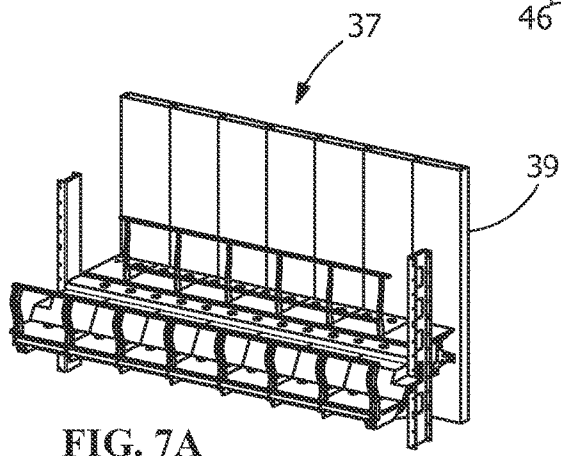

FIG. 7A

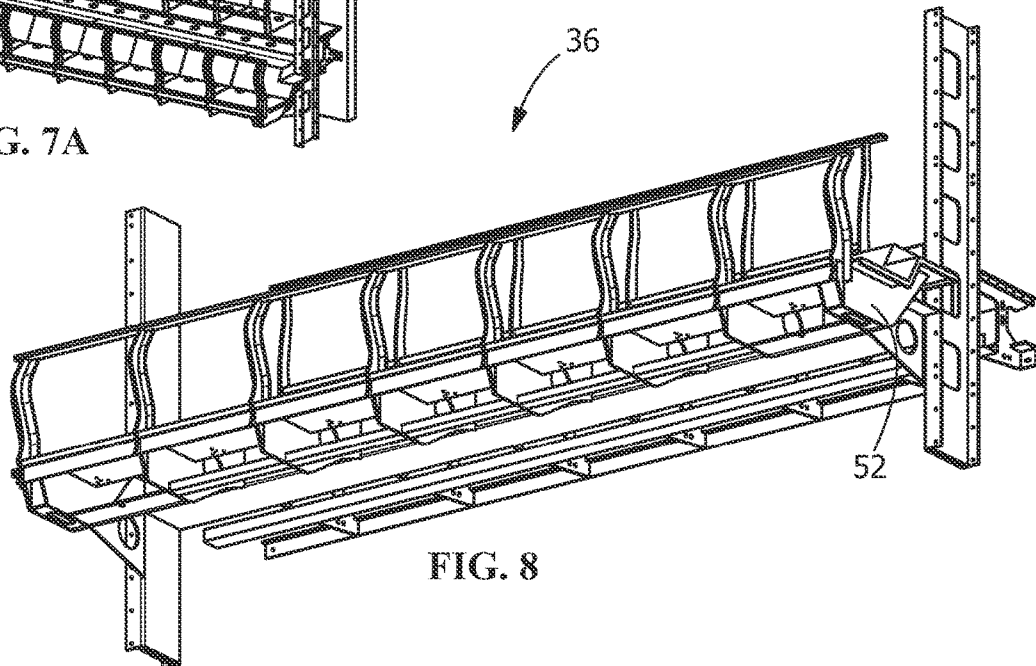

FIG. 8

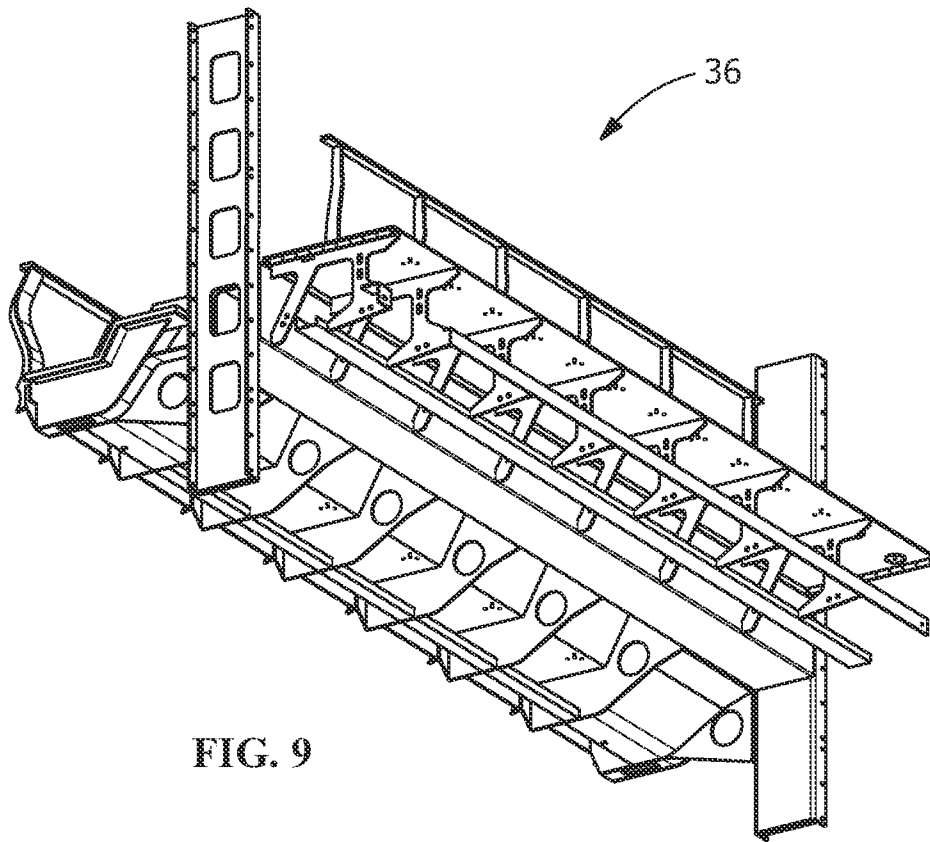

FIG. 9

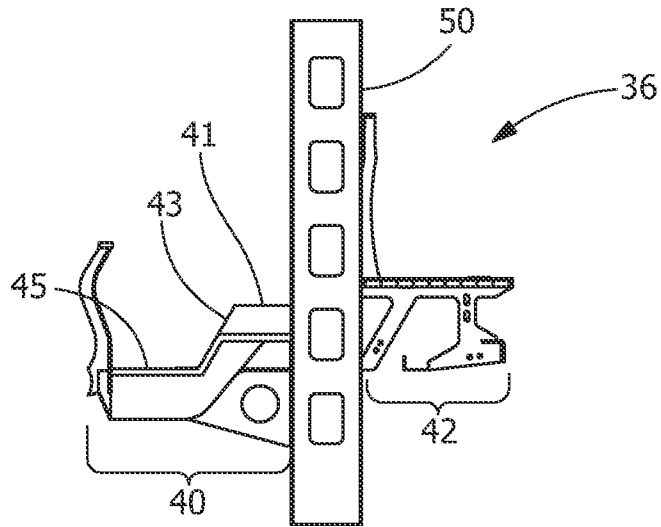

FIG. 10

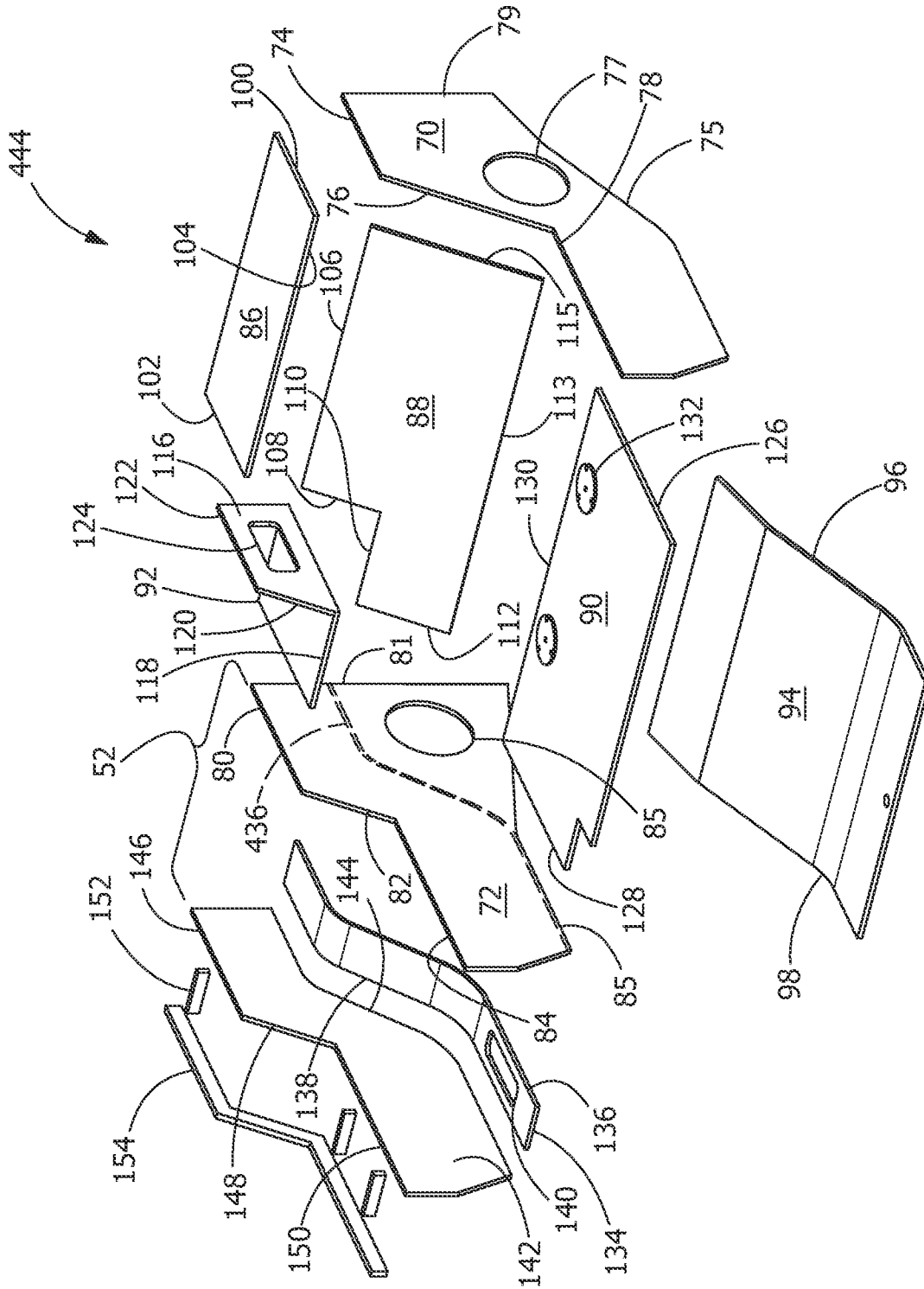

FIG. 11

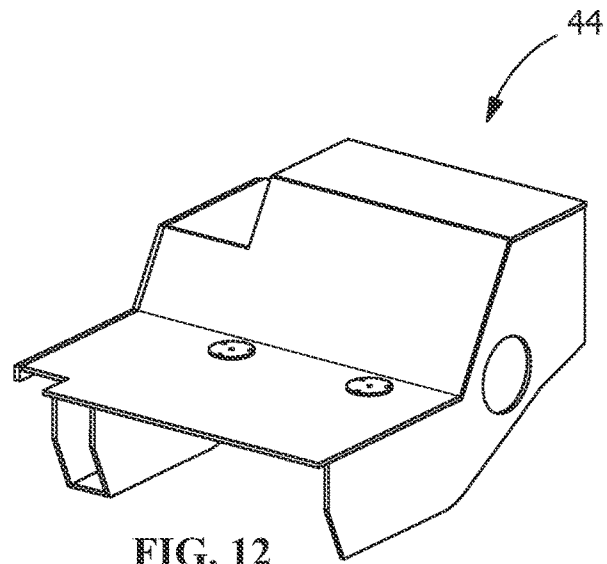

FIG. 12

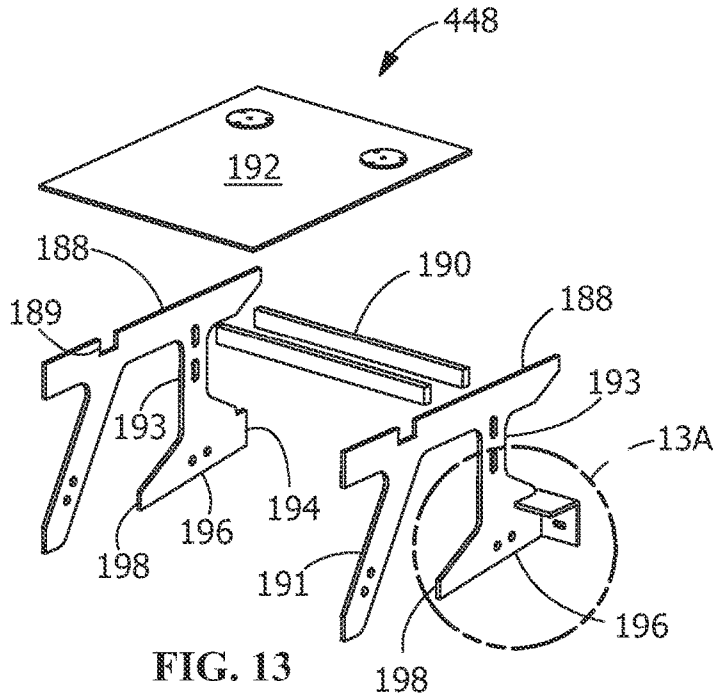

FIG. 13

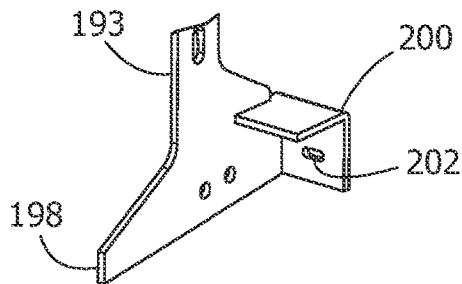

FIG. 13A

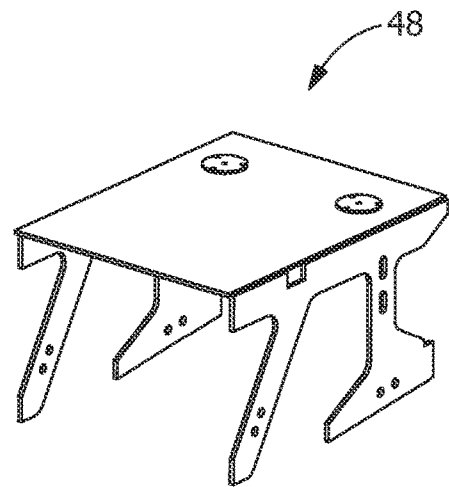

FIG. 14

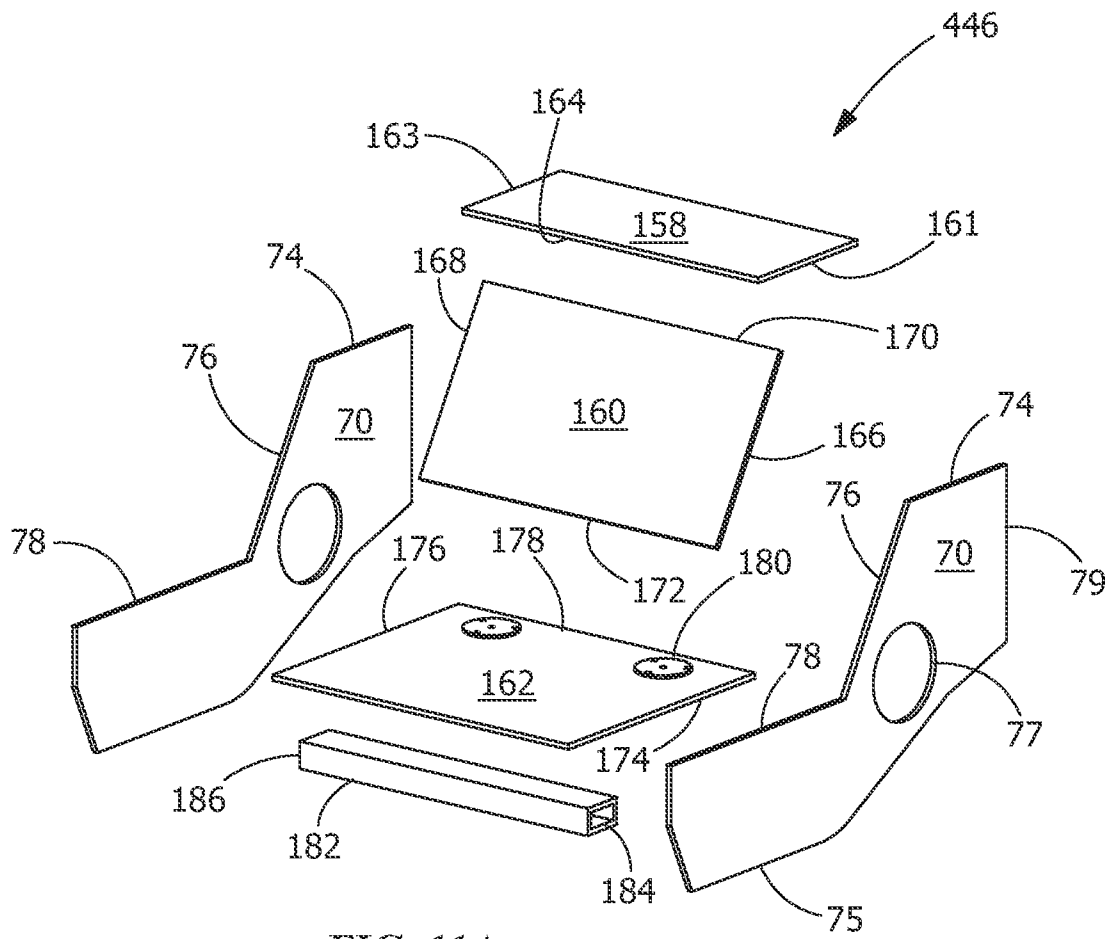

FIG. 11A

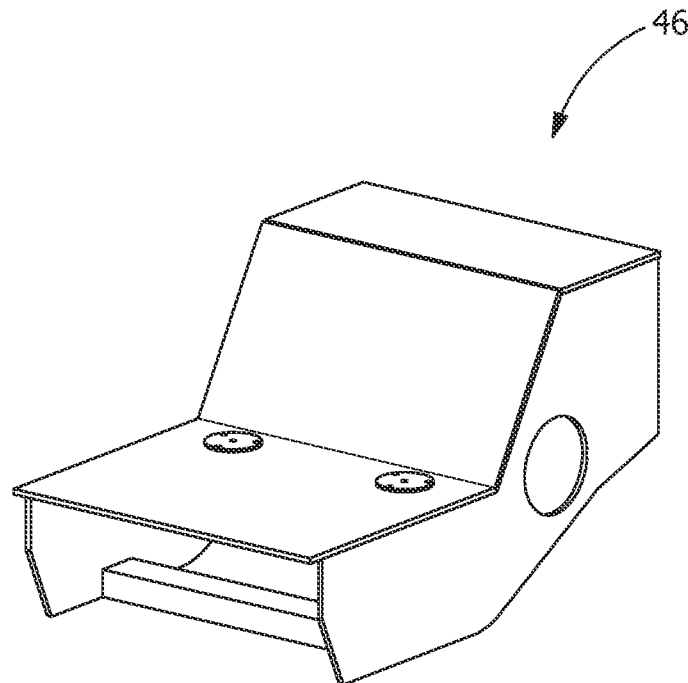

FIG. 12A

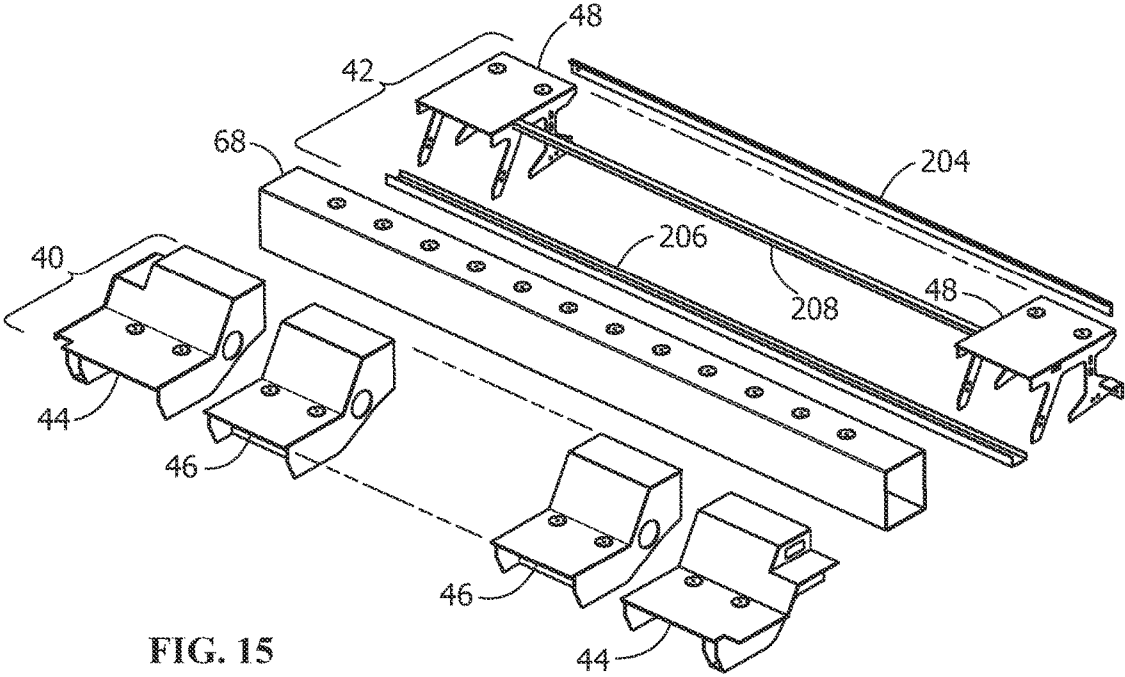

FIG. 15

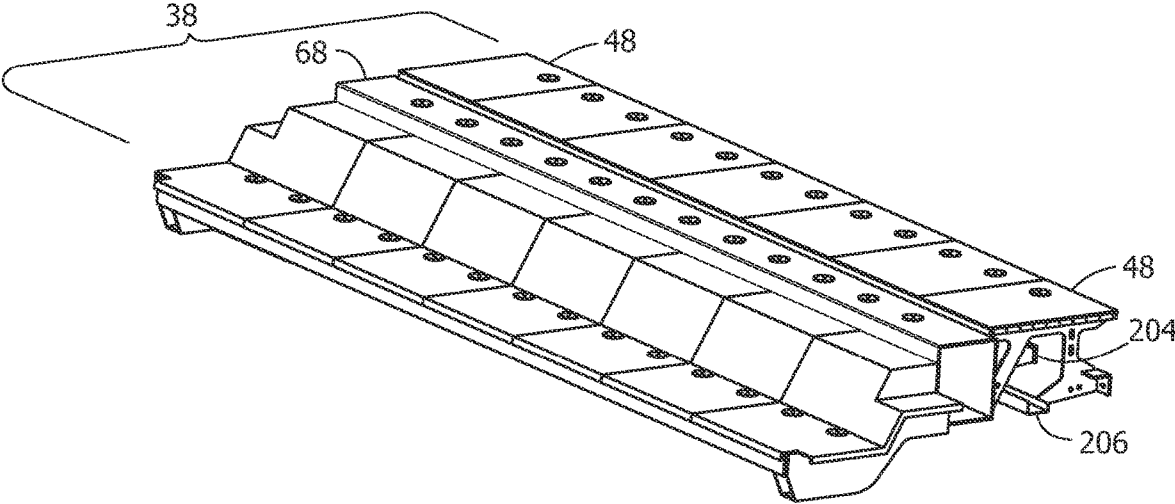

FIG. 16

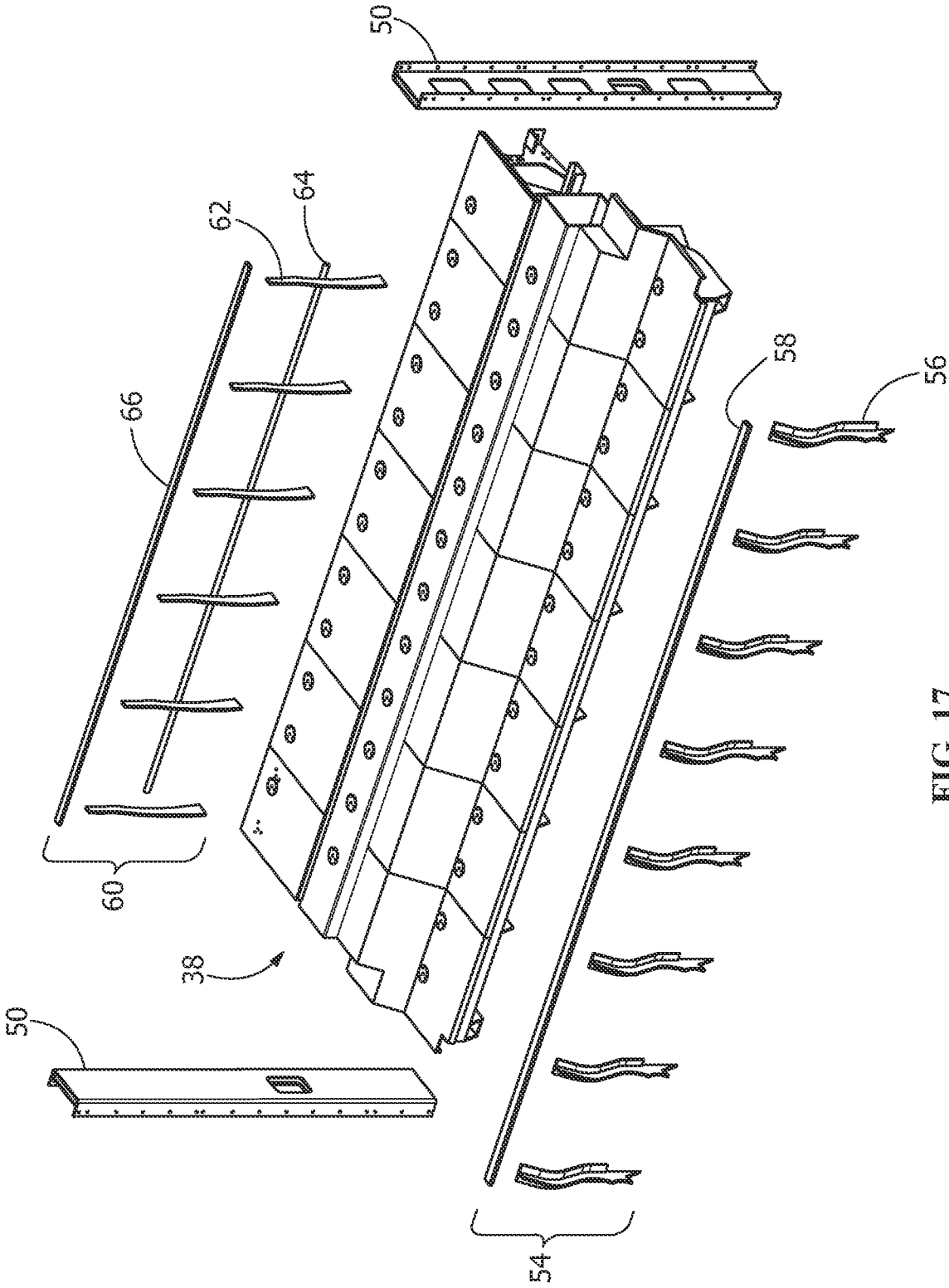
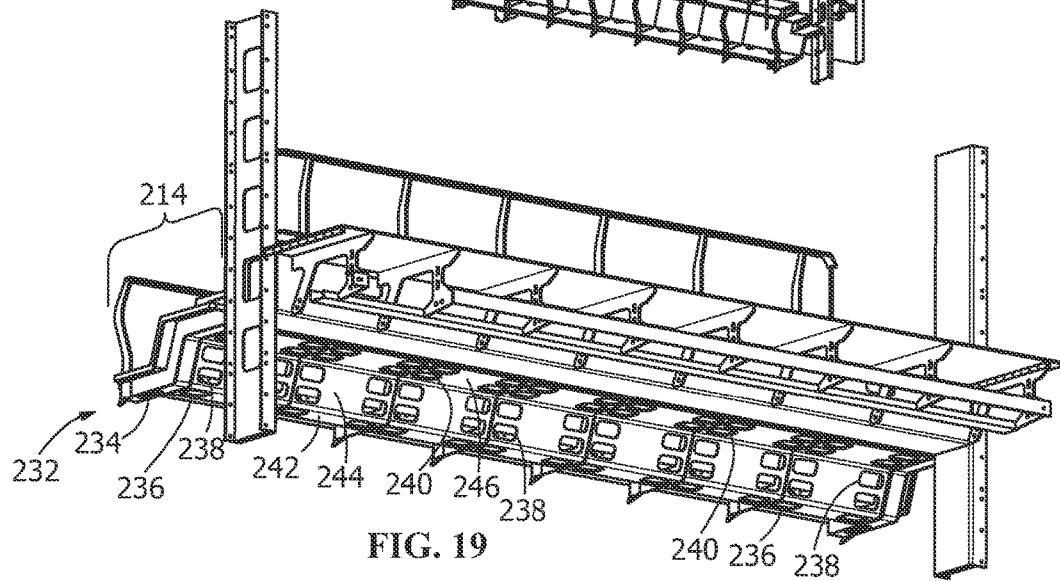
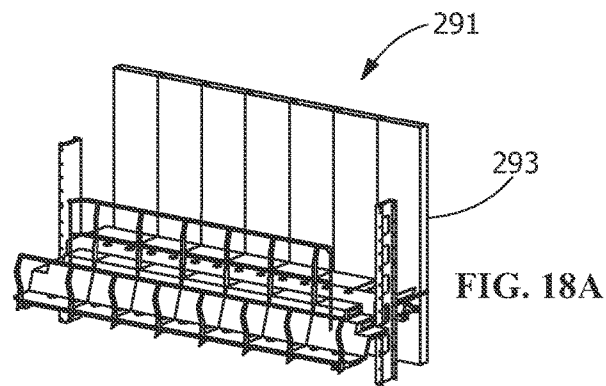
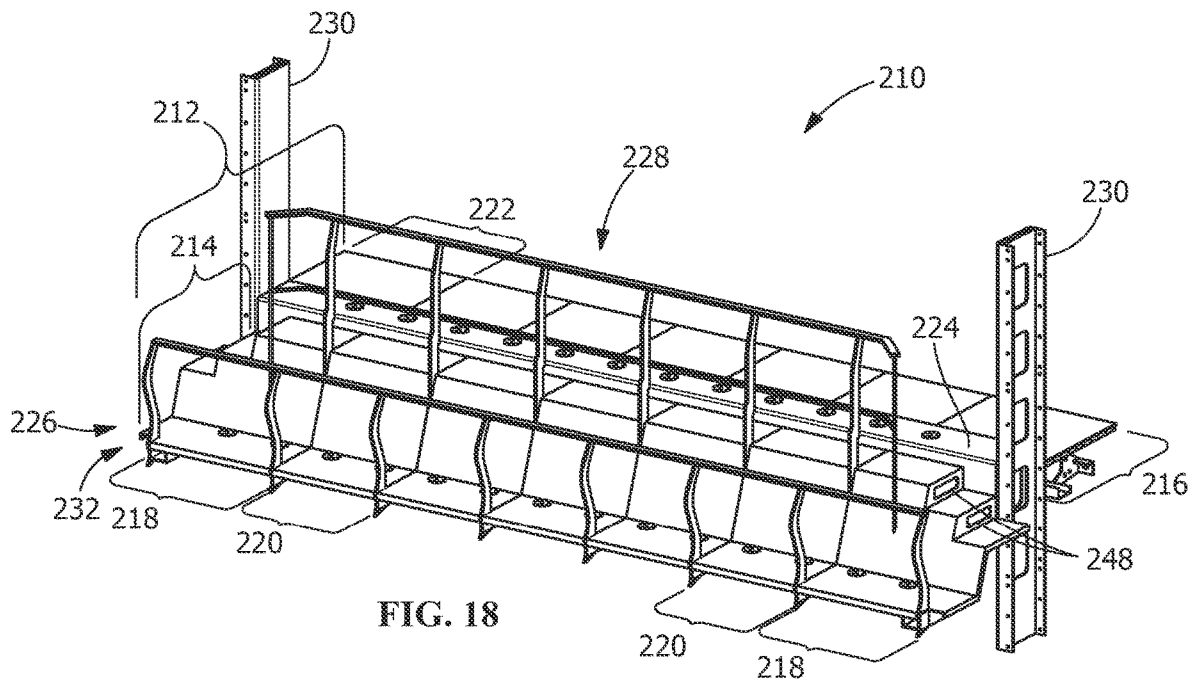

FIG. 17



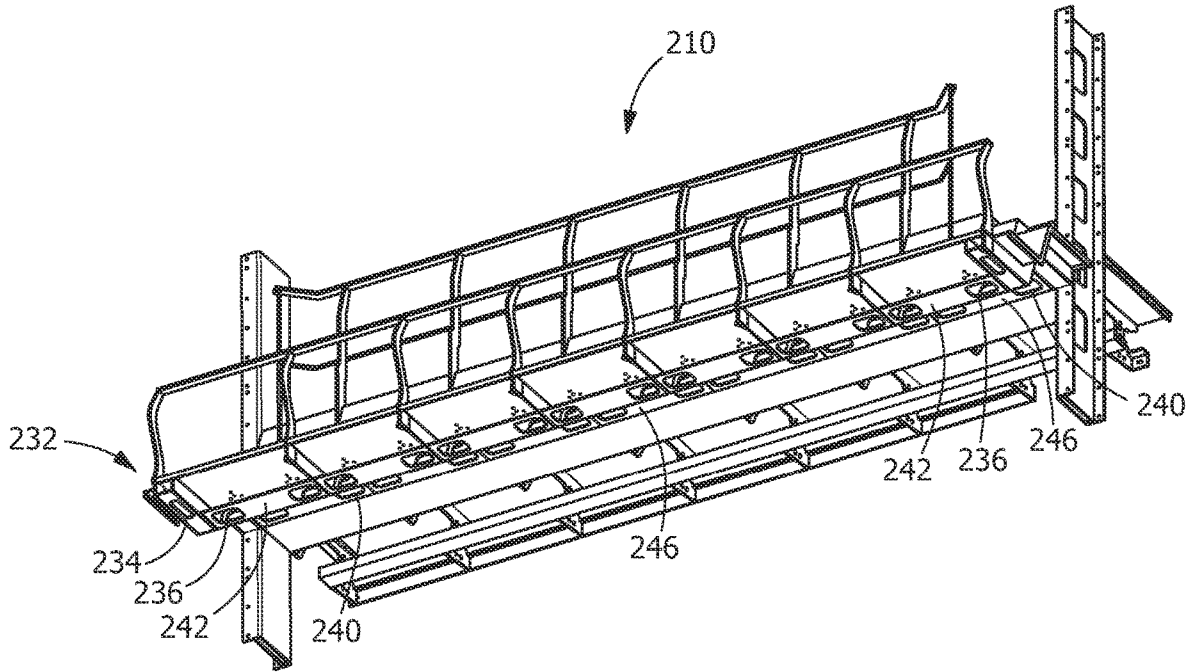

FIG. 20

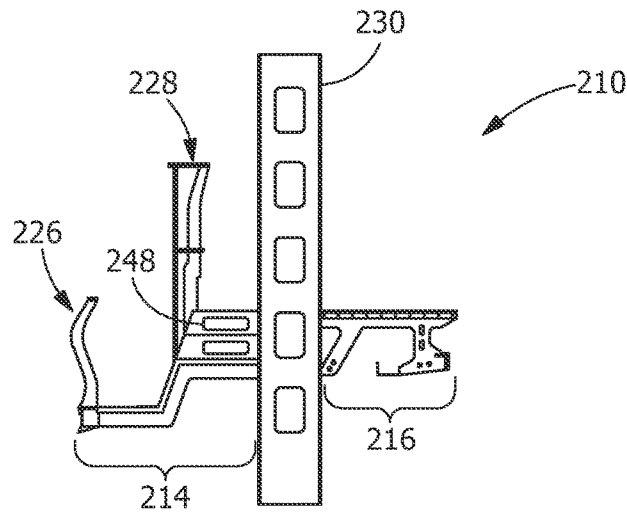

FIG. 21

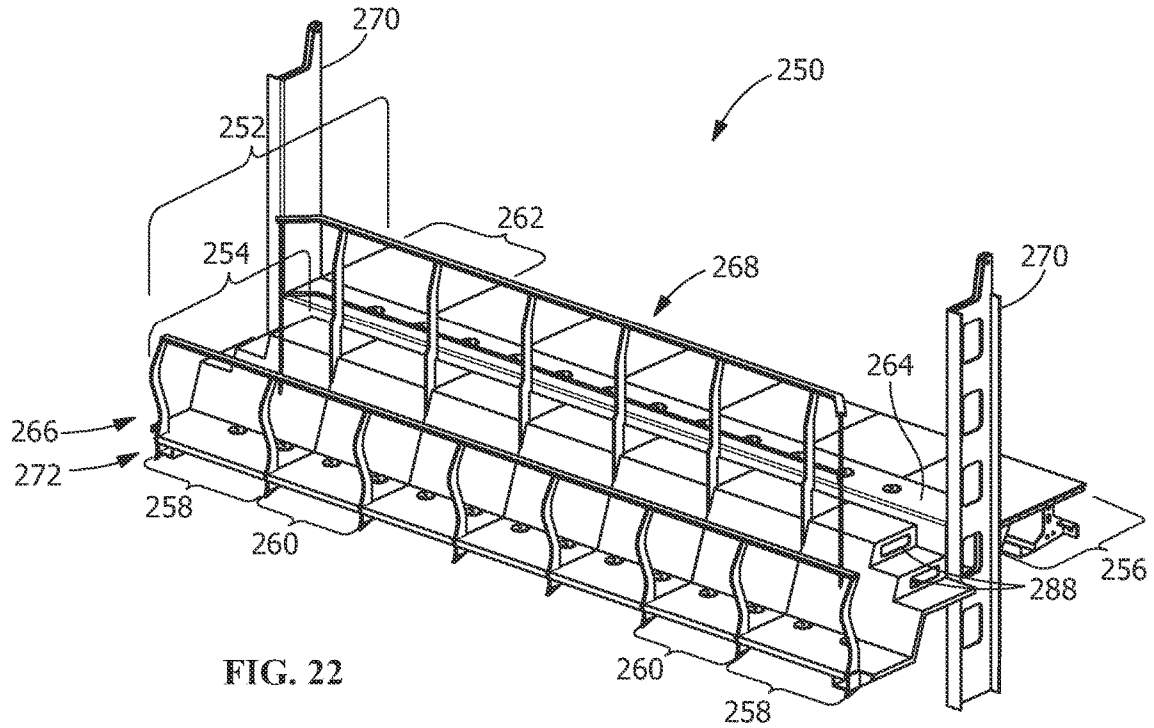

FIG. 22

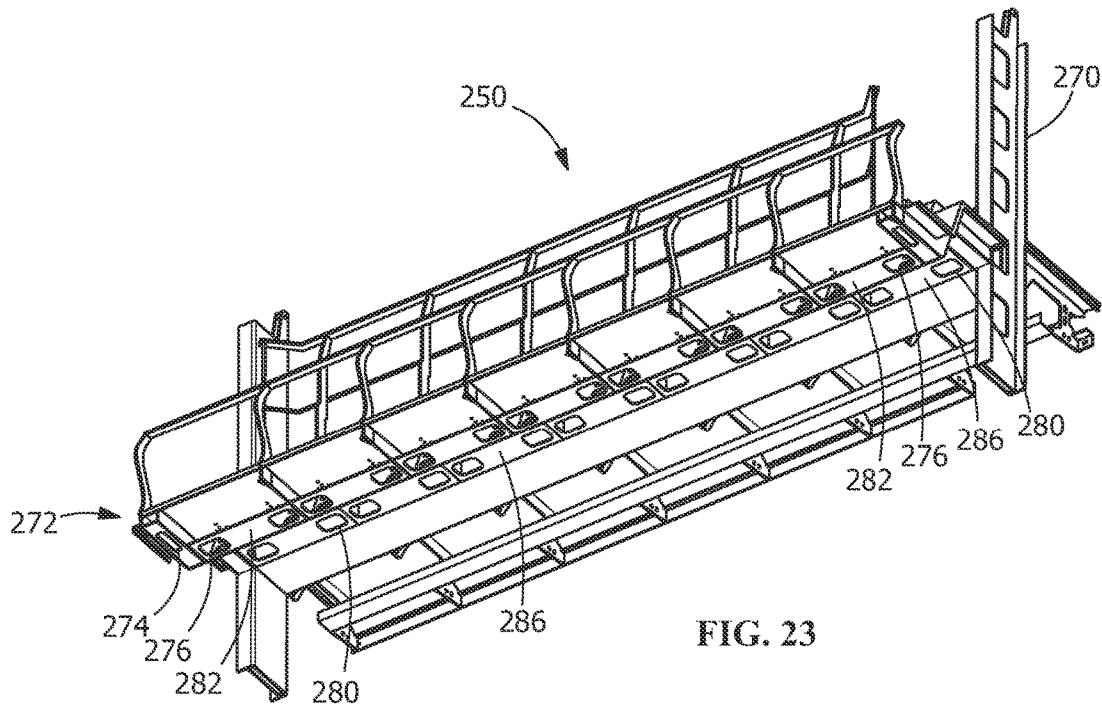

FIG. 23

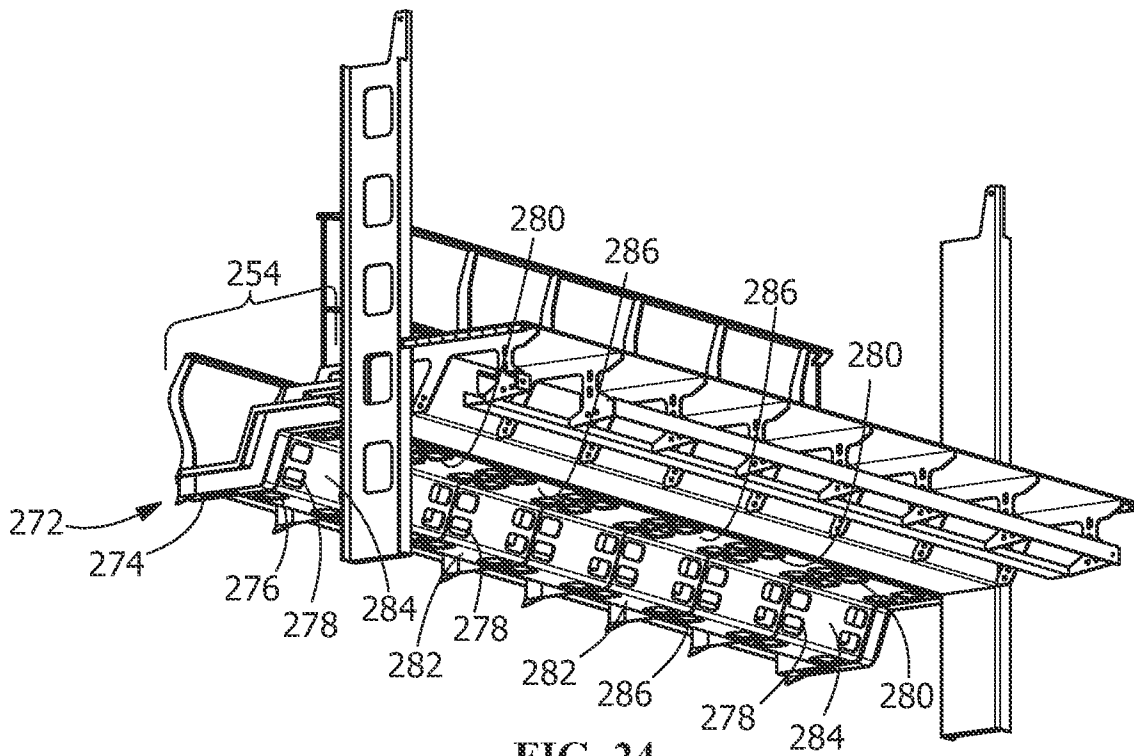

FIG. 24

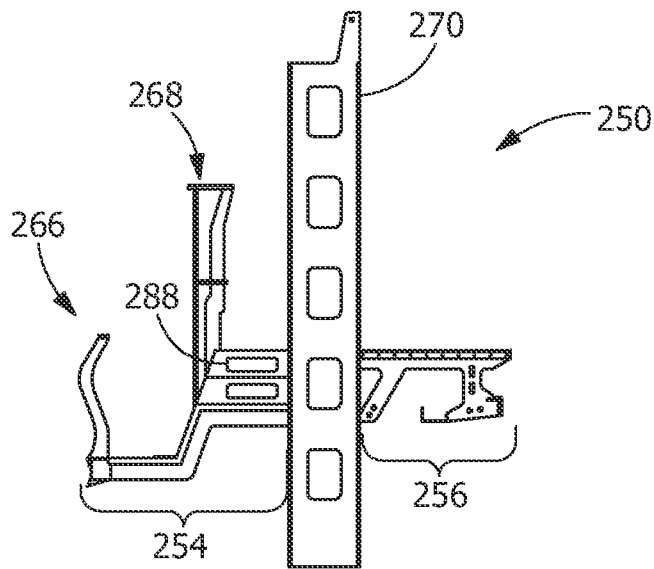

FIG. 25

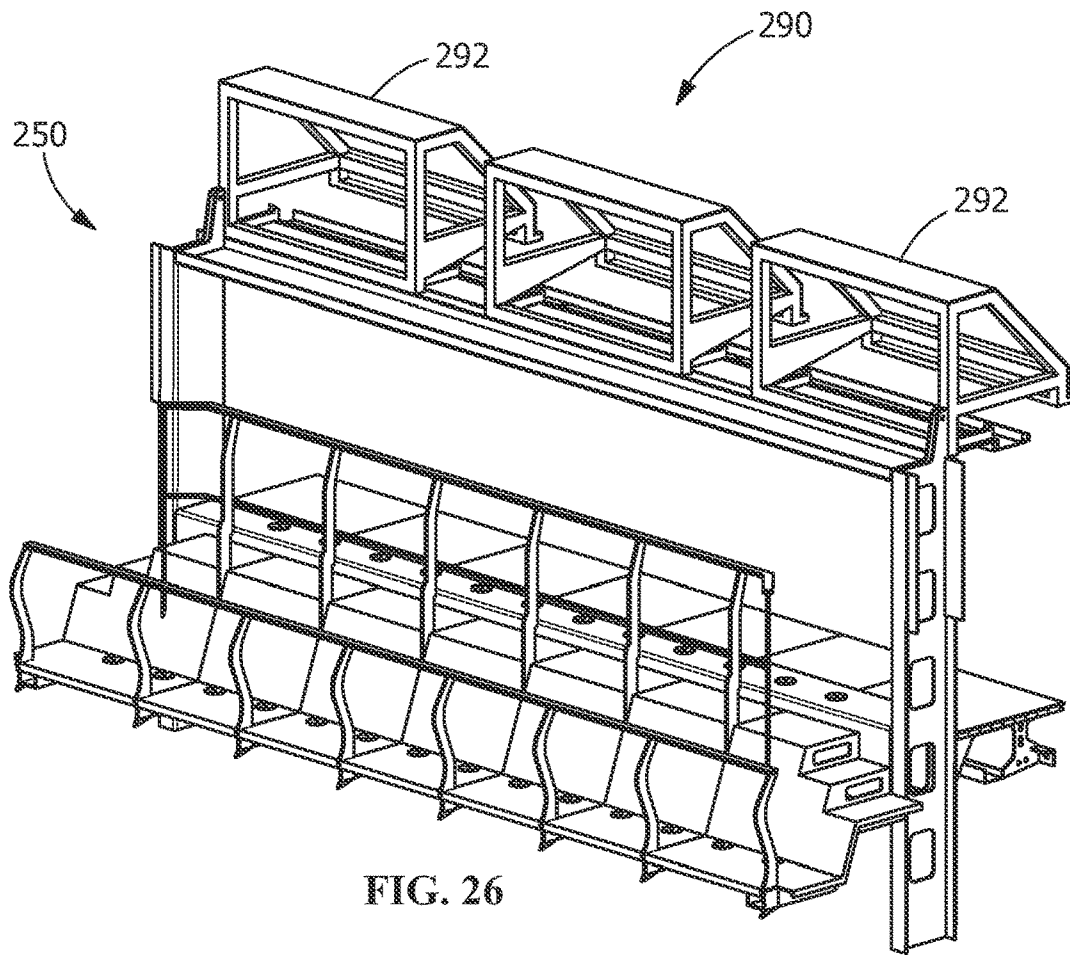

FIG. 26

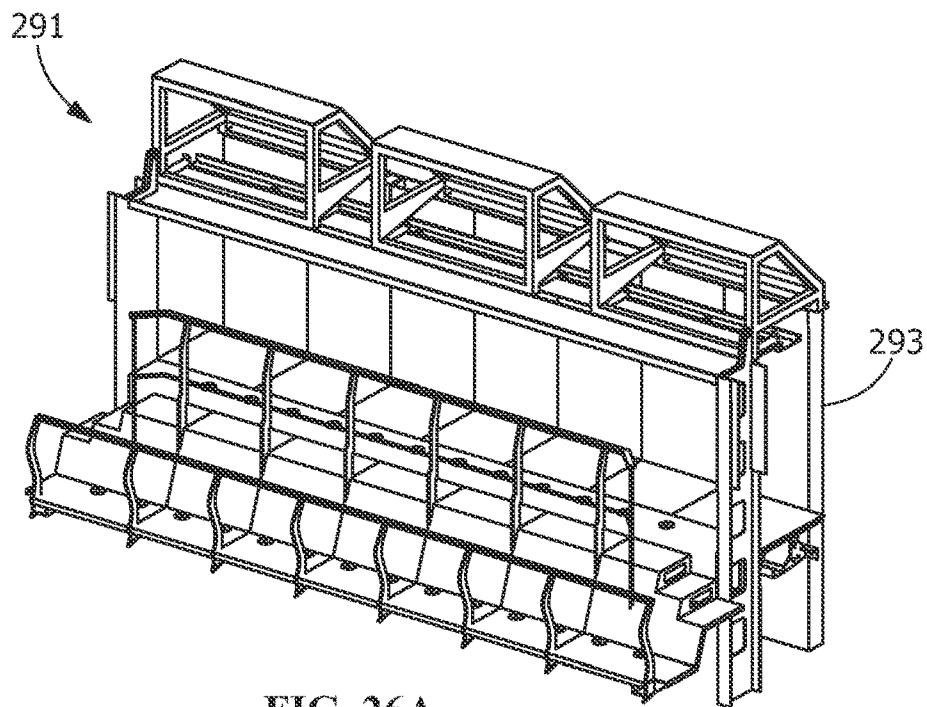

FIG. 26A

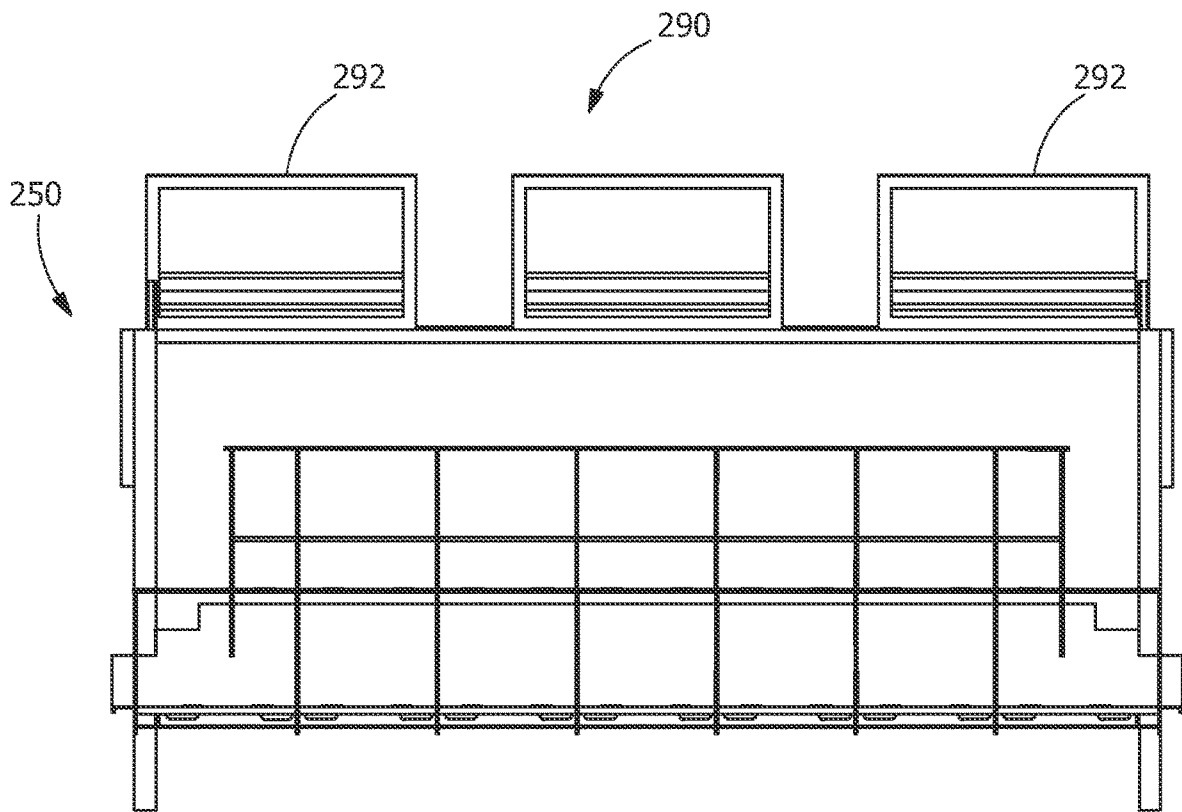
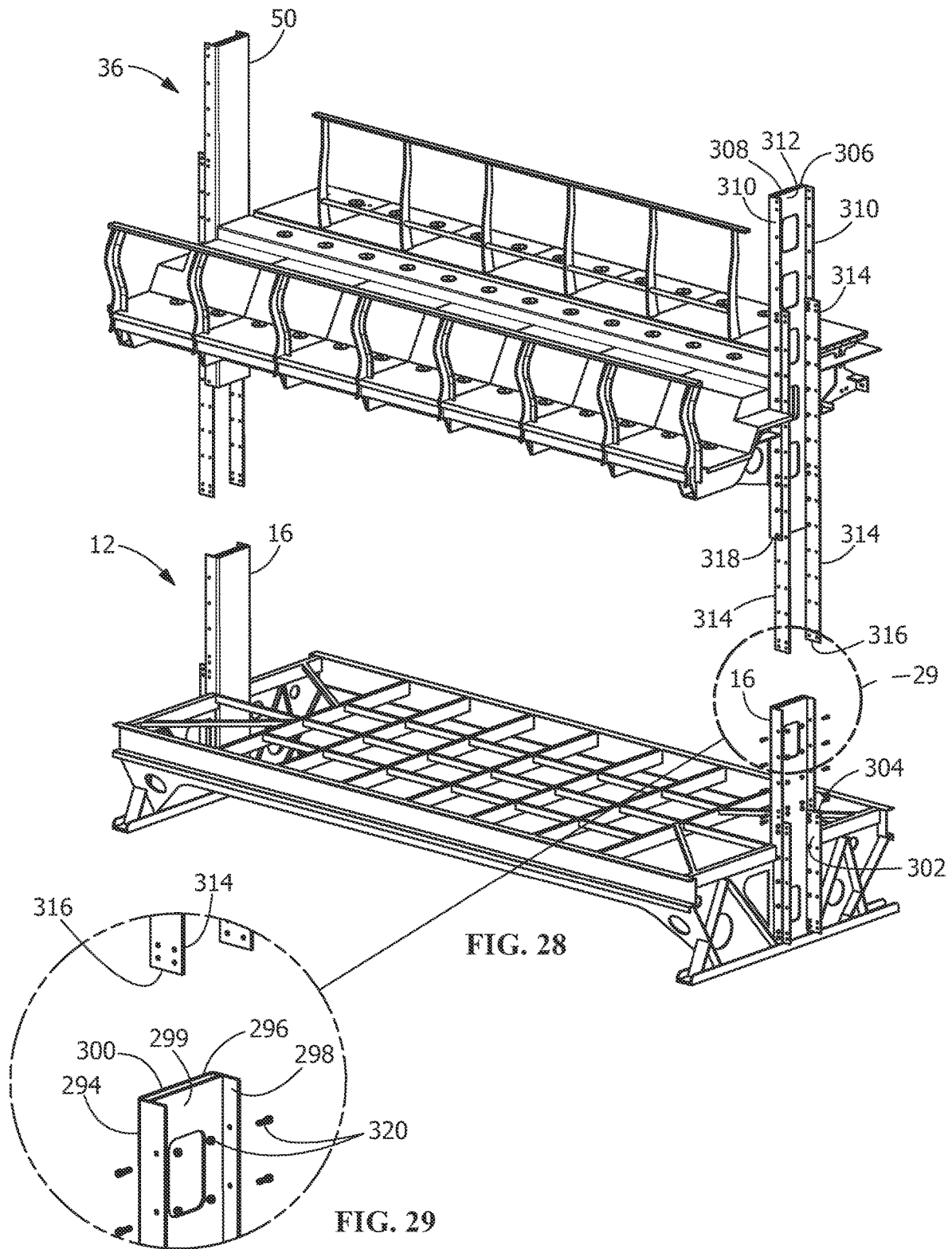

FIG. 27



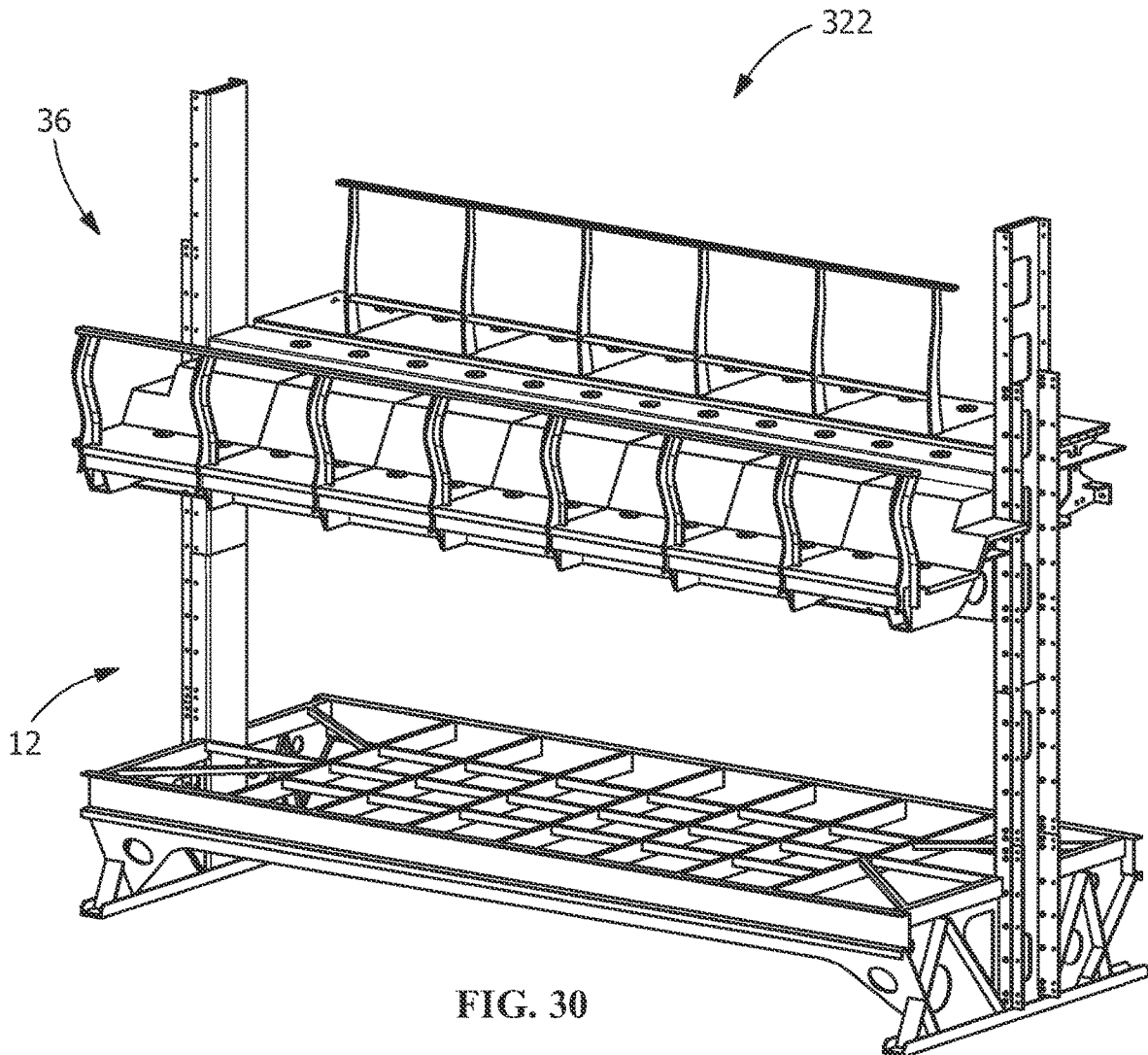

FIG. 30

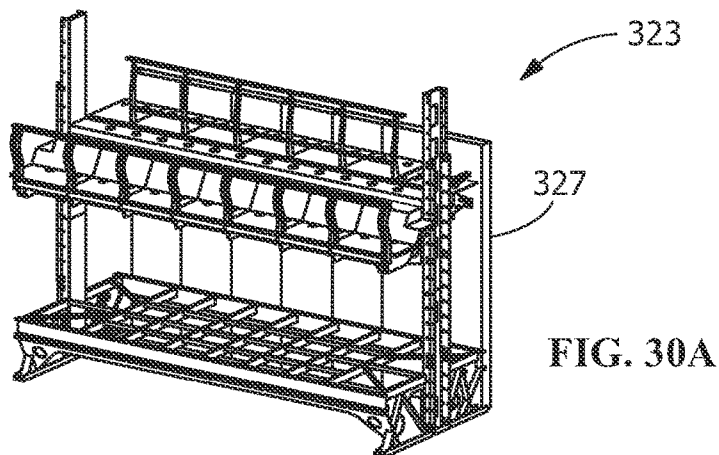

FIG. 30A

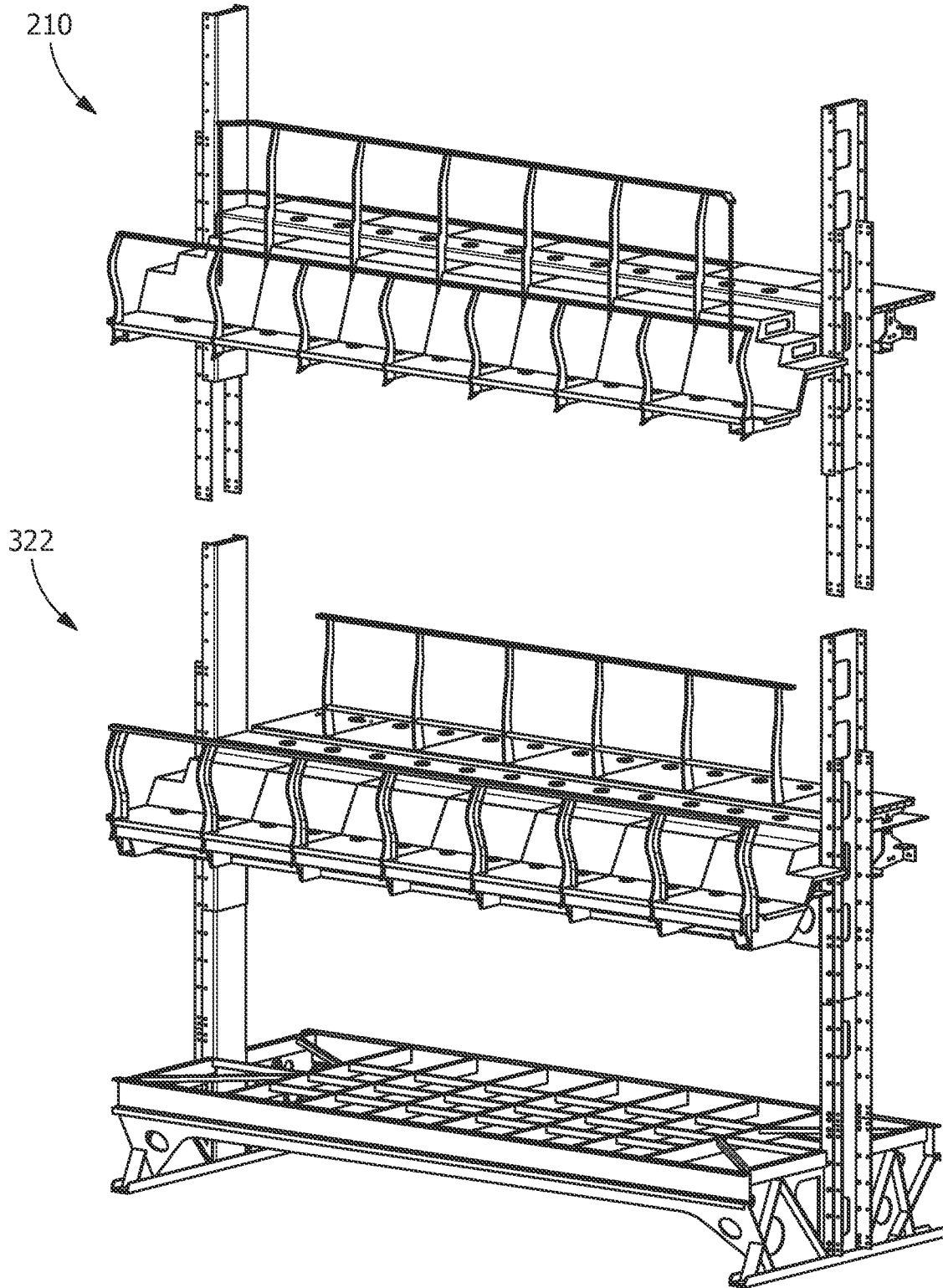

FIG. 31

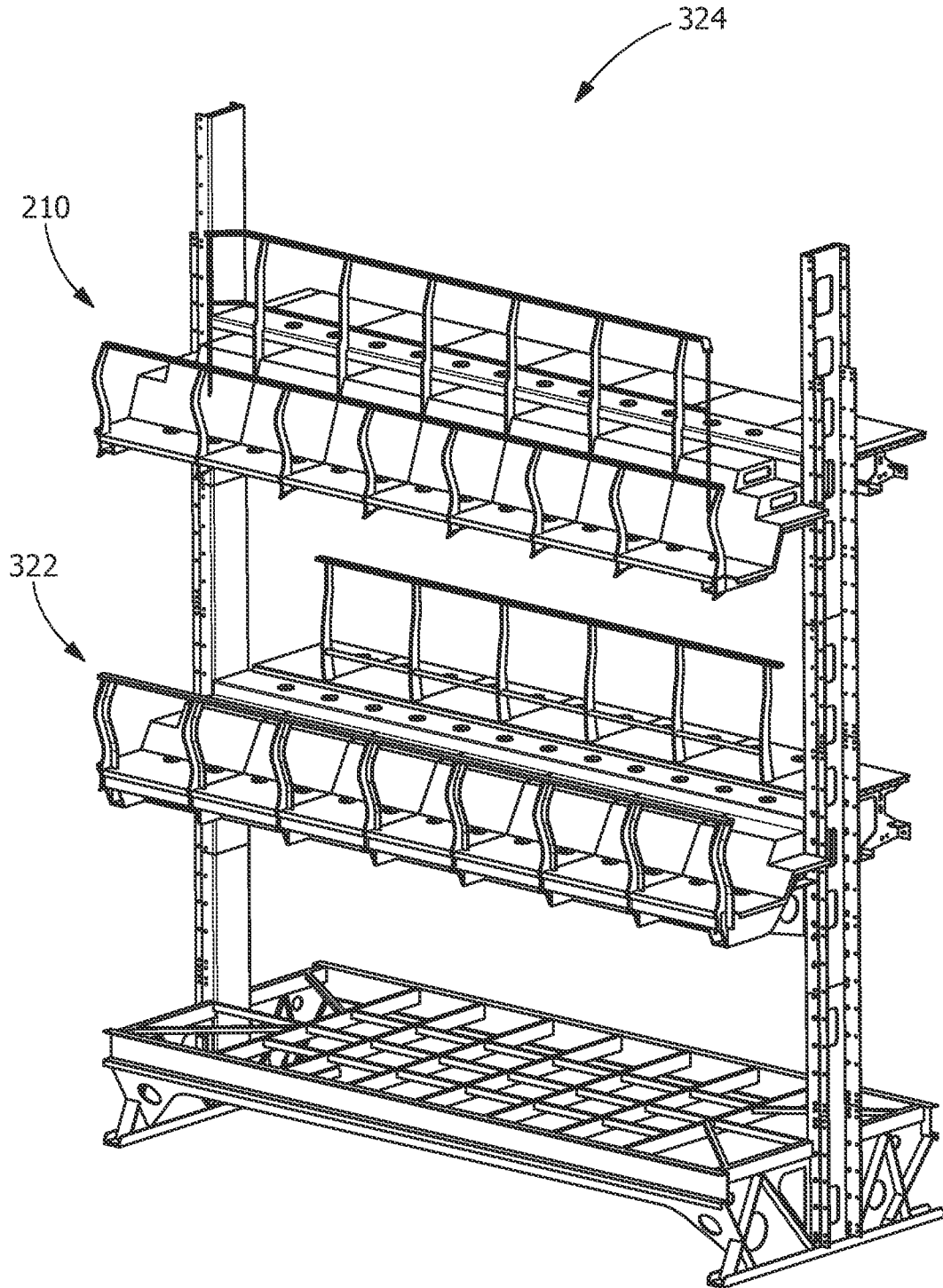

FIG. 32

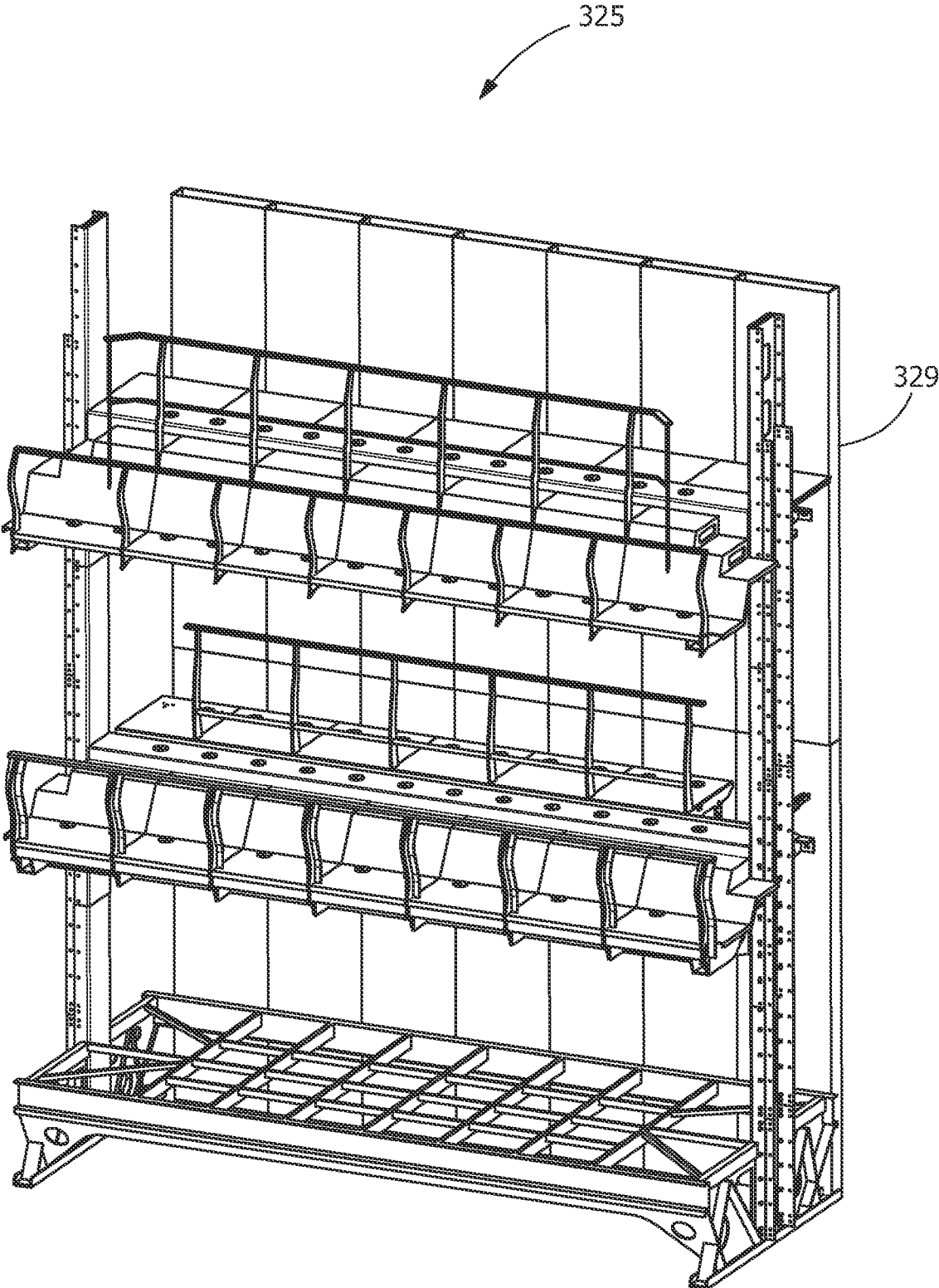

FIG. 32A

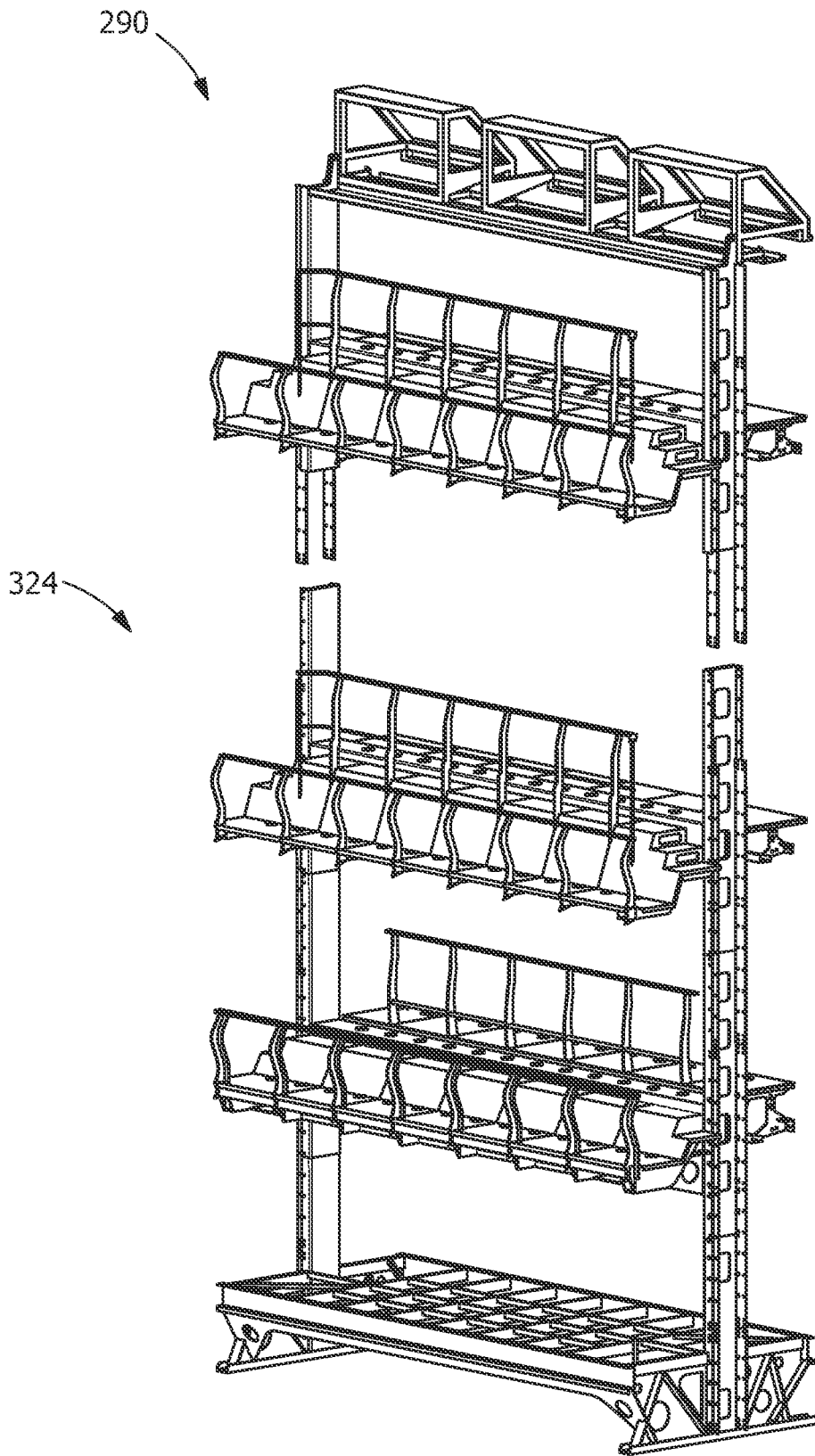

FIG. 33

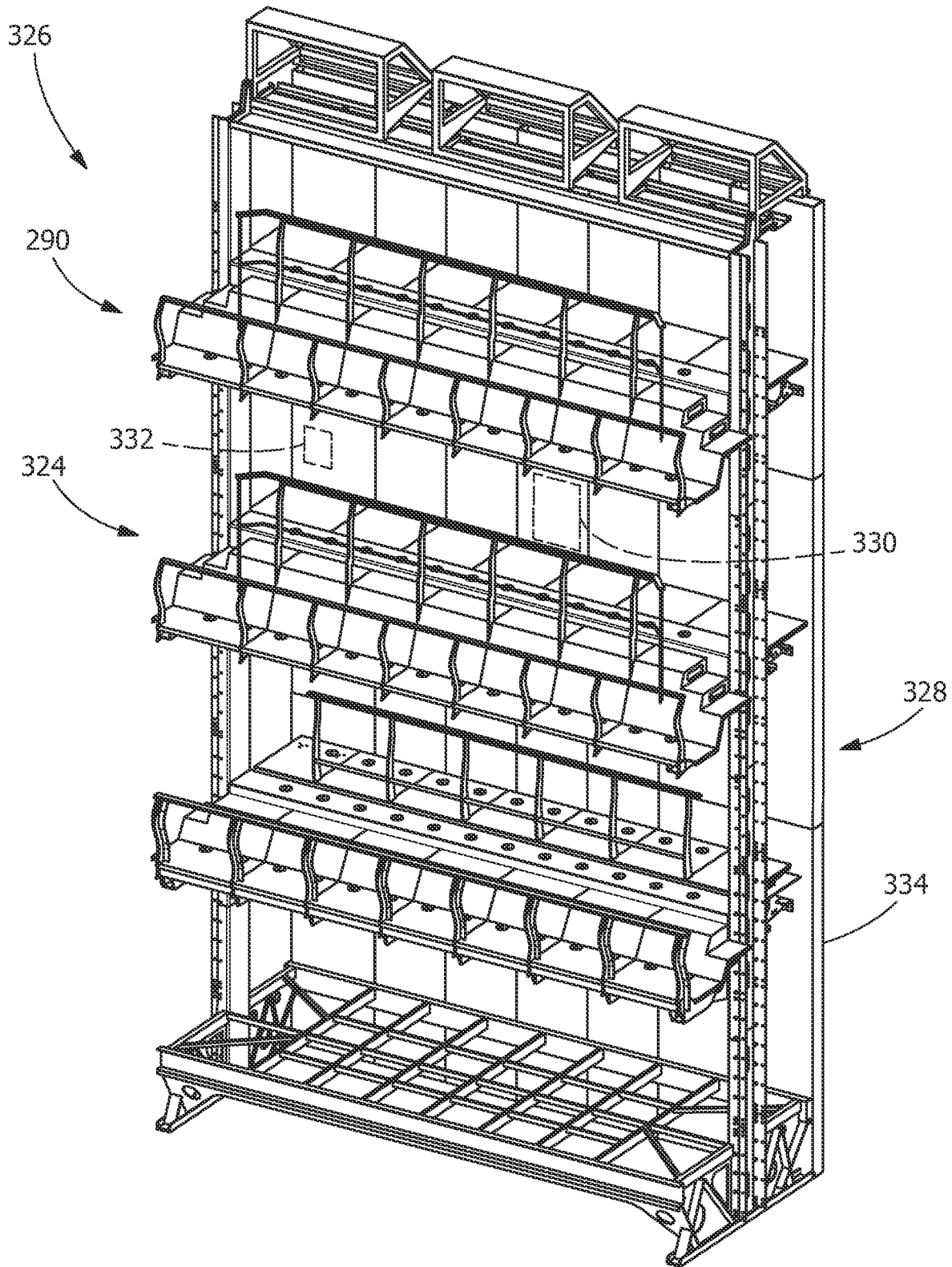

FIG. 34

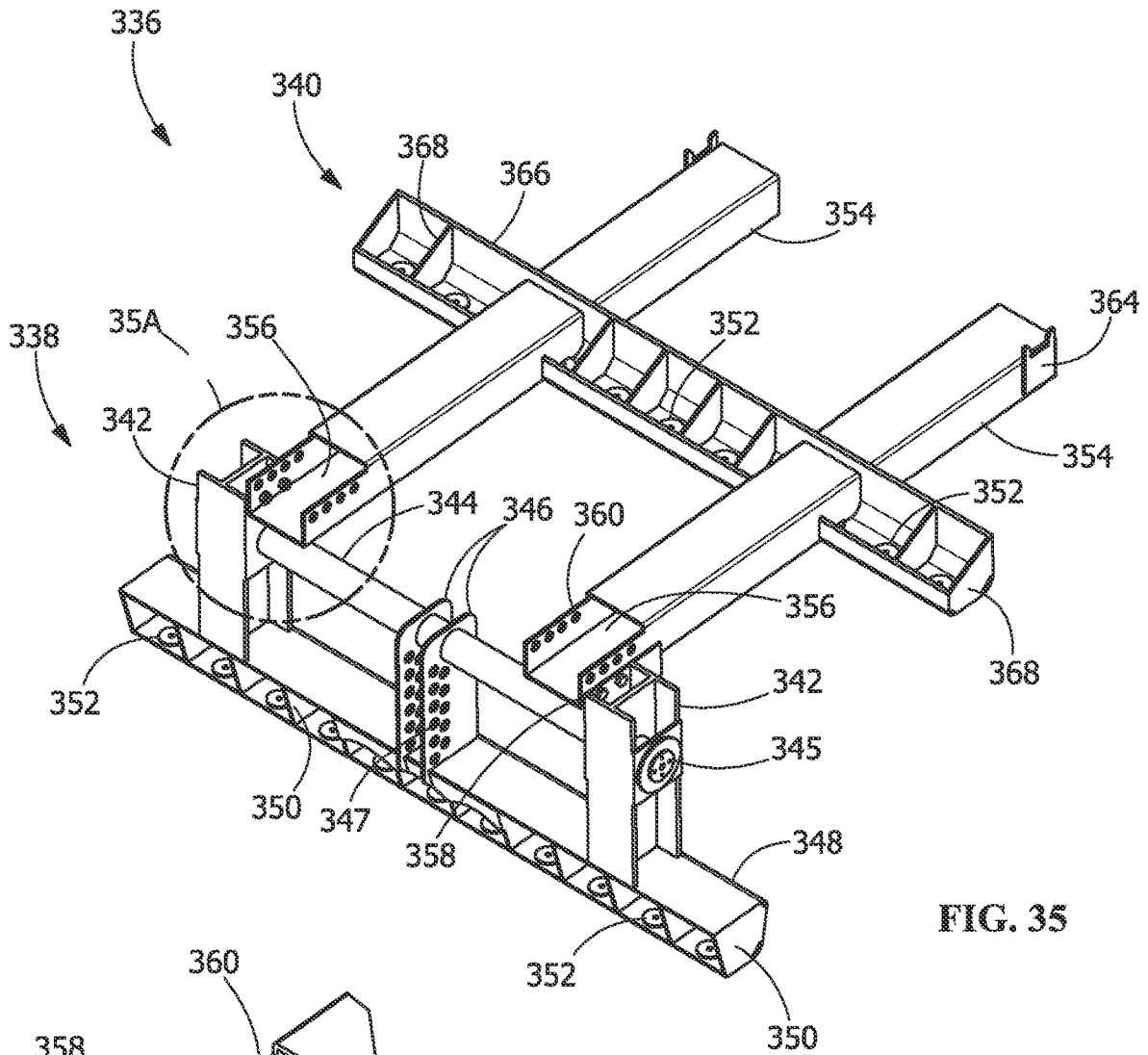

FIG. 35

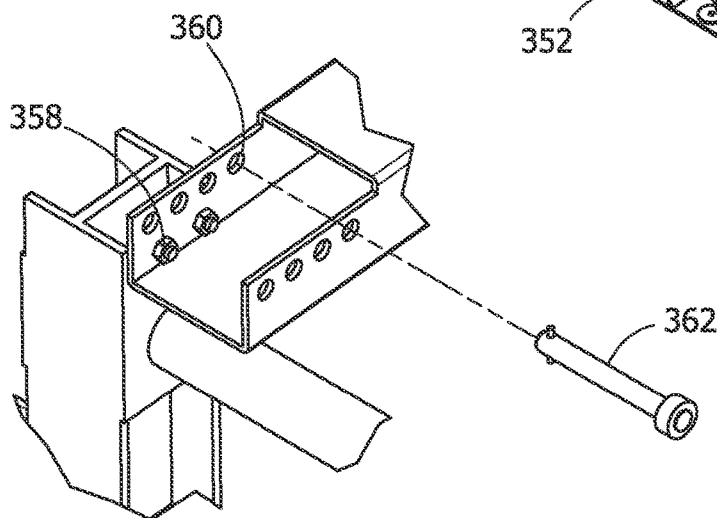

FIG. 35A

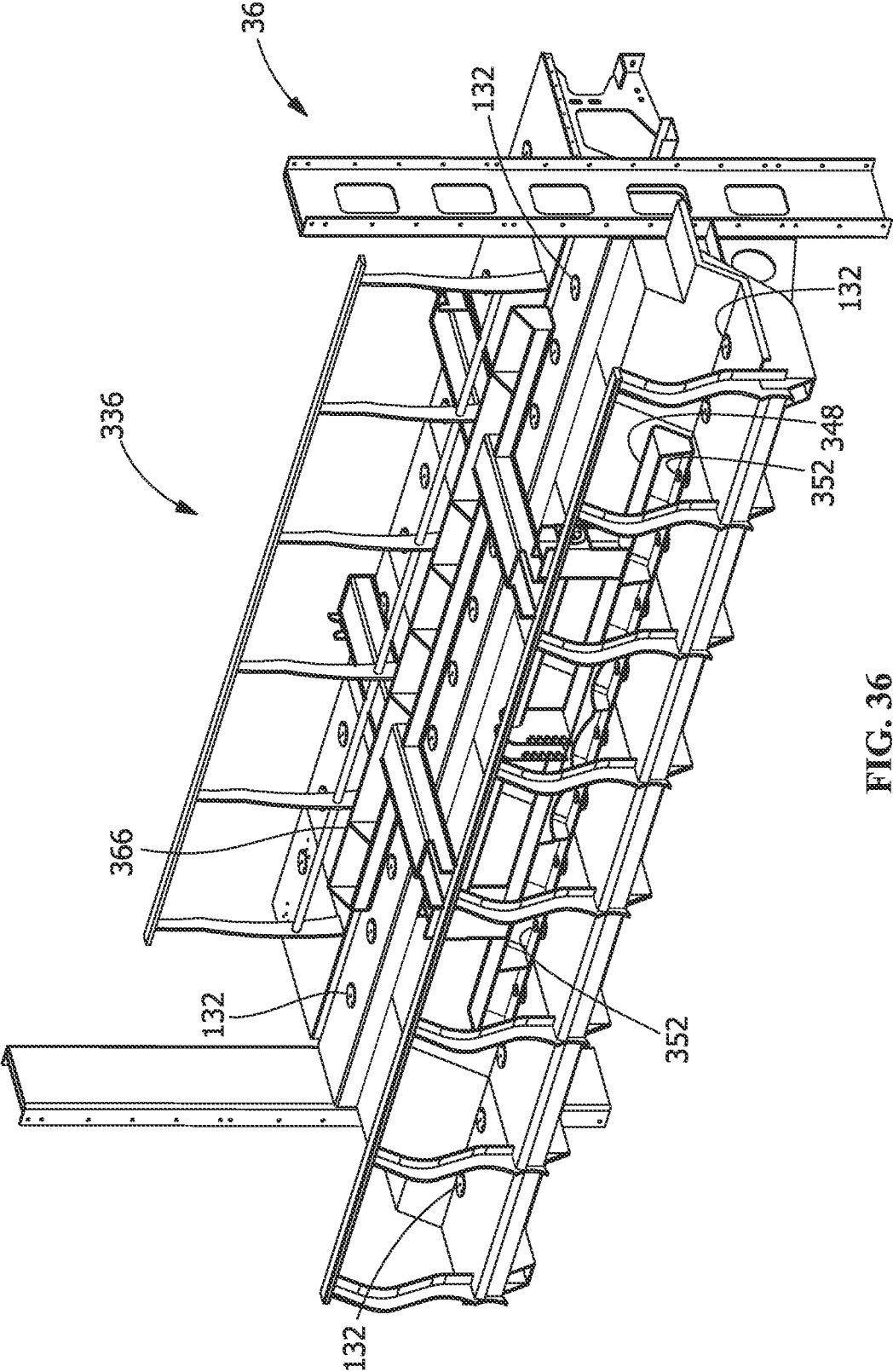

FIG. 36

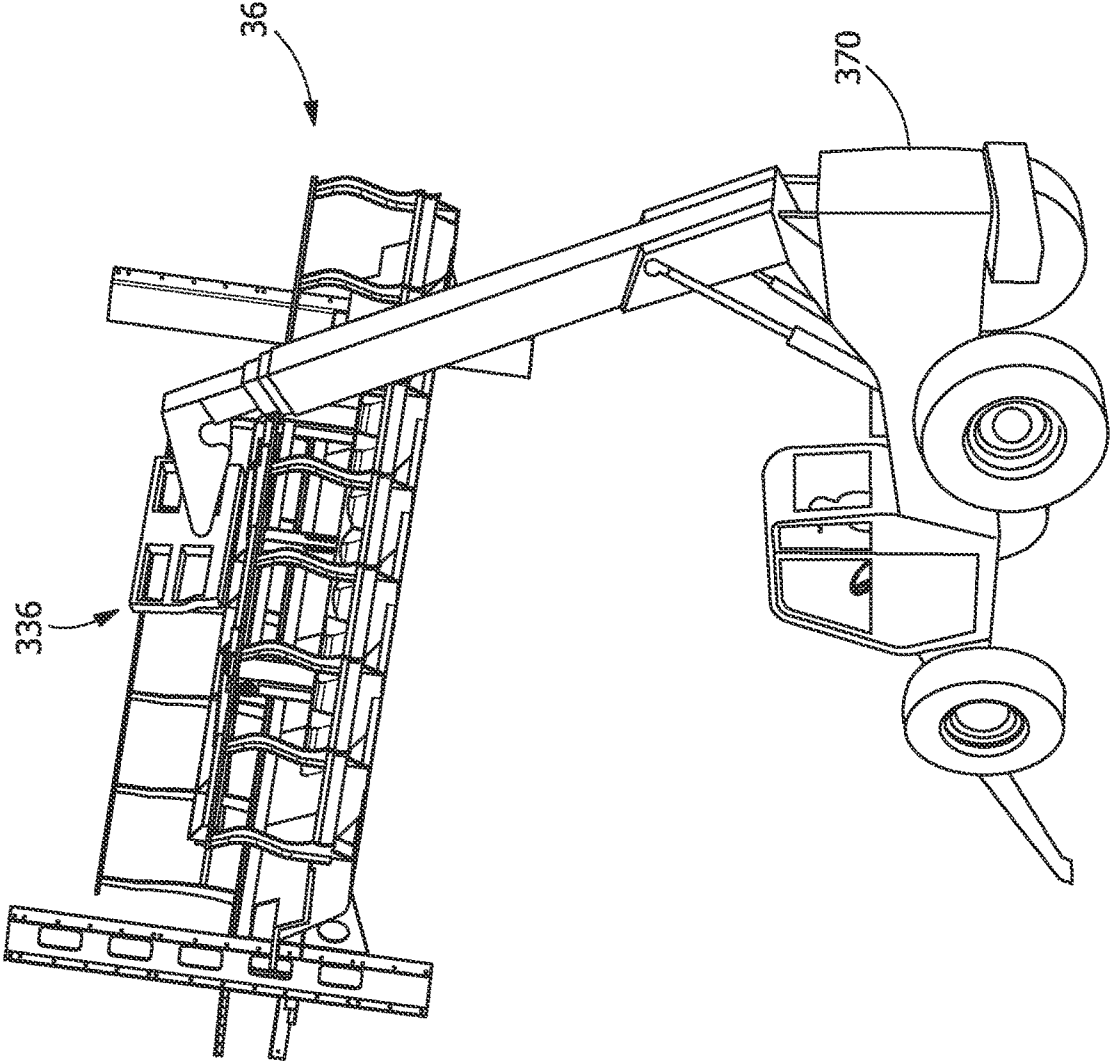

FIG. 37

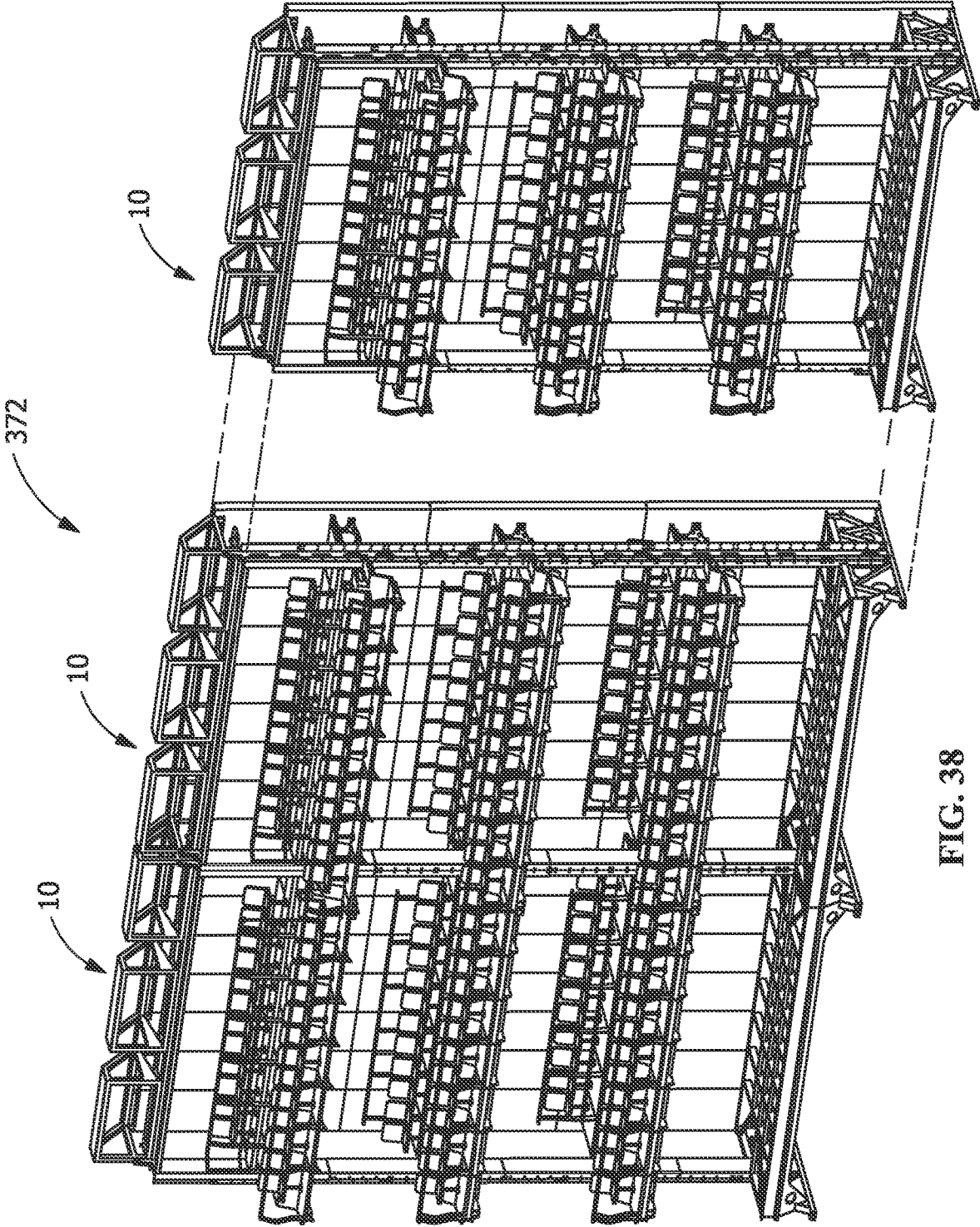

FIG. 38

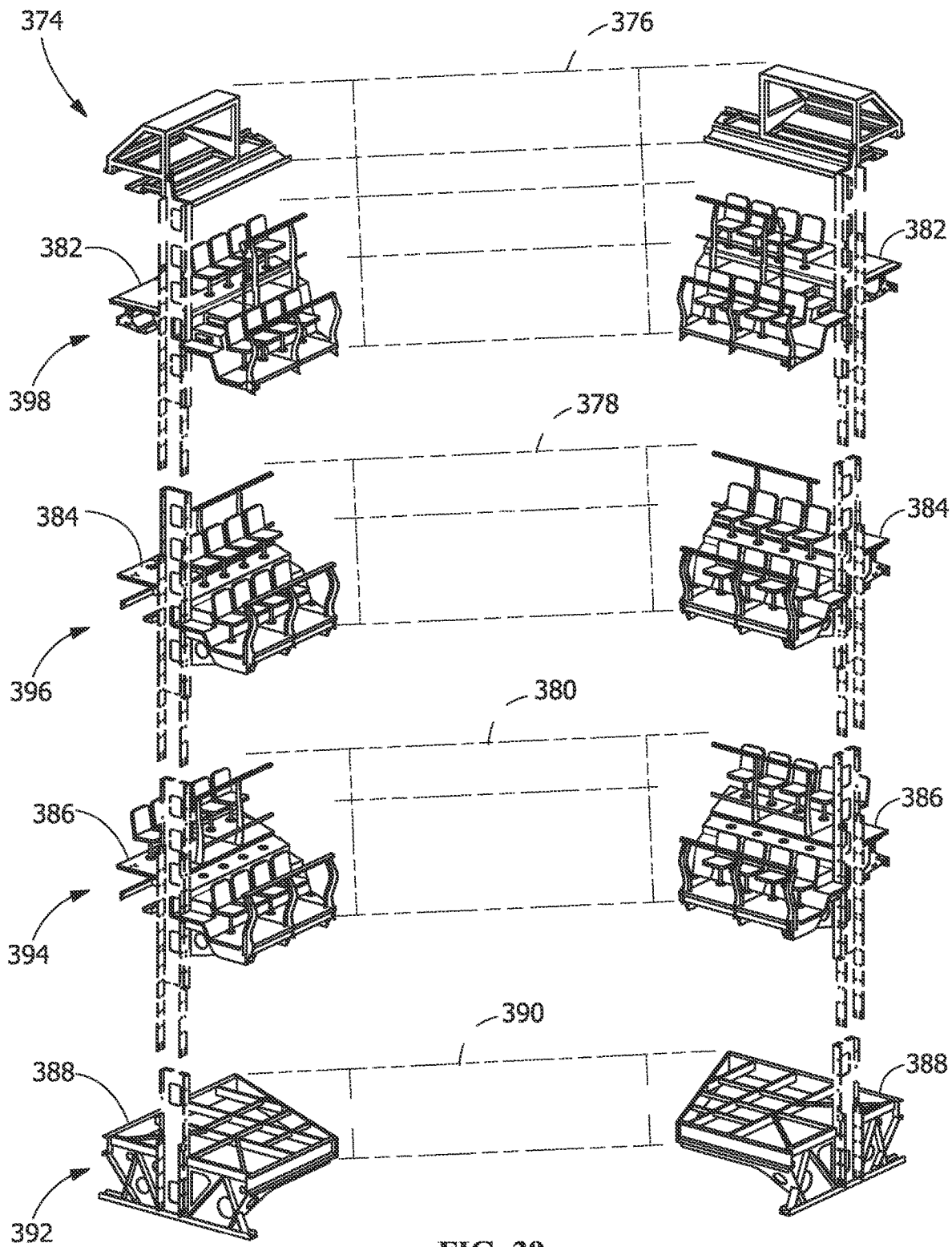

FIG. 39

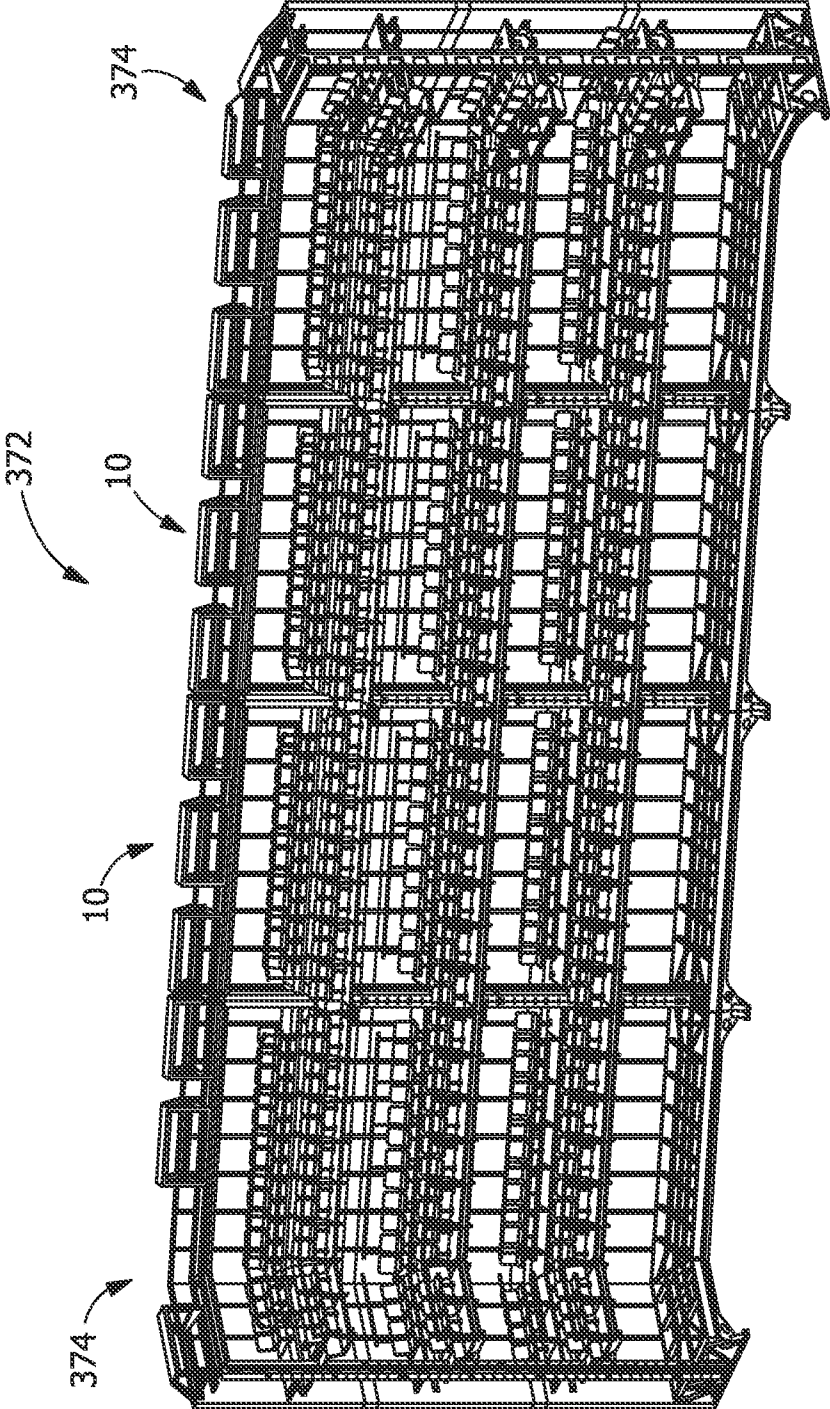

FIG. 40

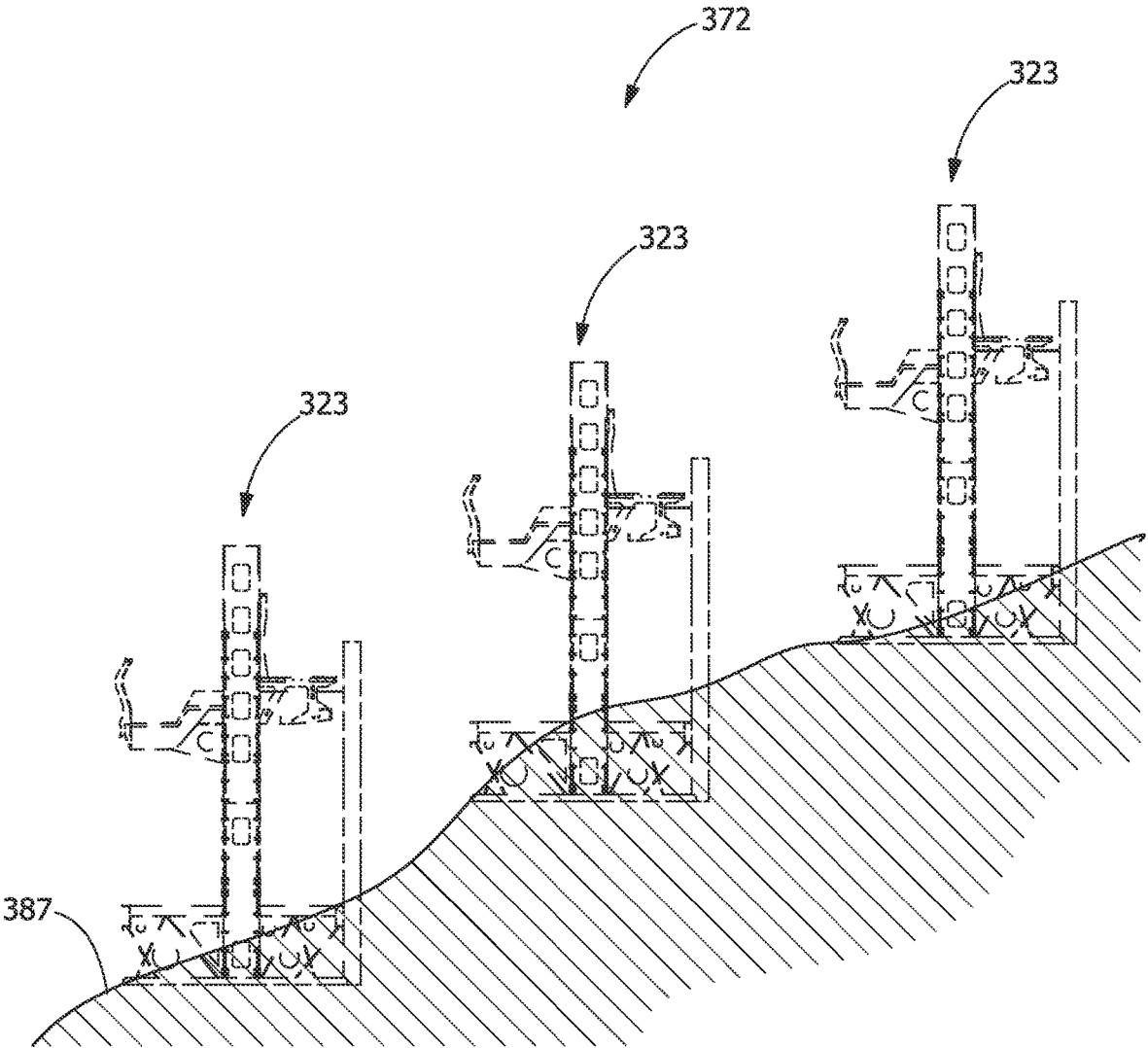
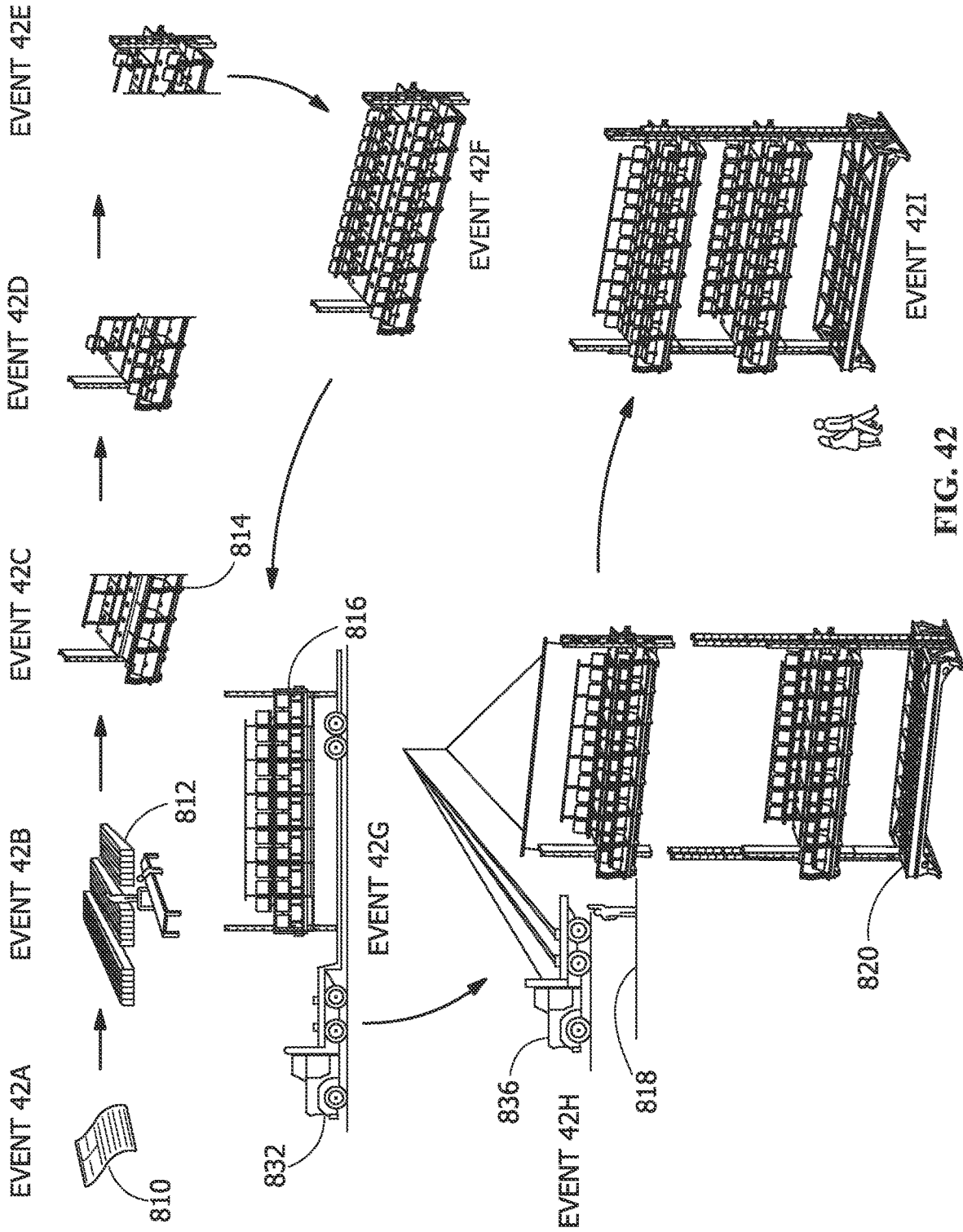

FIG. 41



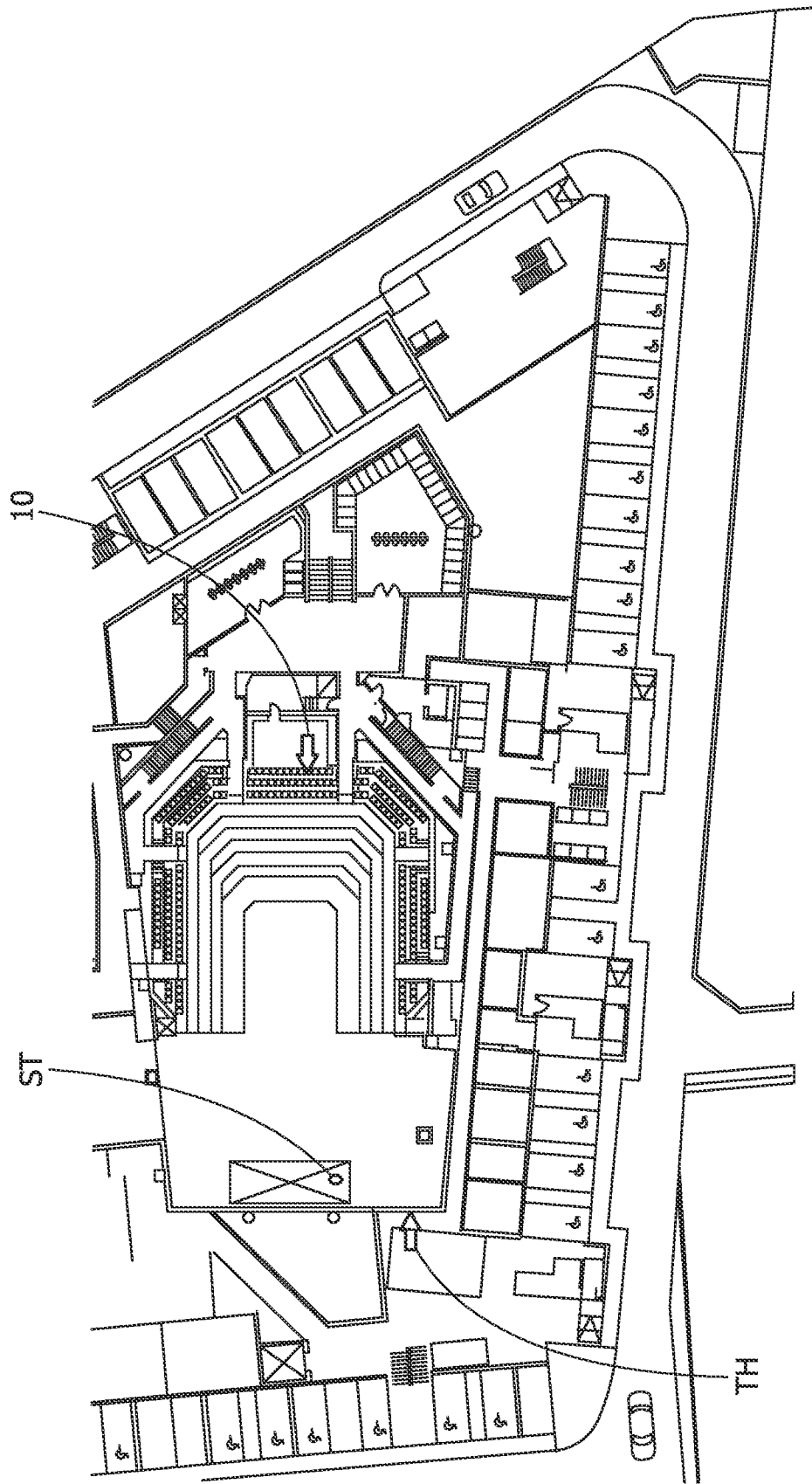

FIG. 43

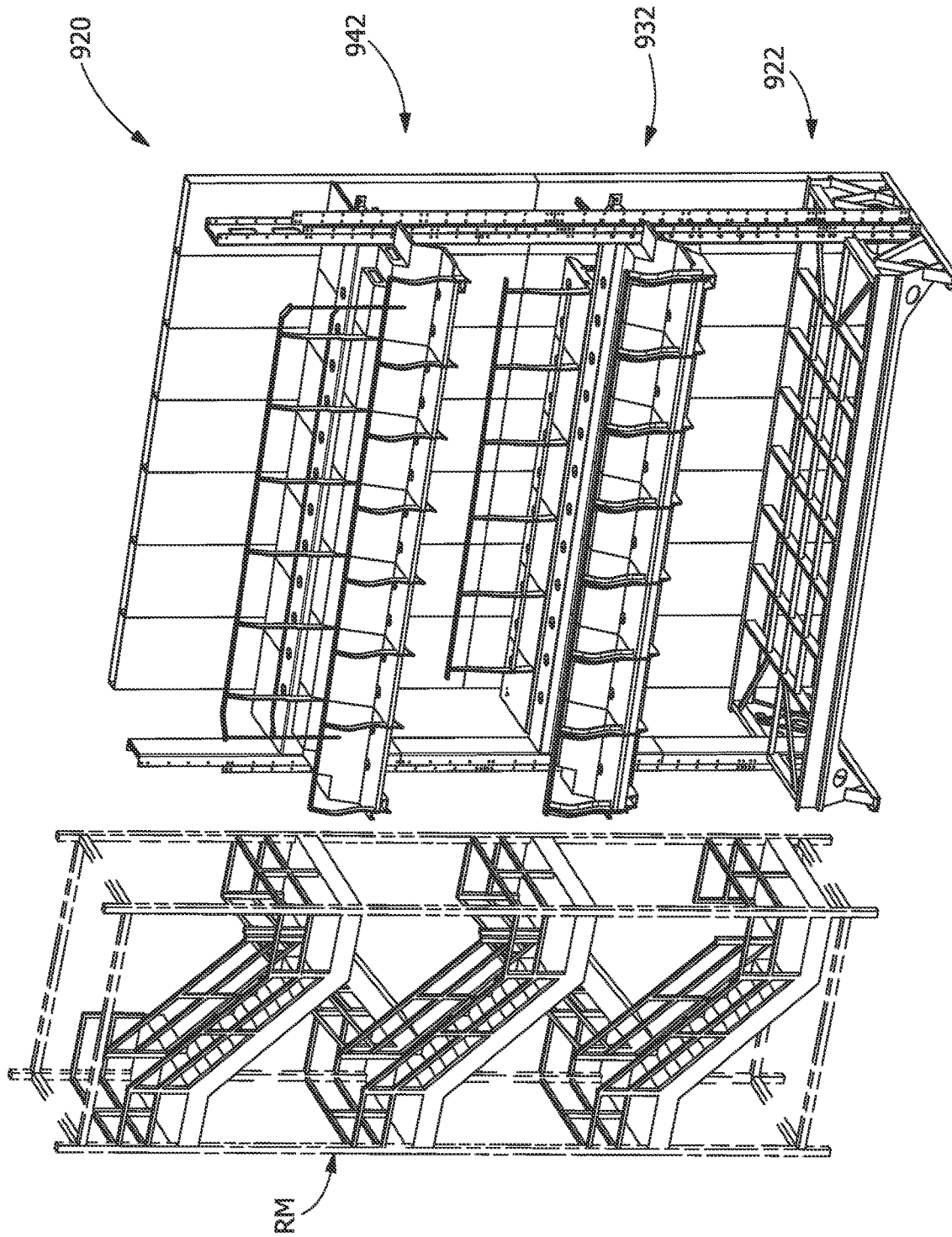

FIG. 44

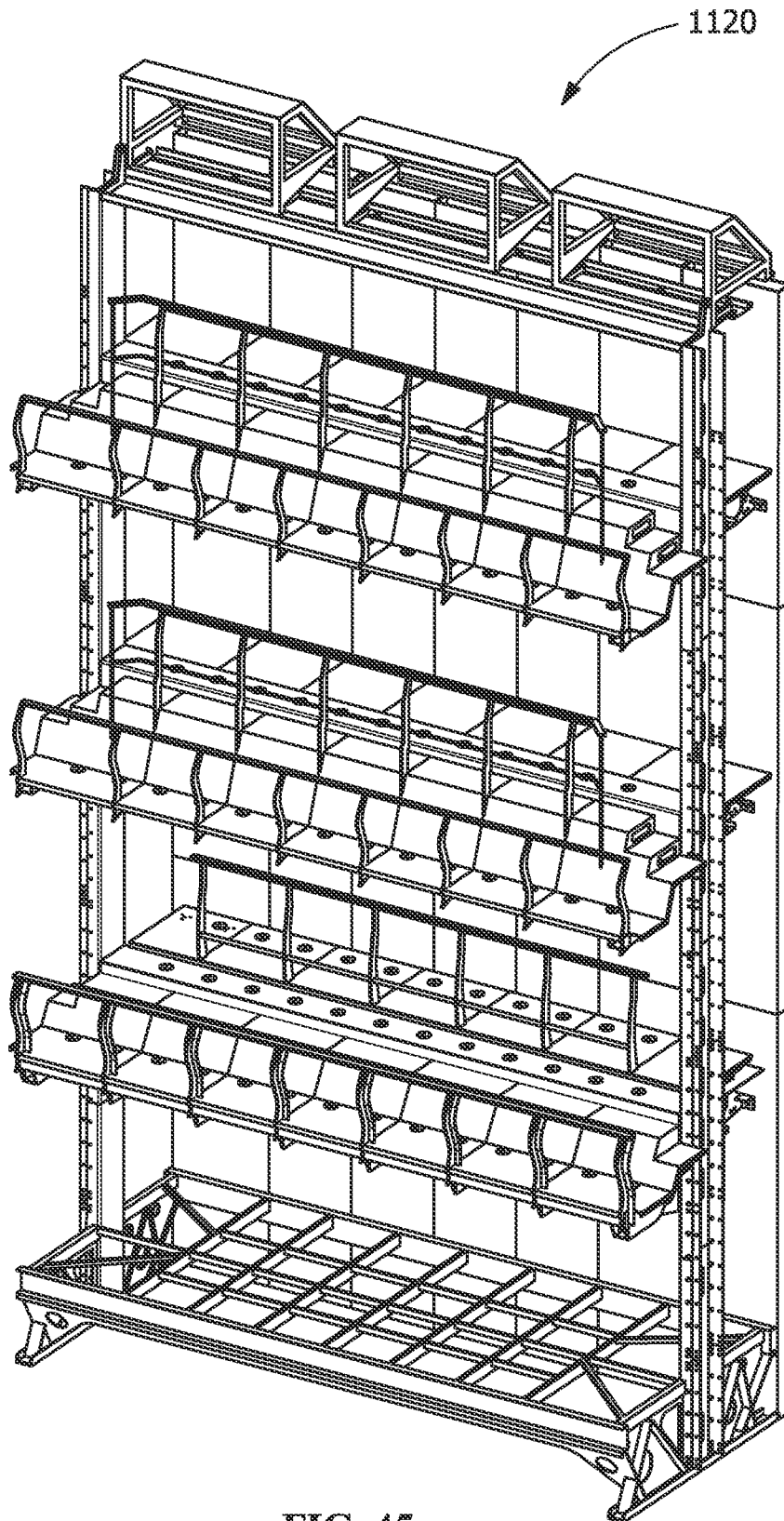

FIG. 45

**THEATER HAVING A MODULAR
AUDITORIUM AND METHOD FOR
ASSEMBLING A THEATER**

CROSS-REFERENCE TO RELATED
APPLICATIONS

The present application is a continuation application, which claims priority and benefit of Non-Provisional patent application Ser. No. 17/212,587, filed Mar. 25, 2021, currently; Non-Provisional patent application Ser. No. 16/685,212, filed Nov. 15, 2019, now U.S. Pat. No. 11,066,840; Non-Provisional patent application Ser. No. 15/723,563, filed Oct. 3, 2017, now U.S. Pat. No. 10,513,861; and U.S. Provisional Patent Application No. 62/410,088, filed Oct. 19, 2016, each of which are incorporated by reference in their entirety.

FIELD OF THE INVENTION

The present invention is directed to auditoriums, and in particular, to prefabricated auditoriums and methods for manufacturing and transporting prefabricated auditoriums.

BACKGROUND OF THE INVENTION

It is sometimes desirable to reconfigure building structures. For example, it may be desirable to reconfigure a building structure so as to place the structure in a condition in which it is more suitable for operation as a public performance space capable of comfortably accommodating patrons who attend live events, recorded media presentations, or combinations thereof. Sometimes the reconfiguration of the structure may entail relatively extensive, and perhaps relatively costly, modifications to the structure to ensure that the re-configured structure meets an aesthetics standard and meets audience satisfaction standards such as, for example, satisfactory sight lines for each patron to view a performance and suitable fixtures providing adequate comfort at the viewing locations (i.e., seats or other customary audience gallery accommodations).

It would be desirable to provide apparatus and previously configured modules that facilitate the reconfiguration of building structures for use as public performance spaces and to provide methods of manufacturing such previously configured modules and methods for transporting and erecting such previously configured modules at the locations of the public performance spaces. Additionally, it would be desirable to provide apparatus and previously configured modules that facilitate the original construction of building structures operable as public performance spaces and to provide methods of manufacturing such previously configured modules and methods for transporting and erecting such previously configured modules at the locations of the public performance spaces.

SUMMARY OF THE INVENTION

An embodiment according to the present disclosure is directed to a method for assembling a modular auditorium. The method includes providing a plurality of nominal inventory portions. Each nominal inventory portions includes a prefabricated base portion, and a prefabricated tier section for assembly to the base portion. The prefabricated base portion is positioned on a ground surface of a public performance space. The prefabricated tier section is fastened to the prefabricated base portion to form a self supporting

modular auditorium structure that does not require lateral support from a building structure other than the ground surface.

Another embodiment is directed to a modular auditorium. The modular auditorium includes a plurality of nominal inventory portions for placement on a ground surface of a public performance space. Each nominal inventory portion includes a prefabricated base portion and a prefabricated tier section for assembly to the prefabricated base portion. The modular auditorium, when assembled, is self supporting and does not require lateral support from a building structure other than the ground surface.

Another embodiment is directed to a lifting fixture securable to a lifting machine adapted for lifting/manipulating corresponding tier sections for assembly/disassembly of a modular auditorium including a plurality of tubes connected to a first fixture portion and a second fixture portion, the plurality of tubes adapted to be selectively secured to the lifting machine, the first fixture portion and the second fixture portion including a plurality of lifting interfaces adapted to interface with corresponding lifting interfaces of the corresponding tier sections.

Another embodiment is directed to a lifting fixture securable to a lifting machine adapted for lifting/manipulating corresponding tier sections for assembly/disassembly of a modular auditorium including a plurality of tubes parallel to one another and connected to a first fixture portion and a second fixture portion, the plurality of tubes adapted to be selectively secured to the lifting machine, the first fixture portion and the second fixture portion including a plurality of lifting interfaces adapted to interface with corresponding lifting interfaces of the corresponding tier sections. The lifting fixture further includes the second fixture portion including a plurality of beams connected to the plurality of tubes, the plurality of beams and the plurality of tubes defining an L-shape.

Another embodiment is directed to a lifting fixture securable to a forklift machine adapted for lifting/manipulating corresponding tier sections for assembly/disassembly of a modular auditorium including a plurality of tubes parallel to one another and connected to a first fixture portion and a second fixture portion, the plurality of tubes adapted to be selectively secured to the lifting machine, the first fixture portion and the second fixture portion including a plurality of lifting interfaces adapted to interface with corresponding lifting interfaces of the corresponding tier sections. The lifting fixture further includes the second fixture portion including a plurality of beams connected to the plurality of tubes, the plurality of beams and the plurality of tubes defining an L-shape. The lifting fixture further includes each tube of the plurality of tubes adapted to receive a corresponding fork of the forklift machine, each tube of the plurality of tubes including a fork tine retention feature. The lifting fixture further includes each lifting interface of the lifting interfaces of the corresponding tier sections correspond to a chair interface of the corresponding tier section, the second fixture portion being selectively separable from the plurality of tubes. The lifting fixture further includes the first fixture portion including a first cross member having an open end, a plurality of stiffeners positioned in the open end of the first cross member between each lifting interface of the plurality of lifting interfaces. The lifting fixture further includes the second fixture portion including a second cross member having an open end, a plurality of stiffeners positioned in the open end of the second cross member between each lifting interface of the plurality of lifting interfaces.

Other features and advantages of the present invention will be apparent from the following more detailed description of the preferred embodiment, taken in conjunction with the accompanying drawings which illustrate, by way of example, the principles of the invention.

BRIEF DESCRIPTION OF THE DRAWINGS

FIG. 1 is an upper perspective view of an exemplary modular auditorium.

FIG. 2 is an upper perspective view of an exemplary base portion.

FIG. 2A is an upper perspective view of an exemplary base portion.

FIG. 3 is an exploded view of an exemplary base rig.

FIG. 4 is an upper perspective view of the assembled base rig of FIG. 3.

FIG. 5 is an exploded view of an exemplary frame portion.

FIG. 6 is an exploded view of the assembled frame portion of FIG. 5 and associated assembled base rigs of FIG. 4.

FIG. 7 is an upper perspective view of an exemplary tier section.

FIG. 7A is an upper perspective view of an exemplary tier section.

FIG. 8 is a reverse lower perspective view of the tier section of FIG. 7.

FIG. 9 is a lower perspective view of the tier section of FIG. 7.

FIG. 10 is a side elevation view of the tier section of FIG. 7.

FIG. 11 is an exploded view of an exemplary tier section module.

FIG. 11A is an exploded view of an exemplary tier section module.

FIG. 12 is an assembled upper perspective view of the tier section module of FIG. 11.

FIG. 12A is an assembled upper perspective view of the tier section module of FIG. 11A.

FIG. 13 is an exploded view of an exemplary tier section module.

FIG. 13A is a partial, enlarged view taken from region 13A of FIG. 13, of the exemplary tier section module shown in FIG. 13.

FIG. 14 is an assembled upper perspective view of the tier section module of FIG. 13.

FIG. 15 is an exploded view of assembled tier section modules of FIGS. 12, 12A, 14 and an exemplary beam.

FIG. 16 is an upper perspective view of the assembled tier section modules of FIGS. 12, 12A, 14 and the exemplary beam of FIG. 15.

FIG. 17 is an exploded view of an exemplary assembled tier floor, exemplary guardrails, and exemplary vertical beams.

FIG. 18 is an upper perspective view of an exemplary tier section.

FIG. 18A is an upper perspective view of an exemplary tier section.

FIG. 19 is a reverse lower perspective view of the tier section of FIG. 18.

FIG. 20 is a lower perspective view of the tier section of FIG. 18.

FIG. 21 is a side elevation view of the tier section of FIG. 18.

FIG. 22 is an upper perspective view of an exemplary tier section.

FIG. 23 is a lower perspective view of the tier section of FIG. 22.

FIG. 24 is a reverse lower perspective view of the tier section of FIG. 22.

FIG. 25 is a side elevation view of the tier section of FIG. 22.

FIG. 26 is an upper perspective view of an exemplary tier section.

FIG. 26A is an upper perspective view of an exemplary tier section.

FIG. 27 is a front elevation view of the tier section of FIG. 26.

FIG. 28 is an exploded view of an assembled base portion of FIG. 2 and an assembled tier section of FIG. 7.

FIG. 29 is an enlarged view of region 29 taken from FIG. 28.

FIG. 30 is an upper perspective view of an exemplary nominal inventory portion segment resulting from assembly of the base portion and tier section of FIG. 28.

FIG. 30A is an upper perspective view of an exemplary nominal inventory portion segment resulting from assembly of the base portion and tier section of FIG. 28.

FIG. 31 is an exploded view of an assembled nominal inventory portion segment of FIG. 30 and an assembled tier section of FIG. 18.

FIG. 32 is an upper perspective view of an exemplary nominal inventory portion segment resulting from assembly of the nominal inventory portion segment and tier portion of FIG. 31.

FIG. 32A is an upper perspective view of an exemplary nominal inventory portion segment resulting from assembly of the nominal inventory portion segment and tier portion of FIG. 31.

FIG. 33 is an upper perspective view of an assembled tier section of FIG. 26 and an assembled nominal inventory portion segment of FIG. 32.

FIG. 34 is an upper perspective view of an exemplary nominal inventory portion segment resulting from assembly of the tier section and nominal inventory portion segment of FIG. 33.

FIG. 35 is an upper perspective view of an exemplary lifting fixture.

FIG. 35A is an enlarged, partial view taken from region 35A of FIG. 35.

FIG. 36 is an upper perspective view of the lifting fixture of FIG. 35 secured to an exemplary tier section.

FIG. 37 is a lower perspective view of an exemplary forklift machine transporting the tier section and the lifting fixture of FIG. 36.

FIG. 38 is an exemplary modular auditorium.

FIG. 39 is an exemplary nominal inventory portion.

FIG. 40 is an exemplary modular auditorium.

FIG. 41 is an exemplary modular auditorium.

FIG. 42 is a schematic of an exemplary configuration cycle including events 42(A)-42(I), for configuring a performance space of an exemplary audience host combination.

FIG. 43 is a schematic top plan view of an exemplary theater.

FIG. 44 is an exemplary audience host combination.

FIG. 45 is an exemplary modular auditorium.

DETAILED DESCRIPTION OF THE INVENTION

The present invention provides a modular auditorium and a method for manufacturing a modular auditorium in its entirety in the form of a previously configured module, a

type of which is herein denominated as a prefabricated module, or a modular auditorium comprised at least in part of a prefabricated module. As used herein, the term “modular auditorium” is intended to refer to a particular configuration of an audience host combination that is specifically configured to be deployable as an element of a theater having a performance space. The following description provided in connection with FIGS. 1-2, 2A, 3-7, 7A, 8-11, 11A, 12, 12A, 13, 13A, 14-18, 18A, 19-26, 26A, 27-30, 30A, 31, 32, 32A, 33-35, 35A, 36-45 is directed to a modular auditorium.

As seen in FIG. 1, which is an upper perspective view of an exemplary modular auditorium, a modular auditorium hereinafter designated as the modular auditorium MOD-AD may be configured to facilitate the reconfiguration of building structures for use as public performance spaces or may be configured to facilitate the original construction of building structures operable as public performance spaces. The modular auditorium MOD-AD is constructed such that only the surface for supporting the weight of the modular auditorium MOD-AD (i.e., a prepared ground surface or a man-made surface supported above a ground surface) is required. In other words, the modular auditorium MOD-AD is self-supporting and does not require lateral support from another building structure. As a result, the modular auditorium MOD-AD can be assembled inside of a building structure, such as an existing enclosed building structure (i.e., having a roof) for protecting the modular auditorium MOD-AD from the weather. The modular auditorium MOD-AD includes one or more arbitrarily designated nominal inventory portions having one or more tier sections supported by a base portion. Each nominal inventory portion includes a tier floor having corresponding floor portions that are cantilevered from a longitudinal beam or torque tube. The floor portions are made up of modules composed of ribs interconnected to panels. The panels include openings configured to permit at least one of the following: to receive illumination sources, to provide ventilation therethrough and to receive a sound generating device. Each nominal inventory portion also includes seats and handrails. A back wall is constructed with passageways for providing electrical wiring, conveying ventilation air, as well as providing egress/ingress for spectators to each tier of the nominal inventory portions. Each nominal inventory portion is configured to be transportable and positioned for assembly with other nominal inventory portions, such as by a forklift machine. As a result, assembly of the modular auditorium MOD-AD is greatly simplified and can be achieved quickly.

For purposes herein, the term “prefabricated” is intended to mean that a nominal inventory portion as disclosed in further detail below is comprised of base portions and tier sections, each of which is structurally complete to a significant extent and, consequently, merely requiring the interconnection of the base portions and tier sections, such as by mechanical fasteners or welding, to essentially complete the structural assembly of the nominal inventory portion at the permanent site. It is to be understood that the installation or interconnection of components for ventilation or illumination purposes, the installation or interconnection of any electrical wiring or related components or ornamental features, and the installation of seating for each tier section can occur subsequent to the interconnection of the base portions and tier sections, and that these type of components are typically not considered as providing additional structural support. For purposes herein, the term “projecting” is intended to mean an orientation of one piece or component to another piece or component and includes both the situa-

tion in which one piece or component projects relative to, and is completely supported by, the other piece or component and the situation in which neither the one piece or component or the other piece or component completely support the other respective piece or component.

FIG. 1 shows the nominal inventory portion 10 having a base portion 12 and three tier sections 36, 210, 290. In one embodiment, the nominal inventory portion can have a different number of tier sections than three. As shown in FIGS. 2-6, base portion 12 includes a frame 14 and a pair of vertical beams 16. As shown, frame 14 includes a frame portion 18 and a frame portion 22 (FIG. 6). As shown in FIGS. 3-4, each vertical beam 16 is secured to a corresponding frame portion 18 such as by welding, mechanical fasteners or other suitable technique. Securing frame portion 18 to vertical beams 16 results in a base rig 20. FIG. 5 shows an exploded view of an unassembled frame portion 422, with FIG. 6 showing an assembled frame portion 22. Frame portion 422 includes opposed longitudinal beams 24 that are secured to a plurality of frame members 26 extending generally perpendicular to longitudinal beams 24. Longitudinal frame members 28 extend generally perpendicular to and are secured to adjacent frame members 26. As shown in FIGS. 5-6, a pair of opposed frame members 30 extend outwardly from the outermost positioned frame members 26. Frame members 32, which extend generally parallel to frame members 26, are secured to corresponding frame members 30. Frame members 30, 32 form opposed end sections 34. FIG. 6 shows an exploded view of assembled frame portion 22 positioned between opposed base sub-assemblies 20. Assembly of frame portion 22 and base sub-assemblies 20 forms frame 14 (FIG. 2).

In one embodiment, as shown in FIG. 2A, base portion 13 essentially includes the combination of base portion 12 (FIG. 2) and a back wall portion 15 of the back wall 11 (FIG. 1). In one embodiment, a back wall portion 39 of the back wall is combined with tier section 37 (FIG. 7A), not base portion 12. In one embodiment, a back wall portion of the back wall is combined with each of base portion 13 and tier section 211.

FIGS. 7-10 show a tier section 36. Tier section 36 includes a longitudinal beam 68 having opposed ends that are secured to vertical beams 50. Tier section 36 further includes a tier floor 38 having a “loge” floor portion 40 forming a forward section and an opposed floor portion 42 forming a backset section. Floor portions 40, 42 are oriented in front-to-back staggered relation to one another and are secured to opposed regions, such as opposed vertical walls of longitudinal beam 68 (rectangular cross-section shown in FIG. 15) such that floor portions 40, 42 are cantilevered from longitudinal beam 68.

For purposes herein, the term “loge” is intended to mean the region or forward extent of a tier section facing toward a performance space. For example, “loge” floor portion 40 of tier section 36 faces toward a performance space, with opposed floor portion 42 facing away from the performance space.

As further shown in FIGS. 7 and 10, floor portion 40 includes horizontal surfaces 41, 45 bridged by an angled surface 43. Horizontal surface 41 corresponds to panels 86 of outer modules 44 (FIG. 11) and to panels 158 of inner modules 46 (FIG. 11A). Horizontal surface 45 corresponds to panels 90 of outer modules 44 (FIG. 11) and to panels 162 of inner modules 46 (FIG. 11A). Angled surface 43 corresponds to panels 88 of outer modules 44 (FIG. 11) and to panels 160 of inner modules 46 (FIG. 11A). As further shown in FIG. 10, surfaces 41, 43, 45 trace a crooked line.

Horizontal surface **41** is positioned vertically above horizontal surface **45**. As a result of this arrangement, it is apparent to one having ordinary skill in the art that the seating density, i.e., the number of seats per unit volume of tier section, **36** is increased, as a row of seats can be mounted on horizontal surface **45**, and an additional row of seats can be mounted on the upper surface of longitudinal beam **68** that is adjacent to horizontal surface **41**. By placing a row of seats on longitudinal beam **68**, versus placing a row of seats extending from the horizontal surface of floor portion **42**, floor portion **42** can accommodate increased accessibility, such as by wheelchairs.

As further shown in FIG. 7, floor portion **40** includes a guardrail **54** including rail supports **56** and a rail **58**. Floor portion **42** includes a guardrail **60** including rail supports **62**, support members **64** extending between adjacent rail supports **62** and a rail **66**.

FIG. 11 shows an exploded view of an unassembled outer module **444**, and FIG. 12 shows an assembled outer module **44**.

As further shown in FIG. 11, module **444** includes a rib **70** having an optional light guide hole **77** and edges **74**, **75**, **76**, **78**, **79**. A rib **72** has an optional light guide hole **85** and edges **80**, **81**, **82**, **84**. Panels **86**, **94**, and most of each of panels **88**, **92**, **94** are positioned between and secured to each of ribs **70**, **72**. For example, as for panel **86**, end **100** of panel **86** is secured to edge **74** of rib **70**, edge **104** of panel **86** is secured to edge **106** of panel **88**, and end **102** of panel **86** is secured to edge **122** of stair tread portion **92**. As for panel **88**, edge **108** is secured to edge **120** of stair tread portion **92**, edge **110** of panel **88** is secured to edge **118** of stair tread portion **92**. A portion of panel **88** terminating at edge **112** of panel **88** extends over and is supported by and secured to each of edge **82** of rib **72** and edge **148** of cap **142**. Edge **113** of panel **88** is secured to edge **130** of panel **90**, and edge **115** of panel **88** is secured to edge **76** of rib **70**. As for panel **90**, which includes one or more chair/lifting interfaces **132**, end **126** of panel **90** is secured to edge **78** of rib **70**. A portion of panel **90** terminating at end **128** extends over and is supported by and secured to each of edge **84** of rib **72** and edge **150** of cap **142**. A curved panel **94** has opposed ends **96**, **98**, with end **96** of panel **94**, **160**, secured to edge **75** of rib **70**, and end **98** of panel **94** secured to the facing vertical surface of rib **72**. Stair tread portion **92** includes a riser **116** having an optional opening **124** (for receiving an illumination source (not shown) for providing illumination to stair tread portion **92**). Stair tread portion **92** further includes a tread **114** having an edge **117** secured to an edge **80** of rib **72**.

As further shown in FIG. 11, outer module **444** includes a box structure portion **52**. Box structure portion **52** is formed by tread **114**, panels **88**, **90**, rib **72**, a curved panel **134**, and cap **142**. Curved panel **134** includes opposed ends **136**, **138** and an opening **140** configured to permit at least one of the following: to receive illumination sources (not shown), to provide ventilation therethrough and to receive a sound generating device (not shown). End **136** of panel **134** is secured to rib **72** along a region **436** identified in dashed lines on rib **72**. End **138** of panel **134** is secured to a curved edge **144** of cap **142**, and end **136** of panel **134** is secured to region **436** (shown in dashed lines) of rib **72**. Panel defines the lower portion of box structure portion **52** (FIG. 12). The upper portion of box structure portion **52** is defined by tread **114** and panels **88**, **90**. That is, a portion of tread **114** terminating at edge **117** extends over and is secured to edge **80** of rib **72** and edge **146** of cap **142**. A portion of panel **88** terminating at edge **112** extends over and is secured to edge **82** of rib **72** and edge **148** of cap **142**. A portion of panel **90**

terminating at end **128** extends over and is secured to edge **84** of rib **72** and edge **150** of cap **142**. A flange **154** is secured to edge **117** of tread **114**, edge **112** of panel **88** and end **128** of panel **90**, with stiffeners **152** positioned between and secured to each of flange **154** and cap **142**.

FIG. 11A shows an exploded view of an unassembled inner module **446**, and FIG. 12A shows an assembled inner module **46**.

As further shown in FIG. 11A, module **446** includes a pair of ribs **70** each having an optional light guide hole **77** and edges **74**, **75**, **76**, **78**, **79**. Panels **158**, **160**, **162**, and stiffener **182** most of each of panels **88**, **92**, **94** are positioned between and secured to each of ribs **70**. For example, as for panel **158**, end **161** of panel **158** is secured to edge **74** of rib **70**, edge **164** of panel **158** is secured to edge **170** of panel **160**, and end **163** of panel **158** is secured to edge **74** of rib **70**. As for panel **160**, end **166** is secured to edge **76** of rib **70**, edge **172** panel **160** is secured to edge **178** of panel **162**. End **168** of panel **160** secured to edge **76** of rib **70**. As for panel **162**, end **174** is secured to edge **78** of rib **70** and end **176** of panel **162** is secured to edge **78** of rib **70**. As for stiffener **182** opposed ends **184**, **186** are secured to corresponding vertical surfaces of ribs **70**.

FIG. 13 shows an exploded view of an unassembled module **448**, and FIG. 14 shows an assembled outer module **48**.

As further shown in FIG. 13, module **448** includes opposed ribs **188** that support a panel **192**. Stiffeners **190** extend between and are secured to ribs **188** and panel **192**. Each of ribs **188** includes a recess **189** and outwardly extending legs **191**, **193**. As further shown in FIG. 13, leg **193** terminates at edges **194**, **196**, **198**. The outermost positioned ribs **188**, as shown in FIG. 13A include a variation of leg **193**, in which edge **194** is replaced by an L-shaped bracket **200** having a slotted opening **202**.

It is to be understood that adjacent modules **44**, **46**, **48** can share a common rib. In one embodiment, one or more of adjacent modules **44**, **46**, **48** can have their own separate ribs. By virtue of the panels and structural members secured to the ribs, and possibly the longitudinal beam **68**, the modules have additional structural strength and rigidity, and can act as additional torque tubes, or torque transmitting members.

FIG. 15 is an exploded view of floor portions **40**, **42** including assembled tier section modules **44**, **46**, **48** secured to opposed regions, such as opposed vertical sidewalls of longitudinal beam **68**. A U-shaped beam **206** is secured to edges **198** of modules **48**, providing a raceway in the form of a trough for electrical wiring and other uses. A cap **204** is secured to edges **194** of ribs **188**, except for the outermost positioned ribs **188**, to which a corresponding portion of back wall **39** (FIG. 7A) is secured via a slotted opening **202** (FIG. 13A) of L-shaped bracket **200** (FIG. 13A) by fasteners (not shown). Additionally, a tubular beam **208** is inserted through openings formed by recesses **189** (FIG. 13) of ribs **188** and secured to recesses **189** and panels **192** (FIG. 13) of modules **48**.

FIG. 17 is an exploded view of an assembled tier floor **38**, guardrails **54**, **60**, and vertical beams **50**. In one embodiment, at least a portion of rail support **56** extends from ribs **70**, **72**. That is, the rail supports can extend from corresponding ends of the ribs. Stated another way, the rail supports can be of one-piece or unitary construction with the ribs. This arrangement can be equally applicable to other tier floors of other tier sections.

FIGS. 18-21 show a tier section **210**. Tier section **210** includes a longitudinal beam **224** having opposed ends that

are secured to vertical beams **230**. Tier section **210** further includes a tier floor **212** having a “loge” floor portion **214** and an opposed floor portion **216**. Floor portions **214**, **216** are secured to opposed regions, such as opposed vertical walls of longitudinal beam **224** (rectangular cross-section shown in FIG. **15** for longitudinal beam **68**) such that floor portions **214**, **216** are cantilevered from longitudinal beam **224**. As further shown in FIG. **18**, floor portion **214** includes a guardrail **226**. Floor portion **216** includes a guardrail **228**. Outer module **218**, inner module **220**, and module **222** are similar to respective modules **44**, **46**, **48**, which discussion is not repeated herein. Box structure portion **232** is similar to box structure portion **52**, which discussion is not repeated herein.

As further shown in FIGS. **18-21**, the lower surfaces of modules **218**, **220** are defined by panels **242**, **244**, **246** having respective openings **236**, **238**, **240**. Openings **248** (FIG. **18**) are also associated with the stair portion (not numbered) of module **218**. Opening **234** is associated with box structure portion **232**. Openings **234**, **236**, **238**, **240**, **248** are configured to permit at least one of the following: to receive illumination sources, to provide ventilation there-through and to receive a sound generating device.

In one embodiment, as shown in FIG. **18A**, tier section **211** essentially includes the combination of tier section **210** (FIG. **18**) and a back wall portion **213** of the back wall **11** (FIG. **1**).

FIGS. **22-25** show a tier section **250**. Tier section **250** includes a longitudinal beam **264** having opposed ends that are secured to vertical beams **270**. Tier section **250** further includes a tier floor **252** having a “loge” floor portion **254** and an opposed floor portion **256**. Floor portions **254**, **256** are secured to opposed regions, such as opposed vertical walls of longitudinal beam **264** (rectangular cross-section shown in FIG. **15** for longitudinal beam **68**) such that floor portions **254**, **256** are cantilevered from longitudinal beam **264**. As further shown in FIG. **18**, floor portion **254** includes a guardrail **266**. Floor portion **256** includes a guardrail **268**. Outer module **258**, inner module **260**, and module **262** are similar to respective modules **44**, **46**, **48**, which discussion is not repeated herein. Box structure portion **272** is similar to box structure portion **52**, which discussion is not repeated herein.

As further shown in FIGS. **22-25**, the lower surfaces of modules **258**, **260** are defined by panels **282**, **284**, **286** having respective openings **276**, **278**, **280**. Openings **288** (FIG. **22**) are also associated with the stair portion (not numbered) of module **258**. Opening **274** is associated with box structure portion **272**. Openings **274**, **276**, **278**, **280**, **288** are configured to permit at least one of the following: to receive illumination sources, to provide ventilation there-through and to receive a sound generating device.

FIGS. **26-27** show a capped tier section **290**, which is tier floor **252** that has been assembled and secured to caps **292**. In one embodiment, as shown in FIG. **26A**, tier section **291** essentially includes the combination of tier section **290** (FIG. **26**) and a back wall portion **293** of the back wall **11** (FIG. **1**).

FIG. **28** shows an exploded view of an assembled base portion **12** (FIG. **2**) and an assembled tier section **36** (FIG. **7**). FIG. **29** shows an enlarged, partial view of region **29** taken from FIG. **28**. As further shown in FIGS. **28-29**, vertical beam **16** of base portion **12** includes a C-shaped structure or channel **294** having flanges **298** extending perpendicularly from opposed ends of web **296**. C-shaped channel **294** has an end **300** and includes a stiffener **299** extending between and secured to opposed flanges **298**. As

further shown in FIGS. **28-29**, a lower portion of C-shaped channel **294** includes a flange extension **302** secured to and extending outwardly from each of flanges **298**. Flange extension **302** has an end **304** that is different from end **300** of C-shaped channel **294**.

Similarly, as shown in FIG. **28**, vertical beam **50** of tier section **36** includes a C-shaped structure or channel **306** having flanges **310** extending perpendicularly from opposed ends of web **308**. C-shaped channel **306** has an end **318** and includes a reinforcing plate **312** extending between and secured to opposed flanges **310**. As further shown in FIGS. **28-29**, a lower portion of C-shaped channel **306** includes a flange extension **314** secured to and extending outwardly from each of flanges **310**. Flange extension **314** has an end **316** that is different from end **318** of C-shaped channel **306**.

In order to assemble and secure vertical beam **50** to vertical beam **16** after aligning the beams as shown in FIG. **28**, vertical beam **50** is lowered into contact with vertical beam **16**. That is, ends **316** of flange extensions **314** are brought into contact with corresponding ends **304** of flange extensions **302**. Simultaneously, ends **318** of C-shaped channel **306** are brought into contact with corresponding ends **300** of C-shaped channel **306**. Once the corresponding flange extensions and C-shaped channels are brought into contact, openings (not numbered) formed in the flange extensions are aligned, and fasteners **320** are installed. By virtue of this arrangement, the vertical beams of base portion **12** and tier section **36** can be secured to each other without requiring welding, saving significant assembly time. FIG. **30** is an upper perspective view of a nominal inventory portion segment **322**, resulting from assembly of base portion **12** and tier section **36**. In one embodiment, as shown in FIG. **30A**, nominal inventory portion segment **323** essentially includes the combination of nominal inventory portion segment **322** (FIG. **30**) and a back wall portion **327** of back wall **11** (FIG. **1**).

FIG. **31** shows an exploded view of assembled nominal inventory portion segment **322** (FIG. **30**) and an assembled tier section **210** (FIG. **18**). FIG. **32** shows an upper perspective view of nominal inventory portion segment **324** resulting from assembly of nominal inventory portion segment **322** and tier section **210**. In one embodiment, as shown in FIG. **32A**, nominal inventory portion segment **325** essentially includes the combination of nominal inventory portion segment **324** (FIG. **32**) and a back wall portion **329** of the back wall **11** (FIG. **1**).

FIG. **33** shows an upper perspective view of an assembled capped tier section **290** (FIG. **26**) and an assembled nominal inventory portion segment **324** (FIG. **32**). FIG. **34** shows an upper perspective view of nominal inventory portion segment **326** resulting from assembly of tier section **290** and nominal inventory portion segment **324** (FIG. **33**). In an alternate embodiment, nominal inventory portion segment **326** further includes back wall **328**, including back wall portion **334**. Openings can be formed in back wall **328** as needed, such as opening **330** to provide ingress/egress to the tier sections by patrons and opening **332** to provide ventilation or openings provided for other reasons.

FIG. **35** shows an L-shaped lifting fixture **336** having fixture portions **338**, **340**. Fixture portion **338** includes a pair of beams **342** extending perpendicularly from opposed ends of a tube **344**. Beams **342** each have a handling interface **345** that is aligned with tube **344**. Tube **344** includes a pair of reinforcing members **346** secured near the center of tube **344**, which reinforcing members **346** including handling features **347** to permit handling of lifting fixture **336**. One end of beams **342** and reinforcing members **346** are secured

to a cross member **348** which includes stiffeners **350**. Cross member **348** includes an open end for permitting access to a plurality of lifting interfaces **352** to permit lifting of a tier section. The ends of beams **342** adjacent to tube **344** includes openings to receive fasteners **358** for securing fixture portion **338** with one end of tubes **354** of fixture portion **340**. Selectably removable fasteners **358** permit separation of fixture portion **338** from fixture portion **340**, permitting installation of the lifting fixture with a tier section. The end of tubes **354** secured to fixture portion **338** include a recess **356** to more easily receive forks of a fork lifting or forklift machine **370** (FIG. 37). Retention features **360** formed in close proximity to recess **356** are configured to receive a retention member **362** (FIG. 35A) for retaining the forks of the fork lifting machine in tubes **354**. Adjacent the opposite ends of tubes **354** are alignment/orientation features **364** for aiding with alignment and orientation of fixture portion **340**. Fixture portion **340** further includes a cross member **366** that is secured to tubes **354**. Cross member **366** includes a plurality of stiffeners **368** and has an open end for permitting access to a plurality of lifting interfaces **352** to permit lifting of a tier section.

FIG. 36 shows lifting fixture **336** in an installed position with each of cross members **348**, **366** positioned such that lifting interfaces **352** of the lifting fixture are aligned with corresponding chair/lifting interfaces **132** of a tier section, such as tier section **36**. FIG. 37 shows a forklift machine **370** lifting/manipulating tier section **36** by virtue of the fork lifting tines of the fork lifting machine engaged with lifting fixture **336**.

FIG. 38 shows a modular auditorium MOD-AD **372** comprised of a plurality of nominal inventory portions **10**. In one embodiment, a single nominal inventory portion **10** can define the modular auditorium MOD-AD.

FIG. 39 shows an alternate configuration of a nominal inventory portion, such as corner nominal inventory portion **374**. As shown in FIG. 39, corner nominal inventory portion **374** includes a base portion **392** and tier sections **394**, **396**, **398** assembled together. Base portion **392** includes a pair of wedge-shaped base portions **388** secured to opposed ends of a frame portion **390**. Tier section **394** includes a pair of wedge-shaped modular sections **386** secured to opposed ends of a modular section **380**, such as a segment of tier section **36** (FIG. 1). Tier section **396** includes a pair of wedge-shaped modular sections **384** secured to opposed ends of a modular section **378**, such as a segment of tier portion **210** (FIG. 1). Tier section **398** includes a pair of wedge-shaped modular sections **382** secured to opposed ends of a modular section **376**, such as a segment of tier portion **290** (FIG. 1). In this construction, corner nominal inventory portion **374** can define a 90 degree angle between opposed vertical beams (collectively shown in phantom line). In one embodiment, the corner nominal inventory portion can define a degree angle other than 90 degrees between opposed vertical beams. In one embodiment, wedge-shaped modules for the same tier section can be different from one another. With the construction such as shown in FIG. 39, it is possible to form a modular auditorium MOD-AD defining a closed geometry, such as a rectangle surrounding a performance space. In one embodiment, such as shown in FIG. 40 for modular auditorium MOD-AD **372**, each corner nominal inventory portion **374** only includes a single set or combination of wedge-shaped base portions **388** and wedge-shaped modules **382**, **384**, **386** (FIG. 39).

FIG. 41 shows a modular auditorium MOD-AD comprised of a plurality of nominal inventory portion segments **323** positioned at different locations along a sloped surface **387**.

It is to be understood that seat density is increased due to the reduced vertical distance between adjacent tier sections, as a result of the reduced vertical distance between adjacent tier sections, due to the “loge” or multilevel floor portions having a front row of seating that is lower than the second row of seating for each of tier sections **36**, **210**, **290** (see FIG. 1).

In one embodiment, the back wall, such as back wall **11** (FIG. 1) can be of unitary construction and provided separately from the tier sections.

It is to be understood that the modular auditorium MOD-AD of the present invention can include more than three tier sections, if desired.

Reference is now had to FIG. 44, which collectively illustrate an exemplary product manufactured in accordance with the method of the present invention and this product has been designed, manufactured (including via the inclusion of pre-fabricated sub-assemblies), and transported to and disposed in an end disposition at a permanent site, in accordance with the present invention. The exemplary product, when disposed in its end disposition at a permanent site, is shown solely for illustration purposes as providing a multi-tier audience accommodation portion of a theater and the exemplary product is hereinafter referred to as the audience host combination **920**.

The audience host combination **920** includes a sill portion **922** that is configured to support thereon a plurality of tiers and each of these tiers is configured as a patron platform capable of handling multiple persons in transit thereacross [e.g., aisle or other passageway] and/or multiple persons as each is located at a viewing location thereon [e.g., seats, wheelchair parking locations, standing patron locations].

The audience host combination **920** includes a first patron platform **932** and a second patron platform **942** and each of the patron platform **932** and the second patron platform **942** are capable of handling multiple persons in transit thereacross [e.g., aisle or other passageway] and/or multiple persons as each is located at a viewing location thereon [e.g., seats, wheelchair parking locations, standing patron locations]. The first patron platform **932** and the second patron platform **942** are supported in the audience host combination **920** relative to one another such that the sight lines of patrons in viewing locations of the first patron platform **932** are not obstructed by the second patron platform **942**.

Each of the first patron platform **932** and the second patron platform **942** comprises one or more pre-fabricated combinations and each pre-fabricated combination: (a) forms a viewing location thereon [e.g., a location at which a seat will be located, a wheelchair parking location, a standing patron location] and (b) comprises an organic load bearing feature.

Each pre-fabricated combination has been pre-fabricated to the extent that it is a ready-to-be-deployed unit that can be lifted, lowered, or otherwise manipulated as a single integral piece into its final position on the audience host combination **920** and the organic load bearing feature of each pre-fabricated combination can be mated with, and/or connected to, the organic load bearing structure of another pre-fabricated combination and/or mated with, or connected to, a support component, such that the pre-fabricated combination can maintain itself as a self-supporting entity after it has been disposed into its final position on the audience host combination **920**. The audience host combination **920** can be

configured identical to the audience host combination 10 described with respect to FIGS. 1-41.

As seen in FIG. 44 in broken lines, a stair tower module RM may be operatively associated with the audience host combination 920 via, for example, multiple connection locations interconnecting the stair tower module RM to a respective one of the vertical columns of the audience host combination 920. The stair tower module RM may provide an access pathway between the several patron platforms of the audience host combination 920 and, optionally, may provide additional structural support for the audience host combination 920 in its final position at the permanent site. The stair tower module RM includes a plurality of stairs, a plurality of handrails, and a plurality of intermediate landings each positioned between a respective pair of stairs and selected ones of which are operatively associated with the patron platforms of the audience host combination 920 so that patrons can transit to and between the patron platforms via the stair tower module RM.

Reference is now had to FIG. 43 and FIG. 45, which collectively illustrate one variation of the exemplary audience host combination shown in FIG. 44. As seen in FIG. 43, which is a schematic top plan view of a theater having a stage and having a variation of the audience host combination of the present invention, the exemplary audience host combination is configured as a modular auditorium 1120 particularly configured for deployment in a theater TH having a stage or performance presentation area, exemplarily shown as a stage ST. The modular auditorium is configured to accommodate patrons at viewing areas from which the patrons can watch a performance on the stage ST of the theater TH. The modular auditorium 1120 includes the core elements of multiple stories of patron platforms supported on vertical columns which themselves are cross-connected and stabilized by a base platform. Additionally, the modular auditorium 1120 engenders a pre-fabricated nature.

With regard to further details of the patron platforms of the modular auditorium 1120, there is provided a group of four patron platforms, each patron platform being capable of handling multiple persons in transit thereacross [e.g., aisle or other passageway] and/or multiple persons as each is located at a viewing location thereon [e.g., seats, wheelchair parking locations, standing patron locations], and each patron platform having a forward region having multiple viewing locations and a backset region having multiple viewing locations, the forward region and the backset region being in front-to-back staggered relationship to each other and the sight lines of patrons in viewing locations of the backset region are not obstructed by the forward region.

With regard to further details of the vertical columns of the modular auditorium 1120, there is provided a pair of vertical columns.

With regard to further details of the base platform of the modular auditorium 1120, each vertical column has its lower end secured to the base platform and the base platform provides structural stability to support the vertical columns in their vertical orientations. The patron platforms are secured to the pair of vertical columns with each patron platform extending to and between the pair of vertical columns and the patron platforms being serially disposed one above another to consequently provide a gallery for patrons comprised of patron platforms each at a respective first story, second story, etc.

Each of the four patron platforms comprises one or more pre-fabricated combinations with each pre-fabricated combination: (a) forming a viewing location thereon [e.g., a location at which a seat will be located, a wheelchair parking

location, a standing patron location] and comprising an organic load bearing feature. Each pre-fabricated combination has been pre-fabricated to the extent that it is a ready-to-be-deployed unit that can be lifted, lowered, or otherwise manipulated as a single integral piece into its final position and the organic load bearing feature of each pre-fabricated combination can be mated with, and/or connected to, the organic load bearing structure of another pre-fabricated combination and/or mated with, or connected to, one of the vertical columns, such that the pre-fabricated combination can maintain itself as a self-supporting entity after it has been disposed into its final position.

Reference is now had to FIG. 42, which is a schematic overview of an exemplary configuration cycle for configuring a performance space with an audience host combination of the present invention. As seen in FIG. 42, an exemplary configuration cycle for configuring a performance space with a modular auditorium of the present invention includes an exemplary process for manufacturing a unit of the modular auditorium, an exemplary method for transporting the thus-manufactured components of the unit of the modular auditorium to a permanent site, and an exemplary on-site method for disposing the unit of the modular auditorium into its end disposition at the permanent site. The exemplary configuration cycle will be described with respect to a series of events schematically shown in FIG. 42 as EVENTS 42(C)-42(I). The exemplary element of the modular auditorium that is described in connection with the exemplary configuration cycle is a unit of the modular auditorium 10 that has been described with respect to FIGS. 1-44.

The exemplary process for manufacturing a unit of the modular auditorium includes an on-site instantiation phase and an off-site phase during which some or all of the unit of the modular auditorium is assembled together prior to instantiation of the unit of the modular auditorium at its permanent site. The off-site phase may be initiated in response to the receipt of an order placed by a customer for a unit of the modular auditorium, as illustrated as EVENT 42(A) in FIG. 42. Each unit of the modular auditorium manufactured in accordance with the exemplary process for manufacturing a unit of the modular auditorium is comprised of a plurality of elements ultimately disposed and/or interconnected to one another and at least one of these elements is created via the application of pre-fabrication production techniques and is denominated as a ship and drop package comprised of a plurality of components assembled with one another.

A work order 810 is produced and given to off-site assembly workers at a component production area 812, as illustrated in EVENT 42(B). At the component production area 812, off-site assembly workers create a stockage of pre-made component parts by measuring, cutting, and drilling raw material from inventory using various jigs. Once measured, cut, and drilled, the pre-made component parts needed to build a ship and drop package for a particular unit of the audience host combination are delivered to a component in-process assembly area 814 (EVENTS 42(C)-42(E)).

The pre-made components are supplied to the off-site assembly workers at the component in-process assembly area 814, whereupon, as a result of several of the components having already been pre-made in the component production area 812, the off-site assembly workers need not measure, drill or cut each and every component part for use in building the ship and drop package. Instead, assembly only involves the assembly of components into a ship and drop package 816 using jigs that are specially made for each ship and drop package 816.

15

All ship and drop packages are completed via various steps, of which several are exemplarily illustrated in EVENTS 42(D)-42(E). Thus, all ship and drop packages 816 are finished at the factory and are ready to attach to an appropriate foundation or other structure, including other ship and drop packages 816, at the permanent site at which the unit of the modular auditorium is to be instantiated—here shown as a building site 818.

At the building site 818, a base pad 820 is prepared. In connection with the method for transporting the thus-manufactured components of the unit of the audience host combination to a permanent site, the ship and drop package 816 and other ship and drop packages are attached to towed trailers 832 for transport from the factory to the building site 818. Loads are appropriate in mass and/or are dimensioned to comply with applicable road transport, rail transport, or waterway transport requirements.

In connection with the exemplary on-site erection sequence for disposing the thus-manufactured ship and drop packages of the unit of the audience host combination into its end disposition at the permanent site, as trailer loads arrive at the building site 818 (EVENT 42(G)), a crane 836 places the ship and drop packages on the prepared base pad 820, as illustrated in EVENT 42(H). When the structure is completed, as illustrated in EVENT 42(I), then the performance space now incorporating the unit of the modular auditorium can be operated to provide performances or further configuration of the performance space can proceed in parallel or in series with the instantiation of the unit of the modular auditorium at the building site 818.

While the invention has been described with reference to a preferred embodiment, it will be understood by those skilled in the art that various changes may be made and equivalents may be substituted for elements thereof without departing from the scope of the invention. In addition, many modifications may be made to adapt a particular situation or material to the teachings of the invention without departing from the essential scope thereof. Therefore, it is intended that the invention not be limited to the particular embodiment disclosed as the best mode contemplated for carrying out this invention, but that the invention will include all embodiments falling within the scope of the appended claims.

What is claimed is:

1. A method for assembling a theater comprising: providing a surface for supporting the weight of a modular auditorium within a building structure; assembling the modular auditorium by providing a plurality of nominal inventory portions, each nominal inventory portions comprising: a prefabricated base portion; and a prefabricated tier section for assembly to the base portion; positioning the prefabricated base portion on the surface; and fastening the prefabricated tier section to the base portion to form a self supporting modular auditorium structure that does not require lateral support from the building structure other than the ground surface; wherein the prefabricated tier section includes a tier floor having a first floor portion and a second floor portion cantilevered from opposed regions of a longitudinal beam.
2. The method of claim 1, further comprising providing a stage or performance presentation area to the surface.
3. The method of claim 1, further comprising configuring the modular auditorium to accommodate patrons at viewing

16

areas from which the patrons are able to watch a performance on the stage or performance presentation area.

4. The method of claim 1, wherein the surface is a prepared ground surface.

5. The method of claim 1, wherein the surface is a man-made surface.

6. The method of claim 1, wherein the first floor portion, and the second floor portion include an interface for accommodating a chair and for lifting the at least one tier section.

7. The method of claim 1, wherein the first floor portion and the second floor portion are non-movable relative to the base portion.

8. The method of claim 1, wherein the prefabricated base portion includes a base portion vertical beam and the prefabricated tier section includes a tier section vertical beam.

9. The method of claim 8, wherein the fastening includes fastening the base portion vertical beam to the tier section vertical beam.

10. The method of claim 9, wherein flange extensions secure the base portion vertical beam to the tier section vertical beam end-to-end without welding.

11. A theater comprising:

a modular auditorium disposed on a surface for supporting the weight of a modular auditorium within a building structure, the modular auditorium comprising: a plurality of nominal inventory portions, each nominal inventory portions comprising:

a prefabricated base portion; and

a prefabricated tier section for assembly to the prefabricated base portion;

wherein the modular auditorium, when assembled, is self supporting and does not require lateral support from a building structure other than the surface;

wherein the prefabricated tier section includes a tier floor having a first floor portion and a second floor portion cantilevered from opposed regions of a longitudinal beam.

12. The theater of claim 11, further comprising a stage or performance presentation area on the surface.

13. The theater of claim 11, wherein the modular auditorium is configured to accommodate patrons at viewing areas from which the patrons are able to watch a performance on the stage or performance presentation area.

14. The theater of claim 11, wherein the surface is a prepared ground surface.

15. The theater of claim 11, wherein the surface is a man-made surface.

16. The theater of claim 11, wherein the first floor portion, and the second floor portion include an interface for accommodating a chair and for lifting the at least one tier section.

17. The theater of claim 11, wherein the first floor portion and the second floor portion are non-movable relative to the base portion.

18. The theater of claim 11, wherein the prefabricated base portion includes a base portion vertical beam and the prefabricated tier section includes a tier section vertical beam.

19. The theater of claim 11, further comprising flange extensions arranged and disposed to secure the base portion vertical beam to the tier section vertical beam end-to-end without welding.

20. The theater of claim 11, further comprising a back wall constructed with passageways for providing electrical wiring, conveying ventilation air and providing egress/ingress for spectators to each prefabricated tier section.

21. The theater of claim 11, wherein each nominal inventory portion is configured to be transportable and positioned for assembly with other nominal inventory portions by a forklift machine.

22. The theater of claim 11, wherein prefabricated tier section includes seats and handrails.

* * * * *