



US011320130B2

(12) **United States Patent**
Kuenzler

(10) **Patent No.:** **US 11,320,130 B2**

(45) **Date of Patent:** **May 3, 2022**

(54) **ILLUMINATION DEVICE**

21/15 (2013.01); F21W 2121/00 (2013.01);
F21W 2131/406 (2013.01); F21Y 2105/14
(2016.08); F21Y 2113/17 (2016.08); F21Y
2115/10 (2016.08)

(71) Applicant: **GLP German Light Products GmbH**,
Karlsbad (DE)

(72) Inventor: **Udo Kuenzler**, Karlsbad (DE)

(58) **Field of Classification Search**
CPC ... F21V 23/0407; F21V 21/30; F21Y 2115/10
See application file for complete search history.

(73) Assignee: **GLP German Light Products GmbH**,
Karlsbad (DE)

(*) Notice: Subject to any disclaimer, the term of this
patent is extended or adjusted under 35
U.S.C. 154(b) by 0 days.

(56) **References Cited**

U.S. PATENT DOCUMENTS

8,901,848 B2 * 12/2014 Watanabe F21S 8/04
315/294
2005/0128751 A1 * 6/2005 Roberge F21K 9/00
362/276
2008/0002413 A1 * 1/2008 Wang F21V 14/02
362/341
2008/0062681 A1 * 3/2008 Belliveau F21S 10/007
362/231

(Continued)

(21) Appl. No.: **15/920,498**

(22) Filed: **Mar. 14, 2018**

(65) **Prior Publication Data**

US 2019/0101273 A1 Apr. 4, 2019

FOREIGN PATENT DOCUMENTS

(30) **Foreign Application Priority Data**

Sep. 29, 2017 (DE) 20 2017 005 050.1

DE 202015009240 U1 12/2016

(51) **Int. Cl.**

F21S 10/06 (2006.01)
F21S 10/02 (2006.01)
F21V 21/15 (2006.01)
F21Y 115/10 (2016.01)
F21V 23/04 (2006.01)
F21V 21/30 (2006.01)
F21V 23/00 (2015.01)
F21W 121/00 (2006.01)
F21Y 105/14 (2016.01)
F21Y 113/17 (2016.01)
F21W 131/406 (2006.01)

Primary Examiner — Alexander K Garlen

Assistant Examiner — Eric T Eide

(74) *Attorney, Agent, or Firm* — Eschweiler & Potashnik,
LLC

(52) **U.S. Cl.**

CPC **F21V 23/0407** (2013.01); **F21S 10/023**
(2013.01); **F21S 10/06** (2013.01); **F21V 21/30**
(2013.01); **F21V 23/003** (2013.01); **F21V**

(57) **ABSTRACT**

An illumination device includes two illumination sections.
The first illumination section includes a plurality of illumina-
tion elements that are each configured to emit light in a
light spectrum, wherein the light spectrum is variable. The
second illumination section includes one or several illumina-
tion elements that are each configured to emit light in a
fixed light spectrum, wherein the fixed light spectrum is
white.

28 Claims, 6 Drawing Sheets

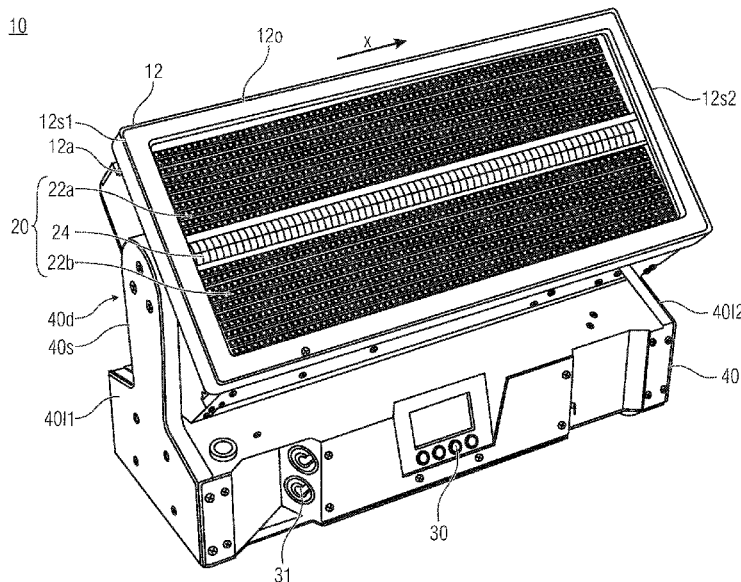

(56)

References Cited

U.S. PATENT DOCUMENTS

2008/0259596 A1 10/2008 Biebl
2016/0273748 A1* 9/2016 Salm F21V 21/30
2016/0305631 A1 10/2016 Hansen
2016/0323972 A1* 11/2016 Bora F21V 7/00
2017/0352605 A1* 12/2017 Bilan H01L 23/3672

* cited by examiner

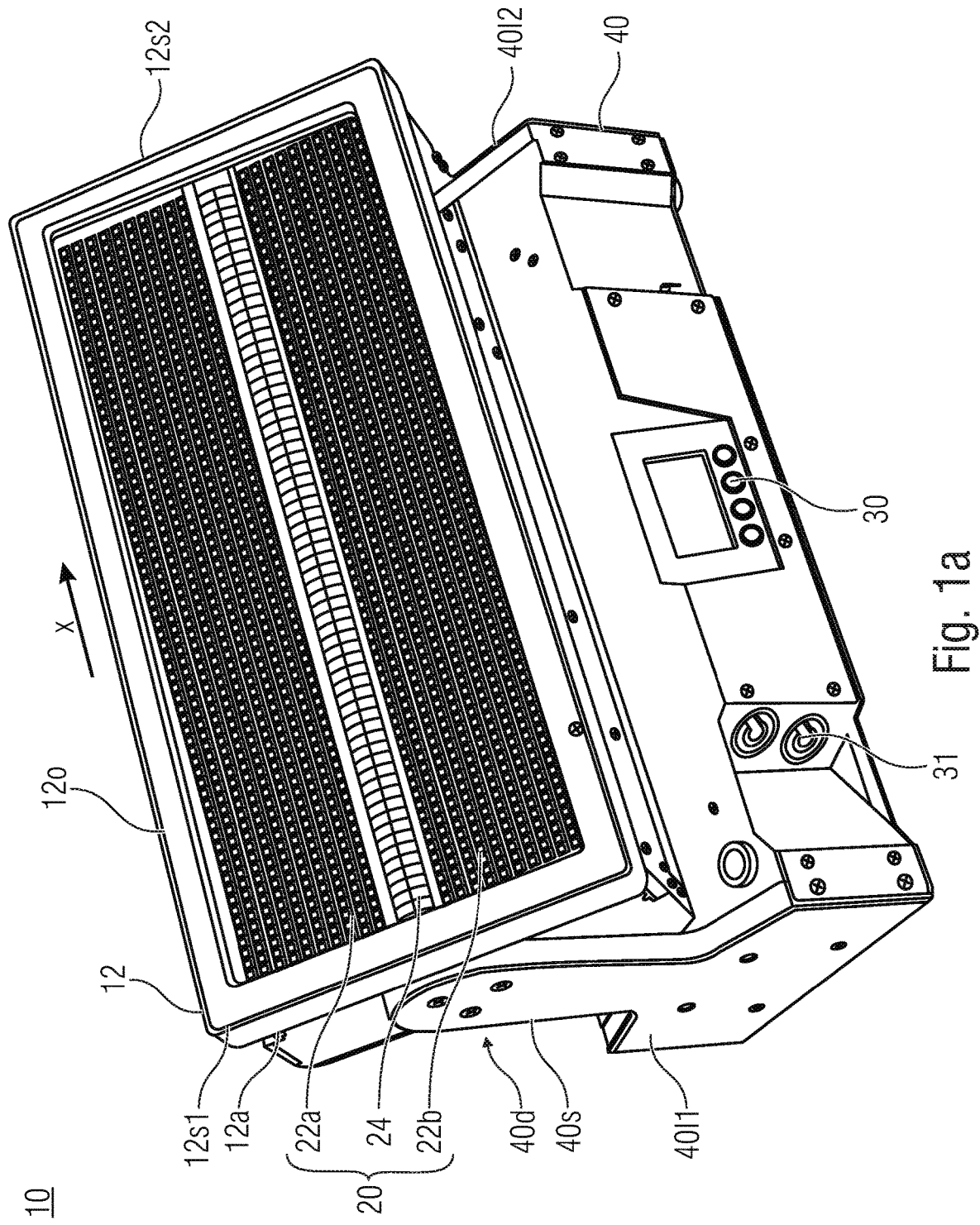

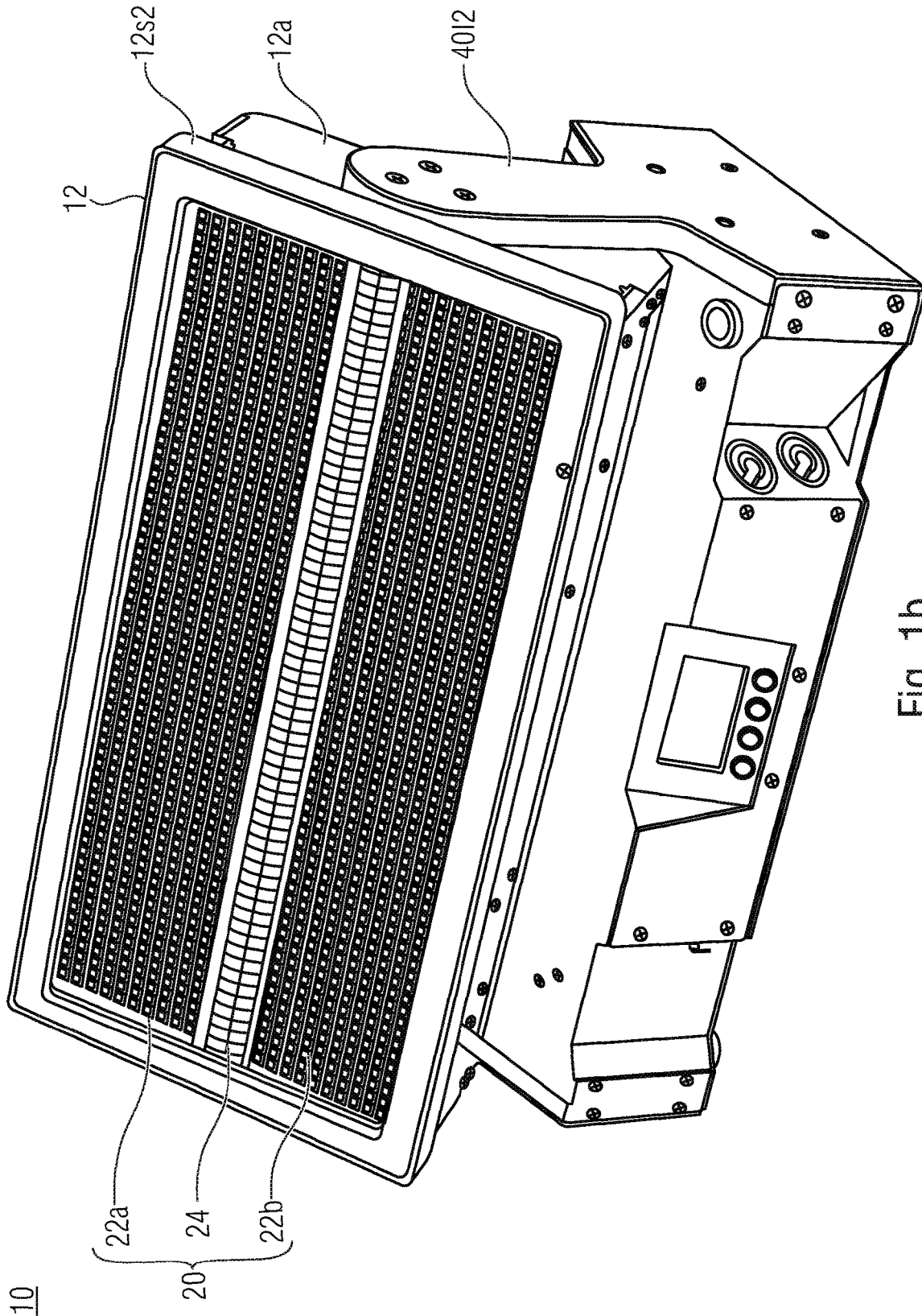

Fig. 1b

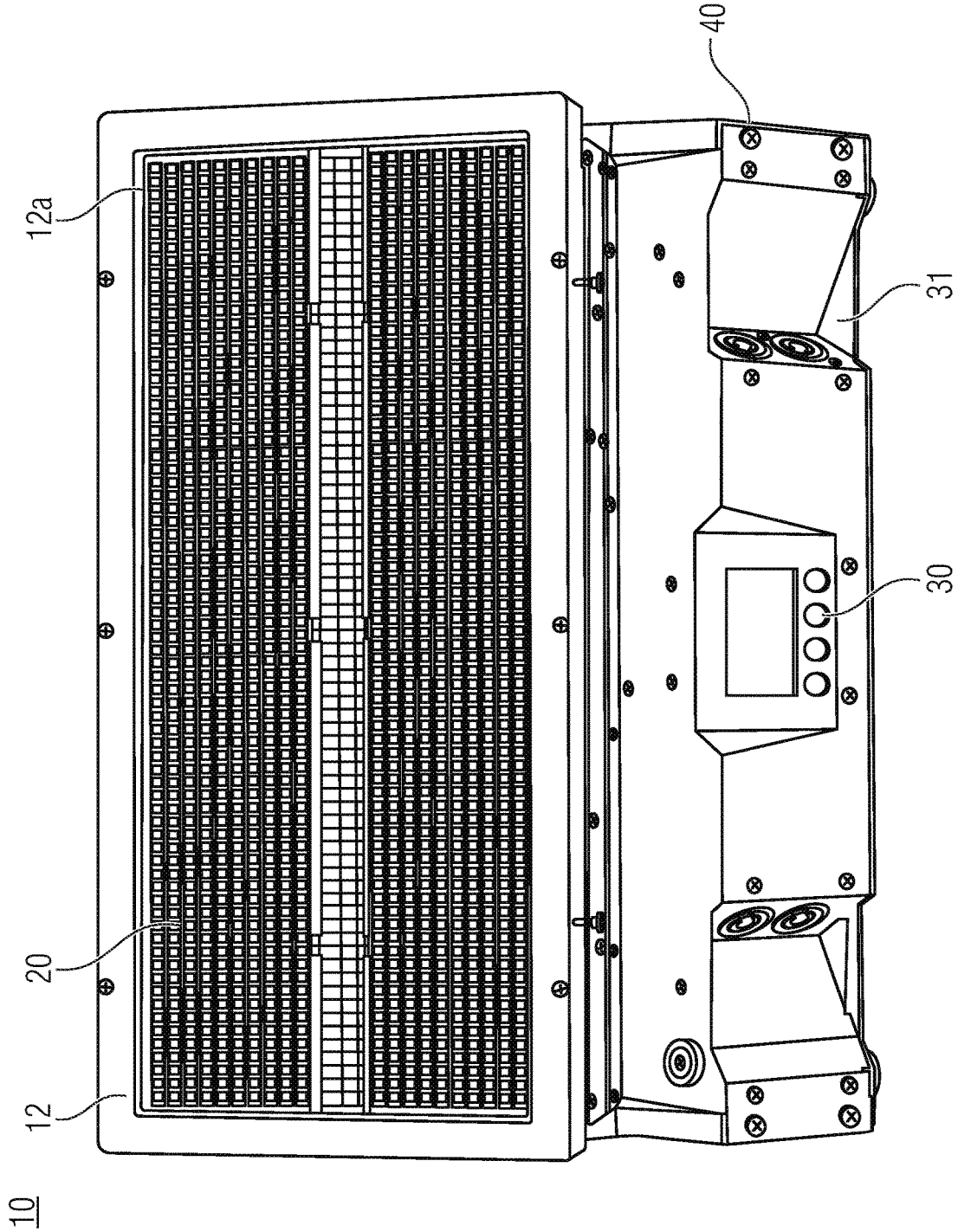

Fig. 1C

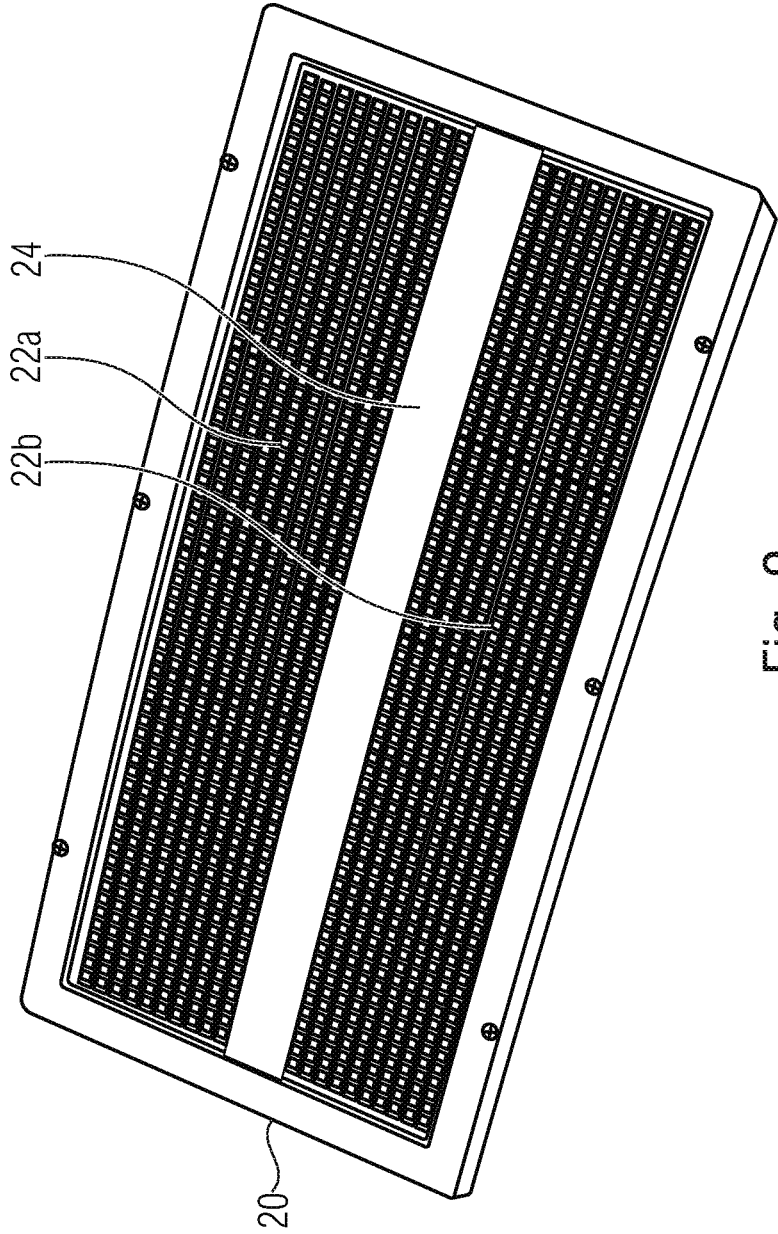

FIG. 2

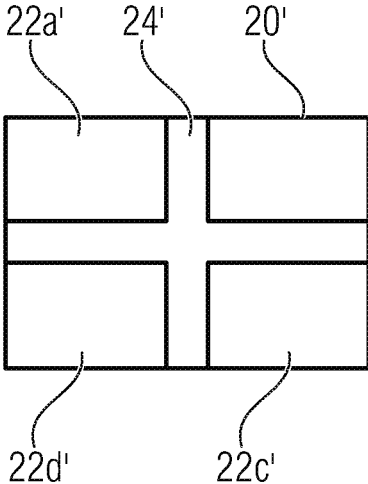

Fig. 3a

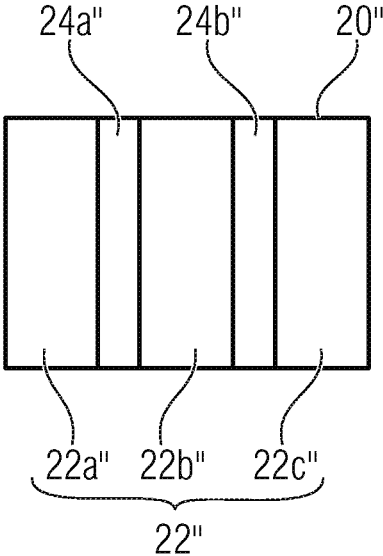

Fig. 3b

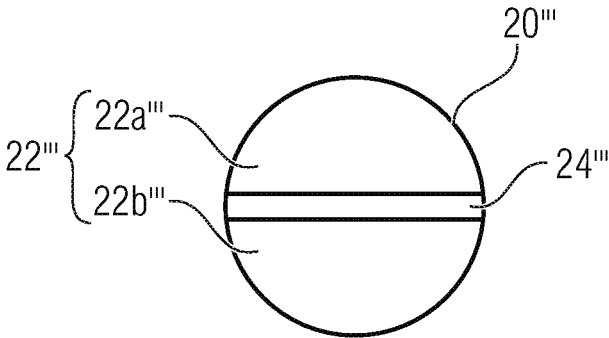

Fig. 4a

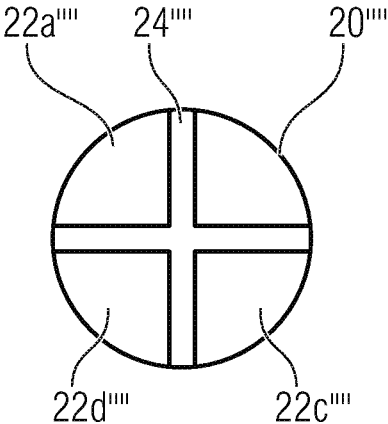

Fig. 4b

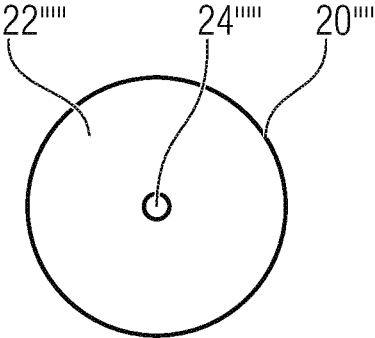

Fig. 4c

ILLUMINATION DEVICE

CROSS-REFERENCE TO RELATED APPLICATIONS

This application claims priority from German Utility Model Application No. 20 2017 005 050.1, which was filed on Sep. 29, 2017, and is incorporated herein in its entirety by reference. Embodiments of the present invention relate to an illumination device and to a panel having at least two illumination sections. Some embodiments relate to a stroboscope.

BACKGROUND

A stroboscope is a flash unit emitting light flashes at regular time intervals, whereby, in a dark environment, movements appear chopped as a sequence of still images. The time intervals and the frequency, respectively, can typically be varied in the range between 0.5 and 100 Hz or normally between 1 and 50 Hz. The flash period is in the order of below 5 ms or even less than 1 ms.

According to conventional technology, xenon flash lamps or light emitting diodes (LED) and LED arrays, respectively, are frequently used as light source. Due to the need for high light energy with simultaneously short light pulse, these light sources are particularly well-suited. The need for high light energy is frequently met by the fact that the stroboscope light sources emit white light that consists, in a physical sense, of portions of all wavelengths of the visible spectral range. An equi-energy mixture is desired, which is virtually impossible to realize, so that, in a broader sense, white light also means daylight, such as sunlight or norm light having a specific color temperature.

In illumination technology, stroboscopes are frequently used in combination with other illumination fixtures for colored stage lighting. In such illumination devices, either standard illumination means with color screens or colored LEDs, such as RGB LEDs are used. RGB LEDs can be varied in color depending on their control. In that way, RGB LEDs can also emit white light. However, due to their technical characteristics, RGB LEDs do not have the energy density for realizing stroboscope effects. Thus, there is a need for an improved approach.

SUMMARY

According to an embodiment, an illumination device may have: a first illumination section with a plurality of illumination elements that are each configured to emit light in a light spectrum, wherein the light spectrum is variable; a second illumination section with one or several illumination elements that are each configured to emit light in a fixed light spectrum, wherein the fixed light spectrum is white.

According to another embodiment, an illumination panel may have: a first illumination section with a plurality of illumination elements that are each configured to emit light in a light spectrum, wherein the light spectrum is variable; a second illumination section with a plurality of illumination elements that are each configured to emit light with a fixed light spectrum, wherein the fixed light spectrum is white.

Embodiments of the present invention provide an illumination device having a first and a second illumination section. The first illumination section includes a plurality of illumination elements, such as LEDs or RGB LEDs that are configured to emit light in a light spectrum, wherein the light spectrum is variable. The second illumination section

includes one or several illumination elements, such as white LEDs or also other illumination elements configured to emit light in a white fixed light spectrum.

According to embodiments, the first illumination section is geometrically divided into two partial sections, such that, according to further embodiments, the second illumination section is arranged between the two partial sections of the first illumination section (e.g. in the center). In other words, this arrangement can be described such that a single tube element, respectively, and tubular illumination element or illumination array for white light (for example a stroboscope) is used, which is framed by two LED fields of variable color. When it is assumed that LEDs are used both for the first and the second illuminations sections, these illumination elements can be arranged in a common panel.

The core idea of this invention is the finding that when using two different types of illumination elements in a common illumination device or in a common panel, the advantages of both types can be combined, such that the illumination device can be used both as stroboscope and (simultaneously) also as colored illumination device. Such a system offers the advantage of high functionality and also the realization of light effects with high light energy. Further, blurring and fading effects can also be realized.

According to embodiments, the illumination device includes a control that is configured to control the first illumination section with at least 20 Hz, at least 30 Hz and/or at least 50 Hz for emitting regular stroboscope light flashes. Stroboscope light means white high-energy light flashes. According to embodiments, this control frequency can be varied between 0.5 Hz and the maximum control frequency. The same control can also be provided for the first illumination section, such that the same can emit regular light flashes of a defined color or also with white light. The two illumination sections can be controlled synchronously or asynchronously, such that the energy density advantageously increases during synchronous control.

As already mentioned above, in an embodiment for the first illumination section, RGB LEDs are used, e.g. at least 1000 RGB LEDs. For the second illumination section, LEDs can be used as well, such as soft LEDs in the order of between 1000 and 500 LEDs. From a thermal point of view, the usage of LEDs is reasonable, since LEDs are very efficient and the high energy density causes few thermal problems due to the high concentrated light energy.

According to embodiments, both the first illumination section and also the second illumination section can be divided into fields that can be controlled separately. For example, it would be possible that the first section comprises 10 fields or 12 fields, while the second illumination section comprises 2 or more (e.g. 12) fields. Here, for example, different colors and different luminosities are possible, such that moving light can be realized as well.

According to further embodiments, the illumination device includes a longitudinal housing into which, for example, rectangular illumination sections, e.g. of a panel, are integrated. The longitudinal housing is limited in its longitudinal extension by two lateral faces. According to a further embodiment, additionally, a longitudinal stand is provided comprising bearing blocks that are also limited in their longitudinal extension by lateral faces. The bearing blocks include pivot joints via which the longitudinal housing is connected to the stand, such that the longitudinal housing is rotatably supported around a longitudinal axis extending parallel to the stand and the longitudinal housing, respectively. According to further embodiments, this rotation for example by up to 180° or 190° can be motor-driven.

Here, means for motor-driven pivoting, such as a motor with a toothed belt and/or a gear are provided in one of the bearing blocks.

A further embodiment relates to an illumination panel with the two above-discussed illumination sections.

BRIEF DESCRIPTION OF THE DRAWINGS

Embodiments of the present invention will be detailed subsequently referring to the appended drawings, in which:

FIGS. 1a-c is a schematic illustration of an illumination device according to an embodiment in three different perspective illustrations;

FIG. 2 is a schematic illustration of a panel according to an embodiment;

FIGS. 3a, 3b are schematic illustrations of a rectangular panel according to further embodiments; and

FIGS. 4a-4c are schematic illustrations of a round panel according to further embodiments.

DETAILED DESCRIPTION

Before embodiments of the present invention will be discussed below based on accompanying drawings, it should be noted that the same elements and structures are provided with the same reference numbers, such that the description of the same is inter-applicable and inter-exchangeable.

FIG. 1a shows a three-dimensional illustration of an illumination device 10 including a longitudinal housing 12 in this embodiment. FIG. 1b shows a further three-dimensional view of the same illumination device 10. The longitudinal housing has a rectangular opening 120 in which a panel 20 is inserted. FIG. 1c shows the front view of the panel 20 in the housing 12.

The panel 20 includes two illumination sections, namely illumination section 22 and 24. In this embodiment, the illumination section 22 is formed by two partial sections 22a and 22b. All sections 22a, 24 and 22b extend longitudinally along the longitudinal illumination device 10 and along the longitudinal housing 12, respectively. As can in particular be seen in FIG. 1c, the panel 20 is rectangular and has, for example, an aspect ratio of 2:1 (length to width).

According to embodiments, the three sections 22a, 22b and 24 are arranged with respect to one another as follows: all three sections 22a, 22b and 24 extend longitudinally along the longitudinal axis. Here, for example, the two partial sections 22a and 22b are of approximately the same size. The section 24 is provided between these two partial sections 22a and 22b. Due to the fact that the two sections are of the same size, a section 24 is centered with respect to the two partial sections 22a and 22b.

The section 22a+22b of the panel includes a plurality of illumination elements, here LEDs or in particular RGB LEDs. Generally, these are illumination elements that are variable with respect to their color spectrum. In this embodiment, the second section 24 is also formed by LEDs, but LEDs with a fixed light spectrum, in particular a white light spectrum. With regard to its geometrical arrangement, this second section emulates a fluorescent tube or flash tube, i.e. the same has a high aspect ratio of, for example, 5:1 (length to width). According to further embodiments, in particular this second section can also be formed by a standard fluorescent tube. Both section 22a+22b and section 24 are formed by a plurality of illumination elements that are repeated both in the longitudinal direction in the respective section as well as in the width direction of the respective

section. Section 24 comprises, for example, three or four illumination elements in width and approximately 60 illumination elements in length.

The panel can be provided with a control controlling the three sections 22a, 22b and 24 accordingly. Here, the control can be implemented such that the RGB LEDs of the sections 22a and 22b can be varied in color. This control can be implemented independently of section 24. This section can also be adjusted with a specific control frequency, such that flashing effects are possible. The control controls the section 24 advantageously like a stroboscope, i.e. with a repeating frequency in the range of 0.5 to 60 Hz or in particular in the range of 1 to 30 Hz. As already explained above, the emitted light flashes have a very short illumination period but also high illumination intensity. This section illumination section 24 can also be controlled independently of the first illumination section 22a+22b. According to a further embodiment, a common control would be possible, such that, for example, both by means of the illumination elements of section 22a and 22b and also by means of the illumination elements of section 24, simultaneous lighting or simultaneous emission of light flashes is possible. The same can also be performed asynchronously, such that color and white stroboscope light flashes are emitted alternately. Thereby, fading effects become possible. By using only LEDs, thermal problems as they typically occur in glass bulb spotlights can be reduced as well.

According to an embodiment, both sections 22a, 22b and section 24 can be divided into sub-sections, such as 12 sub-sections per partial section, such that individual fields can be controlled separately. In other words, the plurality of illumination elements are grouped per illumination section 22a, 22b and 24, such that the same are controlled together. This enables moving light effects that can also move beyond the stroboscope range 24 starting from a continuous panel 20.

Here, it should be noted that, according to embodiments, the section 24 normally comprises approximately 100 to 500 LEDs, such as 216 LEDs, while the complete section 22a+22b normally comprises more than 1000 LEDs, such as 1440 LEDs. The entire panel can receive power, for example, in the order of 1 kW or 1.2 kW and the same can have a lighting efficiency of up to 90% due to the used LED technologies.

Regarding the control it should be noted that the same is controllable via standard protocols, such as DMX-512, ARTNET or RDM. According to embodiments, the illumination device 10 can also include a display with a control. This display is indicated by reference number 30. According to embodiments, the control comprises means for temperature control and in particular for heating control. For remote control of the control, apart from the display a signal connector, such as an XMR-5-Pin connector can be provided (cf. reference number 31).

According to a further embodiment, the longitudinal housing 12 can have a specific shape. As, for example, shown in FIG. 1a, the longitudinal extension (cf. x direction) of the housing is limited on the left and right by the two lateral faces 12s1 and 12s2. Additionally, the illumination device includes a stand 40, comprising, in this embodiment, two bearing blocks at the end of the longitudinal extension. These bearing blocks are indicated by reference numbers 40/1 and 40/2. The bearing blocks have pivot joints 40d, via which the longitudinal illumination housing 12 is rotationally supported with respect to the stand 40. Thereby, the housing 12 and hence the panel 20 and the illumination sections 22a, 22b and 24, respectively, can be pivoted

around a longitudinal axis. This longitudinal axis extends along the longitudinal extension of the longitudinal stand **40** and the longitudinal housing **12** and parallel to the direction *x*, respectively.

In order that, according to embodiments, the longitudinal extension of the illumination device **10** is defined not by the stand **40** but in particular by the illumination element **12** with its almost full-surface illumination panel **20**, the illumination housing **12** includes, both on the side of the lateral face **12s1** and on the side of the lateral face **12s2**, a recess **12a** in which the bearing blocks **40/1** and **40/2** are arranged. In the *x* direction, the recess **12a** is of a depth that is deeper than or is the same as the thickness of each bearing block **40/1** and **40/2**. This has the effect that the lateral faces **40s** of the bearing block terminate in a planar manner with the lateral faces **12s1** or in an essentially planar manner (i.e. up to 5 mm offset, offset 5 mm). Further, the dimensioning of the recess **12a** can be designed such that the lateral faces **40s** of the bearing blocks are recessed with respect to the lateral faces **12s1** of the housing **12**. This has again the same effect, namely that the longitudinal extension (in *x* direction) is defined by the housing **12** and not by the stand. It is an advantage of such an arrangement that several illumination elements **10** can be arranged beside one another and can be easily positioned since the same are set up with their front faces adjoined to one another. With regard to the set-up it should be noted that the illumination device **10** can practically be used in any set-up. In that way, a set-up by means of the stand **40** can be implemented and, on the other hand, the stand **40** can also be installed on a traverse or similar support devices.

Generally, concerning the dimensioning of the illumination device, it should be noted that the same has, for example, a length of more than 30 or even 40 cm (for example 390 mm), while the width is in the range of 10 to 20 cm (for example 150 mm). The height is in the range of 20 to 30 cm (e.g. 251 mm).

With reference to FIG. 2, a further embodiment, namely the panel **20** will be discussed. The panel **20** includes a first illumination section formed by two partial sections **22a** and **22b** as well as a second illumination section **24**. As discussed with reference to FIGS. 1a-c, this second illumination section is also provided in a centered manner. The panel includes a plurality of illumination elements that are normally arranged in an equidistant manner, wherein the illumination elements in section **24** are the illumination elements of a type where a fixed (predefined) color spectrum, e.g. a white color spectrum, is emitted, while the illumination elements in the section **22a** and **22b** are variable in each color spectrum. The three sections **22a**, **22b** and **22s** are again implemented in a longitudinal manner. According to further embodiments, the arrangement and the longitudinal arrangement, respectively, of the sections **22a**, **22b** and **24** can also be implemented differently. Thus, for example, a second section **24** and a third section **22** can be provided, which then alternate accordingly. Instead of the longitudinal orientation of sections **22a**, **22b** and **24**, vertical orientation would also be possible.

According to a further embodiment, the section **24** can be formed by different elements, such as a standard xenon tube arranged between the sections **22a** and **22b**. Alternatively, it would also be possible that this tube is provided behind the first illumination section (undivided illumination section), such that the tube radiates through the first illumination section.

FIG. 3a shows a rectangular panel **20'** with a cross-shaped second illumination section **24'** and, starting from this cen-

trally arranged cross-shaped second illumination section **24'**, four first illumination sections **22a'** to **22b'** (each rectangular) arranged in the corners.

FIG. 3b shows a further variation of a rectangular panel **20''** with two second illumination sections **24a''** and **24b''** that are not arranged longitudinally but transversally to the longitudinal direction such that the first section **22''** is divided in three sub-sections.

FIG. 4a assumes a rectangular panel **20'''**, wherein a line-shaped second section **24'''** (for example aligned in longitudinal direction) divides the first section **22'''** into two crescent-shaped first sections **22a'''** and **22b'''**.

FIG. 4b also assumes a round panel **20''''**, wherein here again a cross-shaped second section **24''''** is provided which divides the first section in four circular segment-shaped sections **22a''''** to **22b''''**.

The panel **20''''** illustrated in FIG. 4c is also implemented as a round panel and includes a centrally arranged point-shaped second section **24''''** as well as a first section **22''''** extending around the central section **24''''**.

All panels **20'** to **20''''** can be installed in the above-discussed illumination unit and in the above-explained housing, respectively. According to embodiments, the panels **20'** and **20''** can be configured in a square manner instead of in a rectangular/longitudinal manner, such that the housing is then adapted accordingly. For panels **20'''** to **20''''**, respectively, a corresponding round housing is provided.

In these doubly symmetrical panels **20'** to **20''''**, according to embodiments, the housing mechanics can also be extended, such that biaxial pivoting is provided.

Generally, it should be noted that both the shape of the panels and the sections can vary according to embodiments (e.g. triangular panel, diagonal sections or the same).

While this invention has been described in terms of several advantageous embodiments, there are alterations, permutations, and equivalents which fall within the scope of this invention. It should also be noted that there are many alternative ways of implementing the methods and compositions of the present invention. It is therefore intended that the following appended claims be interpreted as including all such alterations, permutations, and equivalents as fall within the true spirit and scope of the present invention.

The invention claimed is:

1. Illumination device comprising:

- a common light emitting diode (LED) panel, comprising:
 - a first illumination section with a plurality of LEDs that are each configured to emit light in a light spectrum, wherein the light spectrum of each of the plurality of LEDs is variable; and
 - a second illumination section with LEDs that are each configured to emit light in a fixed white light spectrum,
- wherein the second illumination section is configured to emit the fixed white light spectrum in the form of stroboscope light flashes,
- wherein the first illumination section is geometrically divided into two partial sections,
- wherein the second illumination section is arranged between the two partial sections of the first illumination section, and
- wherein the two partial sections of the first illumination section and the second illumination section are arranged in parallel with one another and have the same length.

2. Illumination device according to claim 1, wherein the two partial sections of the first illumination section and the

second illumination section extend in parallel with one another along a longitudinal axis of the panel.

3. Illumination device according to claim 1, wherein the second illumination section is arranged between and/or centered between the two partial sections of the first illumination section.

4. Illumination device according to claim 1, wherein the first and/or the second illumination section is configured to emit the respective light in the form of stroboscope light flashes, such that the illumination device forms a stroboscope.

5. Illumination device according to claim 4, wherein the illumination device comprises a control that is configured to control the second illumination section with at least 20 Hz, with at least 30 Hz and/or at least 50 Hz to emit regular stroboscope light flashes.

6. Illumination device according to claim 5, wherein the control is configured to vary a control frequency between 0.5 Hz and a maximum control frequency.

7. Illumination device according to claim 5, wherein the control is configured to control the first illumination section with at least 20 Hz, at least 30 Hz or at least 50 Hz in order to emit regular light flashes and/or stroboscope light flashes.

8. Illumination device according to claim 7, wherein the control is configured to control the first illumination section and the second illumination section in a synchronous or asynchronous manner.

9. Illumination device according to claim 1, wherein the first illumination section comprises illumination elements, and the illumination elements of the first illumination section comprise RGB LEDs.

10. Illumination device according to claim 1, wherein the first illumination section comprises at least 1000 illumination elements.

11. Illumination device according to claim 1, wherein the first illumination section is divided into at least 10 fields.

12. Illumination device according to claim 1, wherein the second illumination section is formed as stroboscope tube or in the form of a tube.

13. Illumination device according to claim 1, wherein the second illumination section comprises several white LEDs as illumination elements.

14. Illumination device according to claim 13, wherein the second illumination section comprises more than 100 white LEDs and/or wherein the second illumination section comprises less than 500 white LEDs.

15. Illumination device according to claim 1, wherein the second illumination section comprises several illumination elements, and wherein the several illumination elements of the second illumination section are divided into at least two fields that can be separately controlled.

16. Illumination device according to claim 15, wherein the second illumination section is divided into at least three fields.

17. Illumination device according to claim 1, wherein the illumination device comprises a longitudinal housing that is limited by two lateral faces in a longitudinal extension.

18. Illumination device according to claim 17, wherein the illumination device comprises a longitudinal stand extending parallel to the longitudinal housing; and

wherein the longitudinal stand comprises two bearing blocks with rotational joints via which the longitudinal housing is supported in a pivotable manner around a longitudinal axis extending parallel to the longitudinal stand and the longitudinal housing with respect to the longitudinal stand.

19. Illumination device according to claim 18, wherein the longitudinal housing comprises two lateral recesses in which the two bearing blocks are arranged, such that the lateral faces of the longitudinal housing and lateral faces which limit the longitudinal extension of the longitudinal stand with its bearing blocks in the longitudinal extension are terminated in a planar manner with respect to one another, or

wherein the lateral faces of the longitudinal stand are recessed with respect to the lateral faces of the longitudinal housing.

20. Illumination device according to claim 18, wherein a unit for motor-driven pivoting and/or a motor with a toothed belt are provided in at least one of the bearing blocks.

21. Illumination device according to claim 18, wherein the longitudinal housing can be pivoted around the longitudinal axis by at least 180° or by 190°.

22. Illumination device according to claim 1, wherein the illumination device comprises a housing and a stand, wherein the housing can be pivoted in a biaxial manner or can be pivoted in a biaxial motor-driven manner with respect to the stand.

23. Illumination device according to claim 1, wherein the common LED panel is rectangular or round.

24. A light emitting diode (LED) panel, comprising:

a first illumination section with a plurality of LEDs that are each configured to emit light in a light spectrum, wherein the light spectrum of each of the plurality of LEDs is variable; and

a second illumination section with a plurality of LEDs that are each configured to emit light with a fixed light spectrum,

wherein the fixed light spectrum is white,

wherein the second illumination section is configured to emit the fixed white light spectrum in the form of stroboscope light flashes,

wherein the first illumination section is geometrically divided into two partial sections,

wherein the second illumination section is arranged between the two partial sections of the first illumination section, and

wherein the two partial sections of the first illumination section and the second illumination section are arranged in parallel with one another and have the same length.

25. Panel according to claim 24,

wherein the second illumination section is arranged in a centered manner between the two partial sections of the first illumination section; and

wherein the two partial sections and the second illumination section extend in parallel with one another along a longitudinal axis of the panel.

26. Illumination device according to claim 1, wherein the first illumination section comprises a plurality of illumination elements, and wherein the plurality of illumination elements of the first illumination section are geometrically divided into fields that can be separately controlled, wherein each field is of variable color.

27. Illumination device according to claim 26, wherein each field comprises one or more RGB LEDs.

28. Illumination device according to claim 1, wherein illumination device is a stage illumination device entity.