



(12) **United States Patent**
Hoffend, III

(10) **Patent No.:** **US 10,544,018 B2**
(45) **Date of Patent:** **Jan. 28, 2020**

- (54) **LIFT ASSEMBLY WITH LOAD CELLS**
- (71) Applicant: **Electronic Theatre Controls, Inc.**,
Middleton, WI (US)
- (72) Inventor: **Donald A. Hoffend, III**, Annandale, VA
(US)
- (73) Assignee: **Electronic Theatre Controls, Inc.**,
Middleton, WI (US)
- (*) Notice: Subject to any disclaimer, the term of this
patent is extended or adjusted under 35
U.S.C. 154(b) by 0 days.
- (21) Appl. No.: **15/716,830**
- (22) Filed: **Sep. 27, 2017**
- (65) **Prior Publication Data**
US 2018/0029854 A1 Feb. 1, 2018

Related U.S. Application Data

- (63) Continuation of application No. 15/033,804, filed as
application No. PCT/US2014/066573 on Nov. 20,
2014, now Pat. No. 9,908,755.
(Continued)
- (51) **Int. Cl.**
B66D 1/39 (2006.01)
A63J 1/02 (2006.01)
B66D 1/30 (2006.01)
- (52) **U.S. Cl.**
CPC **B66D 1/39** (2013.01); **A63J 1/02**
(2013.01); **B66D 1/30** (2013.01)
- (58) **Field of Classification Search**
CPC ... B66D 1/39; B66D 1/30; B66D 1/36; B66D
1/00; B66D 1/26; B66D 1/38; A63J 1/02;
A63J 1/028
See application file for complete search history.

- (56) **References Cited**
- U.S. PATENT DOCUMENTS
- 190,811 A * 5/1877 Bevelander B65H 75/4402
242/397.2
- 969,598 A * 9/1910 Buttles B65H 75/4407
242/389
- (Continued)
- FOREIGN PATENT DOCUMENTS
- DE 10117466 10/2002
- JP 06-32589 2/1994
- (Continued)
- OTHER PUBLICATIONS
- International Search Report for Application No. PCT/US2014/
066573 dated Jun. 12, 2015 (7 pages).
(Continued)
- Primary Examiner* — Michael E Gallion
(74) *Attorney, Agent, or Firm* — Michael Best &
Friedrich LLP

(57) **ABSTRACT**

A lift assembly comprises a base, a drive mechanism, a flexible drive element extending from the drive mechanism along a fleet axis, and a sheave directing the drive element from the fleet axis to an output axis. The sheave is coupled to the base at a first sheave mount aligned with the fleet axis. The assembly can further include a second sheave mount aligned with the fleet axis and configured to be coupled to the sheave to allow the sheave to be de-coupled from the first sheave mount and coupled to the second sheave mount, resulting in substantially no change in a fleet angle of the fleet axis. Preferably, the sheave is positioned on a first side of the fleet axis when coupled to the first sheave mount, and the sheave is positioned on a second side of the fleet axis (e.g., opposite the first side) when coupled to the second sheave mount.

20 Claims, 17 Drawing Sheets

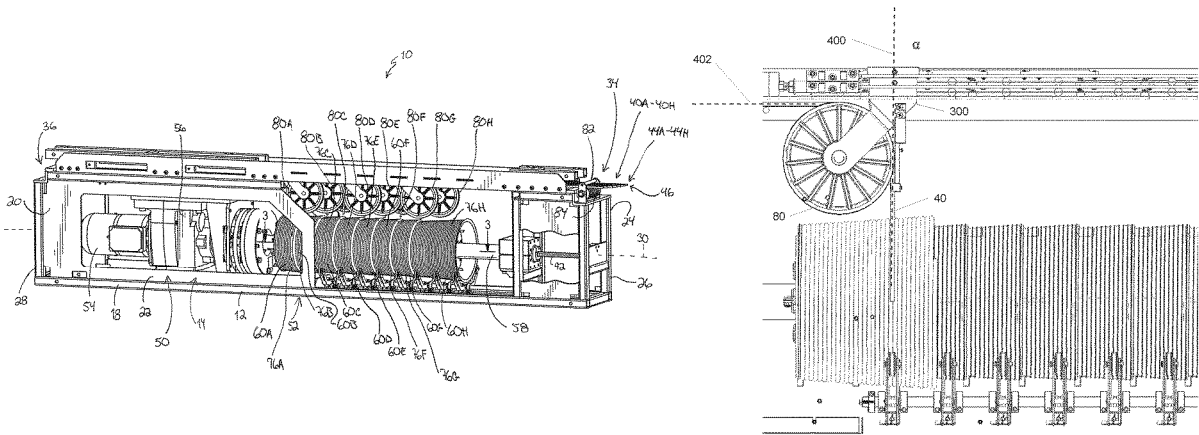

Related U.S. Application Data

(60) Provisional application No. 61/907,786, filed on Nov. 22, 2013.

8,684,336 B1 * 4/2014 Akerman E21B 17/07
 254/337
 9,242,186 B2 * 1/2016 Hoffend, III A63J 1/028
 9,260,279 B2 * 2/2016 Hoffend, III A63J 1/02
 9,340,396 B2 * 5/2016 Hoffend, III A63J 1/028
 9,908,755 B2 * 3/2018 Hoffend, III B66D 1/39
 2003/0030045 A1 * 2/2003 Hoffend, Jr. A63J 1/028
 254/288

(56) **References Cited**

U.S. PATENT DOCUMENTS

2,595,655 A * 5/1952 Hannay B65H 75/38
 137/355.2
 3,456,899 A * 7/1969 Burch B66D 1/39
 242/484
 4,303,237 A * 12/1981 Hoffend, Jr. B66D 1/26
 472/78
 4,324,386 A * 4/1982 Gagnon B66D 1/39
 254/288
 4,334,670 A * 6/1982 Kawabe B66D 1/38
 242/397.3
 4,492,363 A * 1/1985 Niskin B66D 3/06
 254/275
 4,606,527 A * 8/1986 Ziller A63J 1/028
 254/336
 4,778,121 A * 10/1988 Minnee B66D 1/38
 242/157.1
 5,106,057 A * 4/1992 Feller B66D 1/26
 254/283
 5,361,565 A * 11/1994 Bayer A63J 1/028
 254/270
 6,520,485 B1 * 2/2003 Soot A63J 1/028
 160/331
 6,634,622 B1 * 10/2003 Hoffend, Jr. A63J 1/028
 254/331
 7,111,803 B2 * 9/2006 Mott B66D 1/38
 242/397.4
 7,243,870 B2 * 7/2007 Pook A63J 1/028
 242/278
 7,293,762 B2 11/2007 Hoffend, Jr.
 7,484,712 B2 * 2/2009 Hossler A63J 1/028
 254/331
 7,562,863 B2 7/2009 Kochan et al.
 7,766,308 B2 8/2010 Kochan et al.
 7,854,423 B2 * 12/2010 Hoffend, Jr. A63J 1/028
 254/331
 8,596,616 B1 * 12/2013 Soot B66D 1/39
 254/334
 8,613,428 B2 12/2013 Hoffend, III
 8,636,265 B1 * 1/2014 Soot B66D 1/39
 254/334

2003/0111652 A1 * 6/2003 Hoffend, Jr. A63J 1/028
 254/331
 2004/0099852 A1 * 5/2004 Hoffend, Jr. A63J 1/028
 254/331
 2006/0163548 A1 * 7/2006 Kochan A63J 1/028
 254/278
 2009/0127527 A1 * 5/2009 Hoffend, III A63J 1/028
 254/338
 2012/0048152 A1 * 3/2012 Kim B66D 1/39
 108/20
 2013/0015315 A1 * 1/2013 Hoffend, III A63J 1/028
 248/542
 2014/0319308 A1 * 10/2014 Agazzi B66C 23/88
 248/542
 2015/0008381 A1 * 1/2015 Hausladen B66D 1/30
 254/288
 2015/0083879 A1 * 3/2015 Hoffend, III A63J 1/028
 248/332
 2015/0144851 A1 * 5/2015 Hoffend, III A63J 1/028
 254/278
 2015/0144852 A1 * 5/2015 Hoffend, III A63J 1/02
 254/316
 2016/0184731 A1 * 6/2016 Love A63J 1/028
 472/75
 2016/0368744 A1 * 12/2016 Hoffend, III A63J 1/02
 2018/0029854 A1 * 2/2018 Hoffend, III B66D 1/39

FOREIGN PATENT DOCUMENTS

KR 20090115645 11/2009
 KR 101219123 1/2013
 WO WO-2011133993 11/2011

OTHER PUBLICATIONS

Written Opinion for Application No. PCT/US2014/066573 dated Jun. 12, 2015 (9 pages).
 Examination Report issued from the European Patent Office for related Application No. 14812068.6-1017 dated Jan. 18, 2019 (5 pages).

* cited by examiner

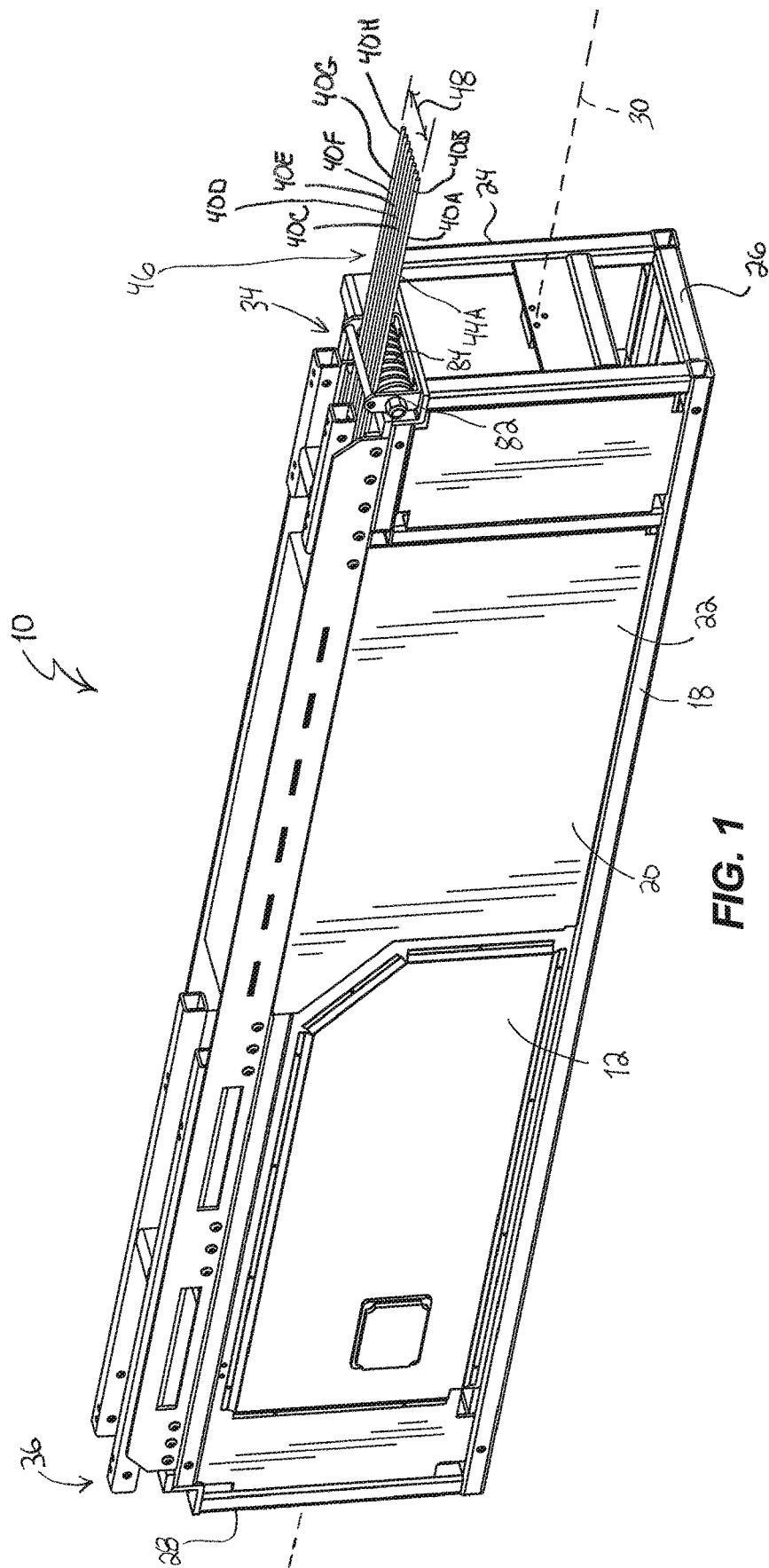
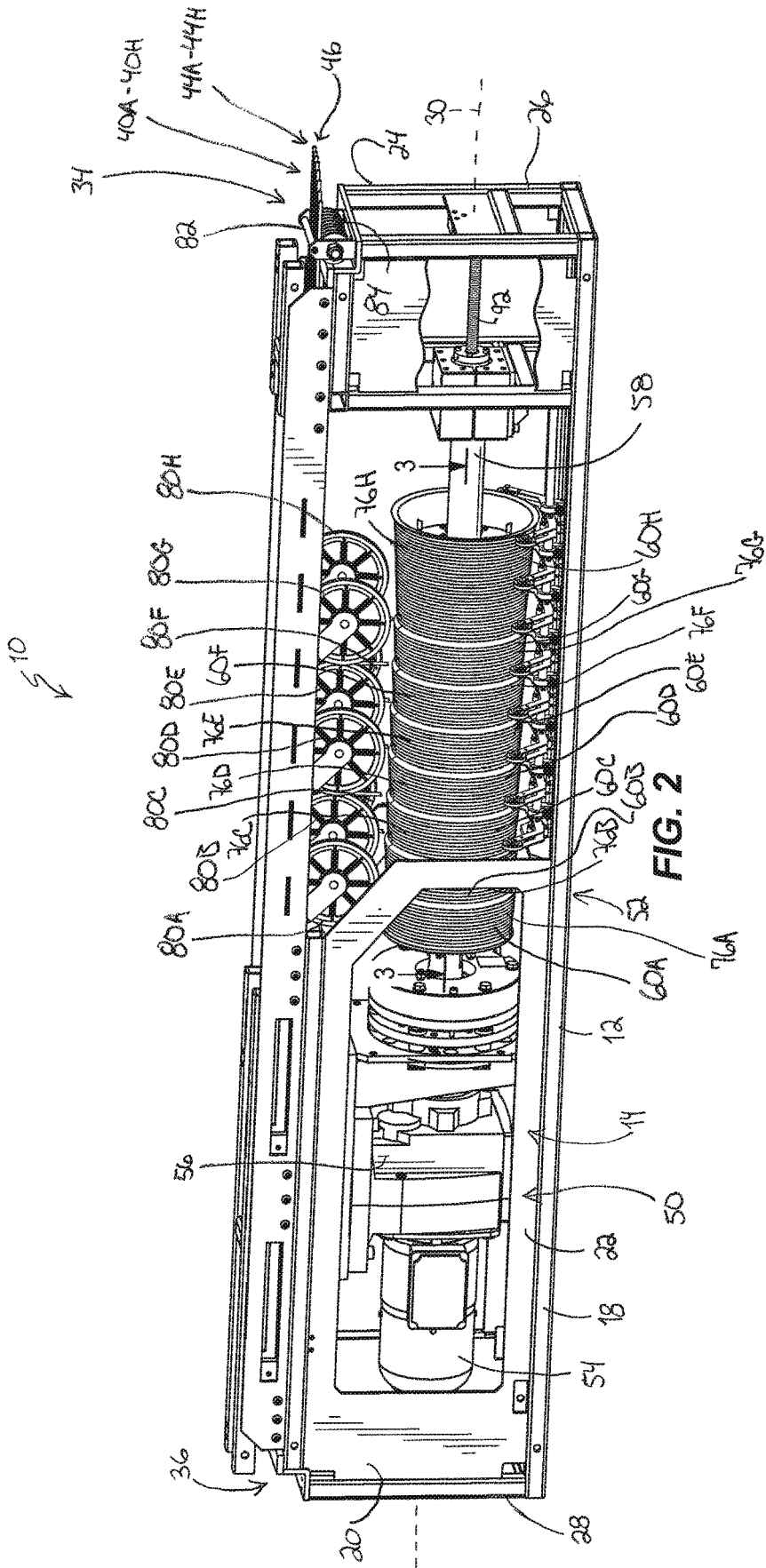

FIG. 1



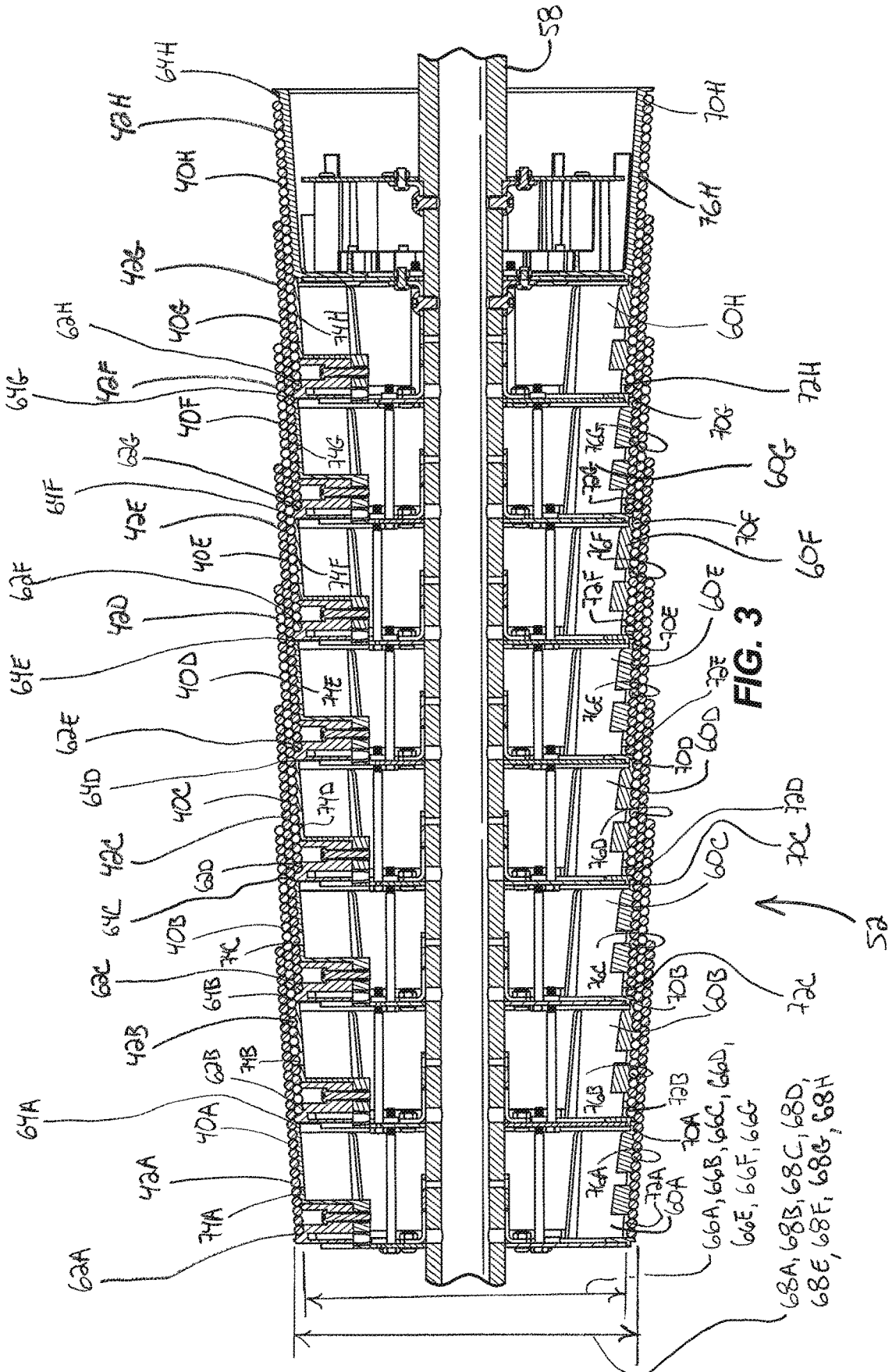
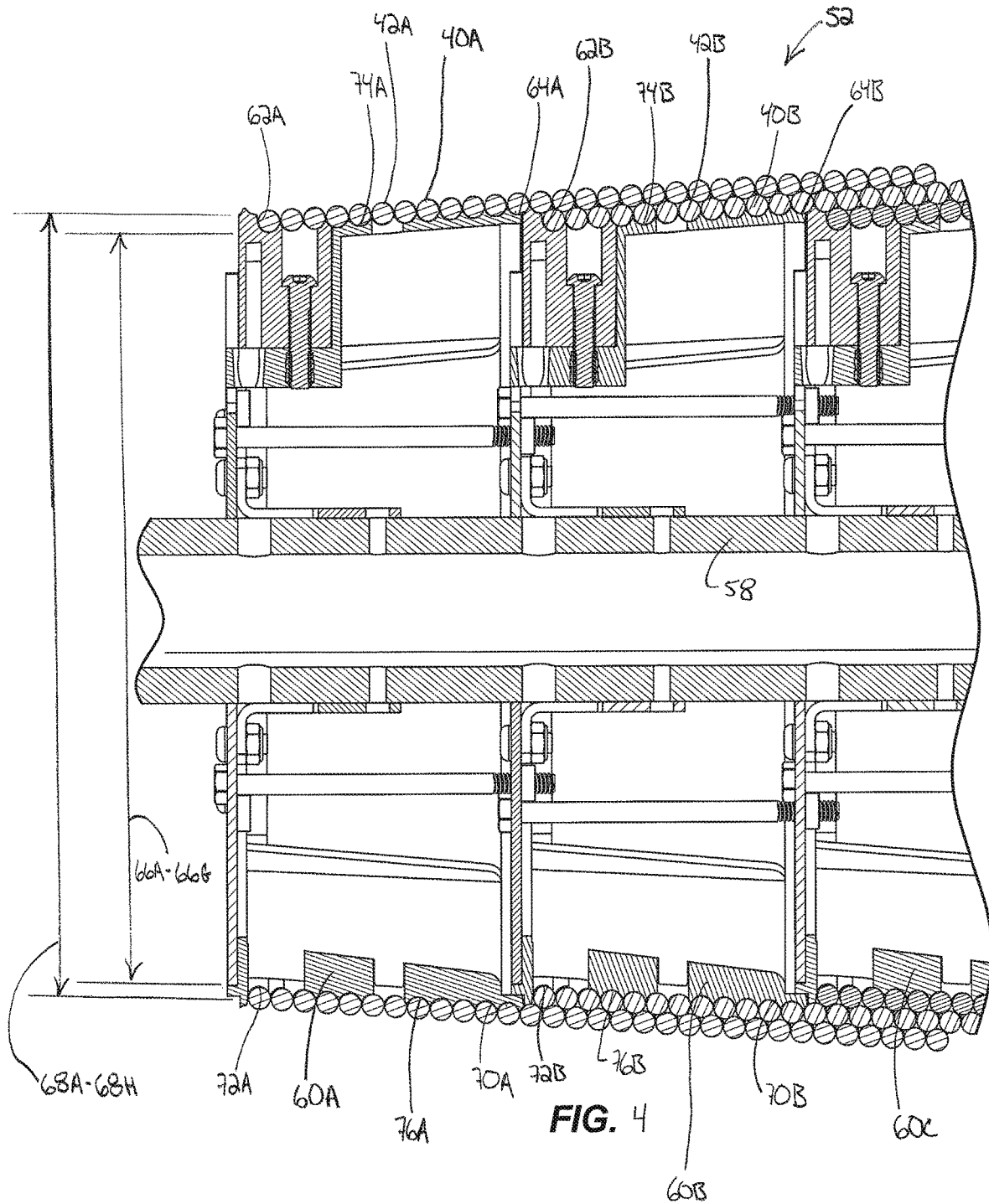

FIG. 3

68A, 68B, 68C, 68D,
68E, 68F, 68G, 68H



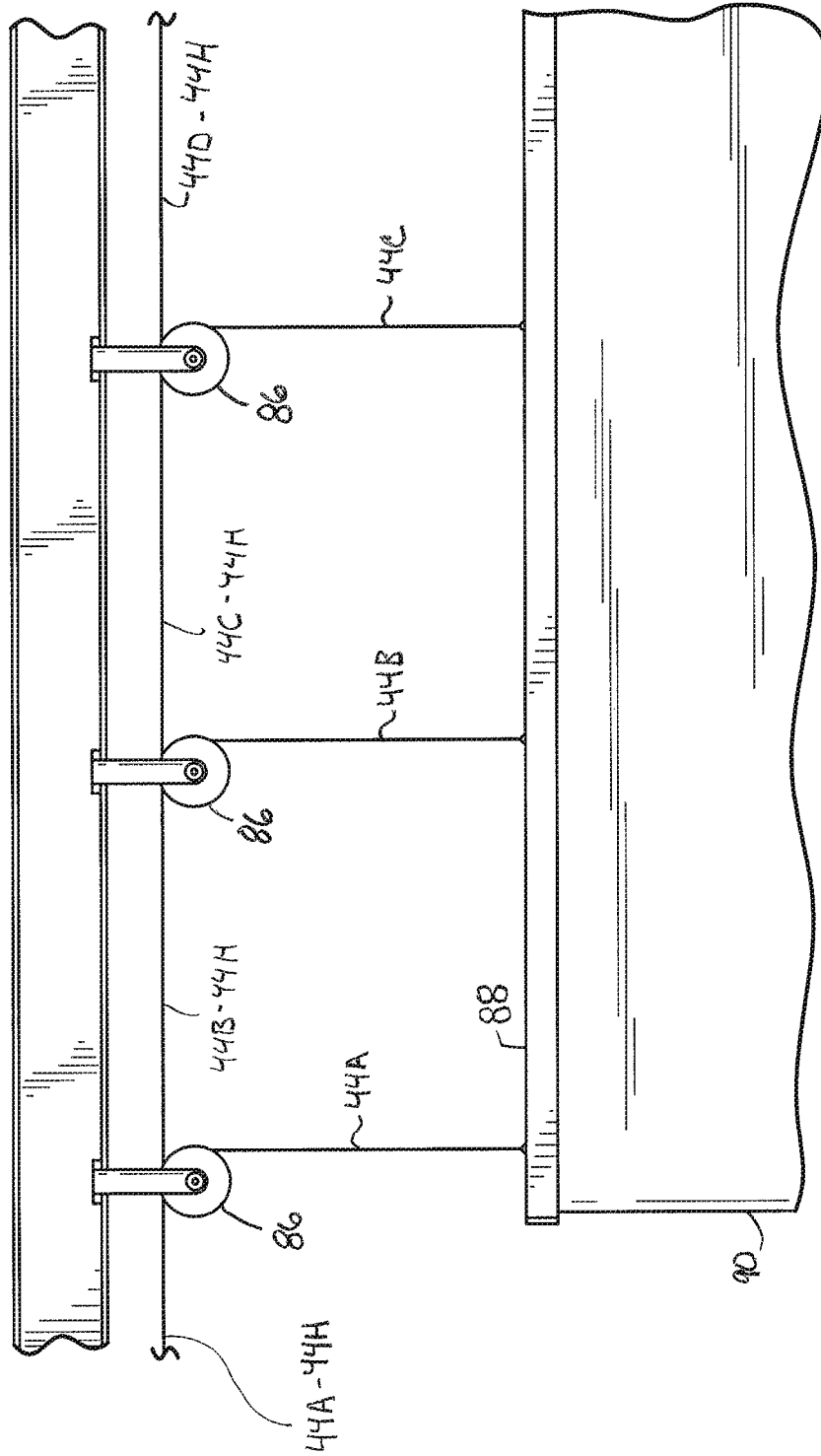

FIG. 5

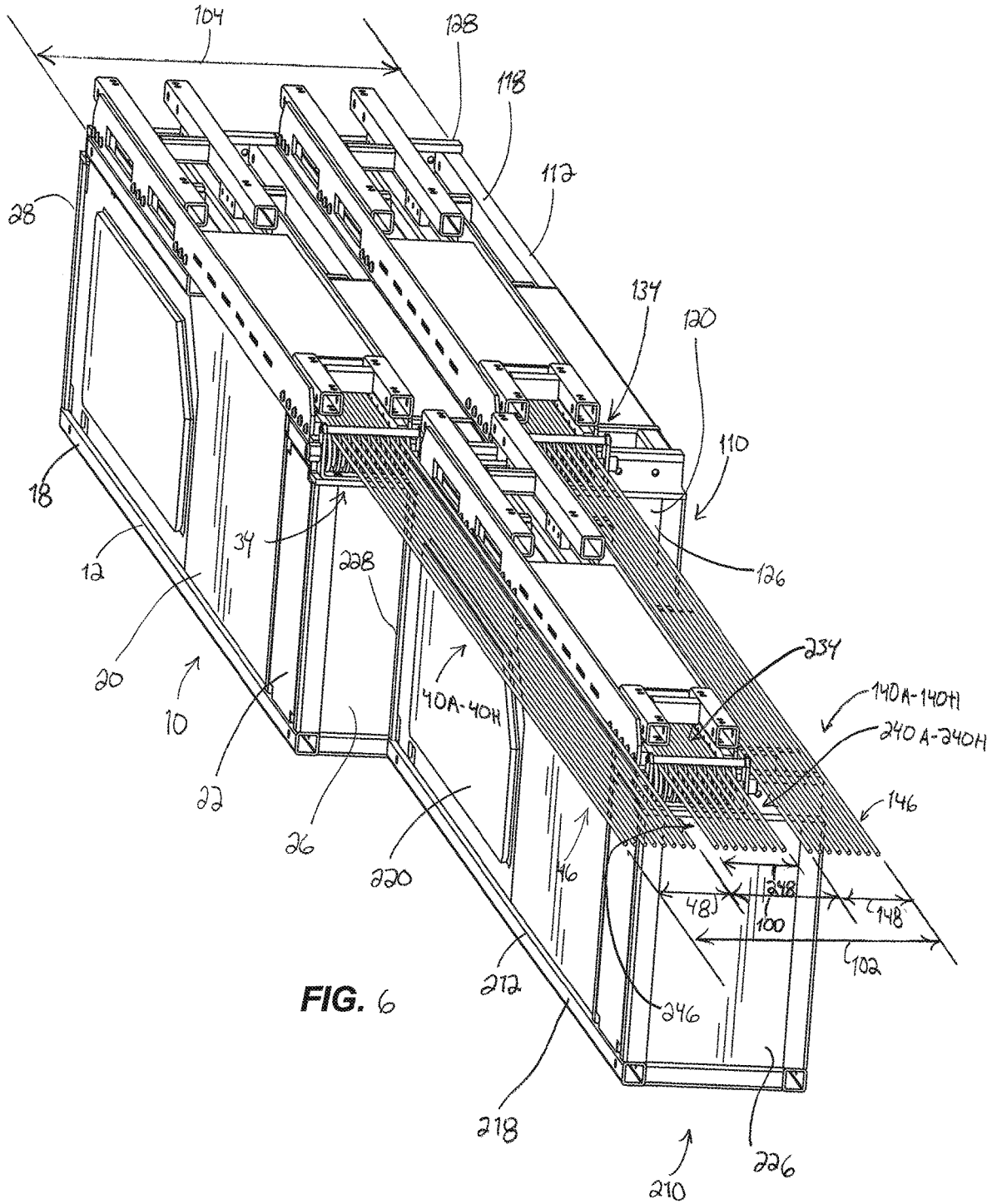

FIG. 6

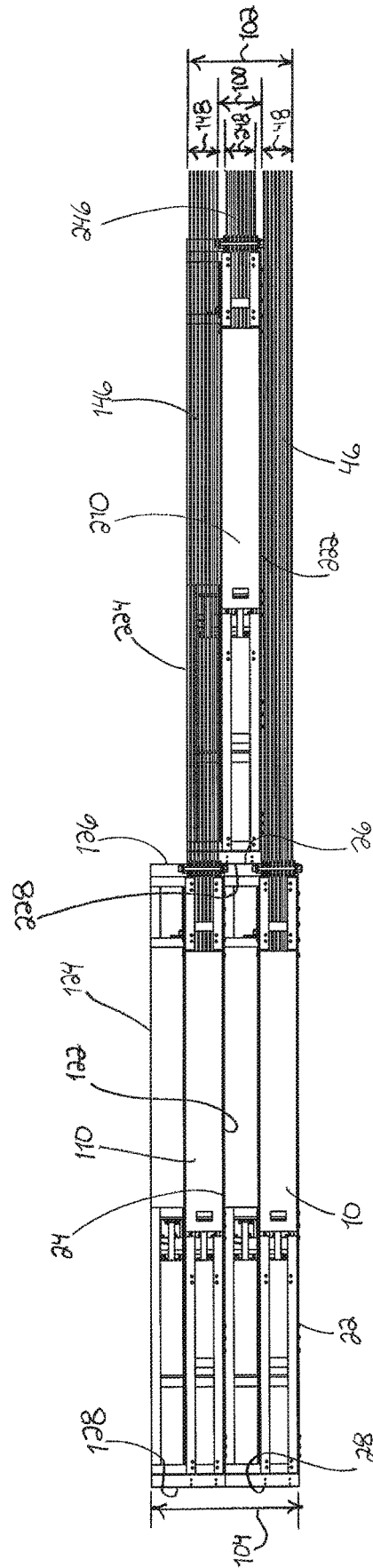

FIG. 7

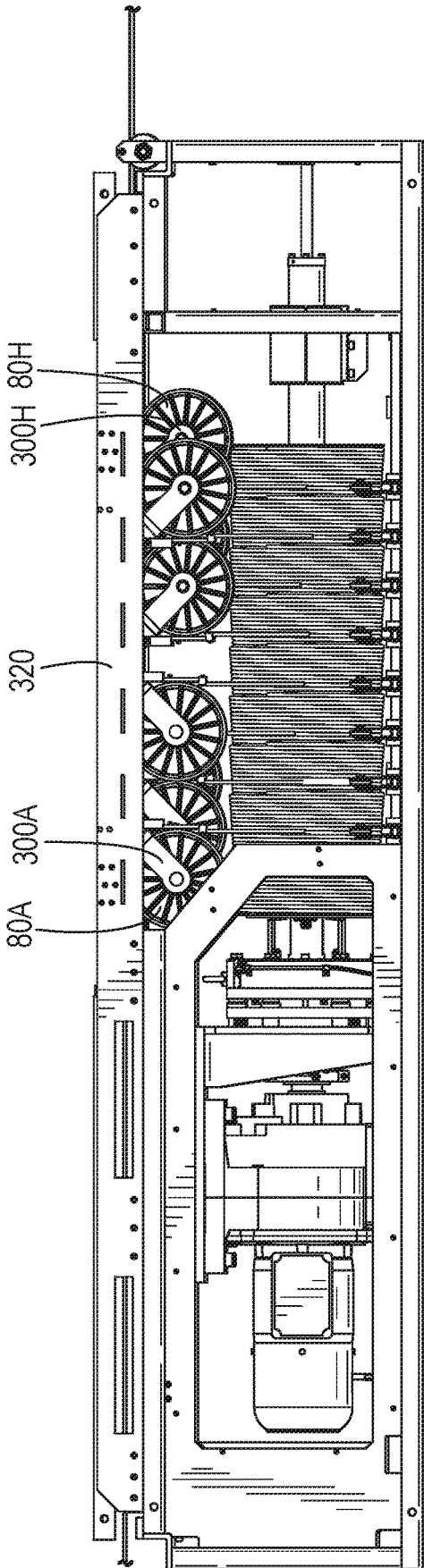

FIG. 8

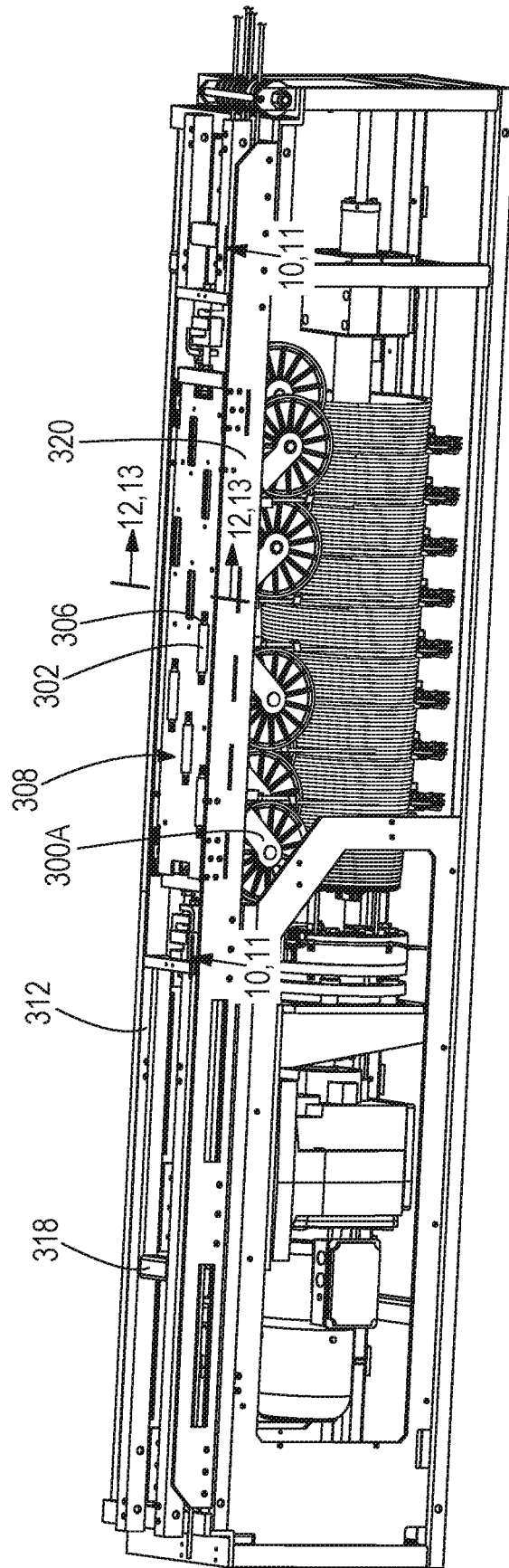

FIG. 9

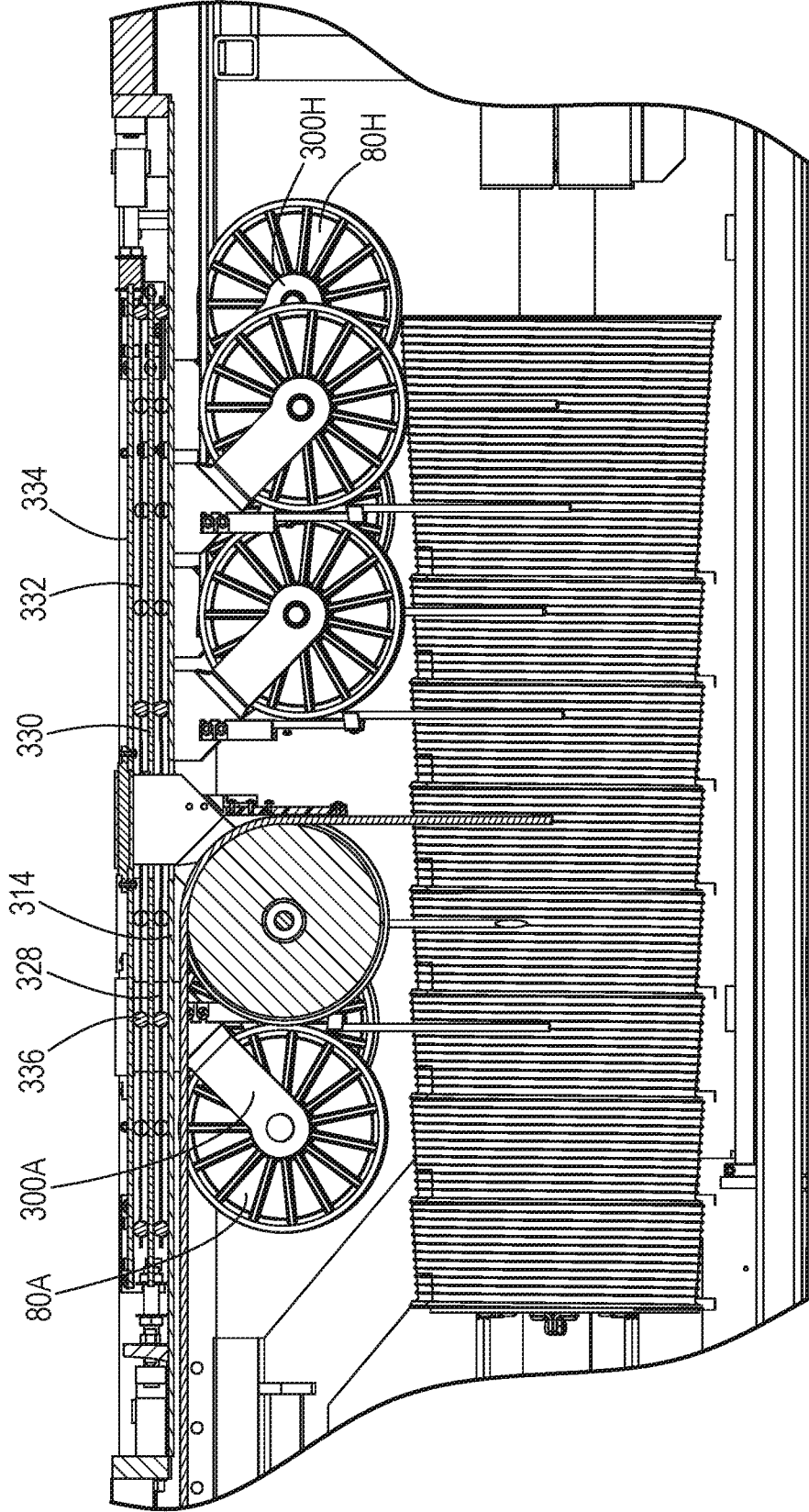

FIG. 10

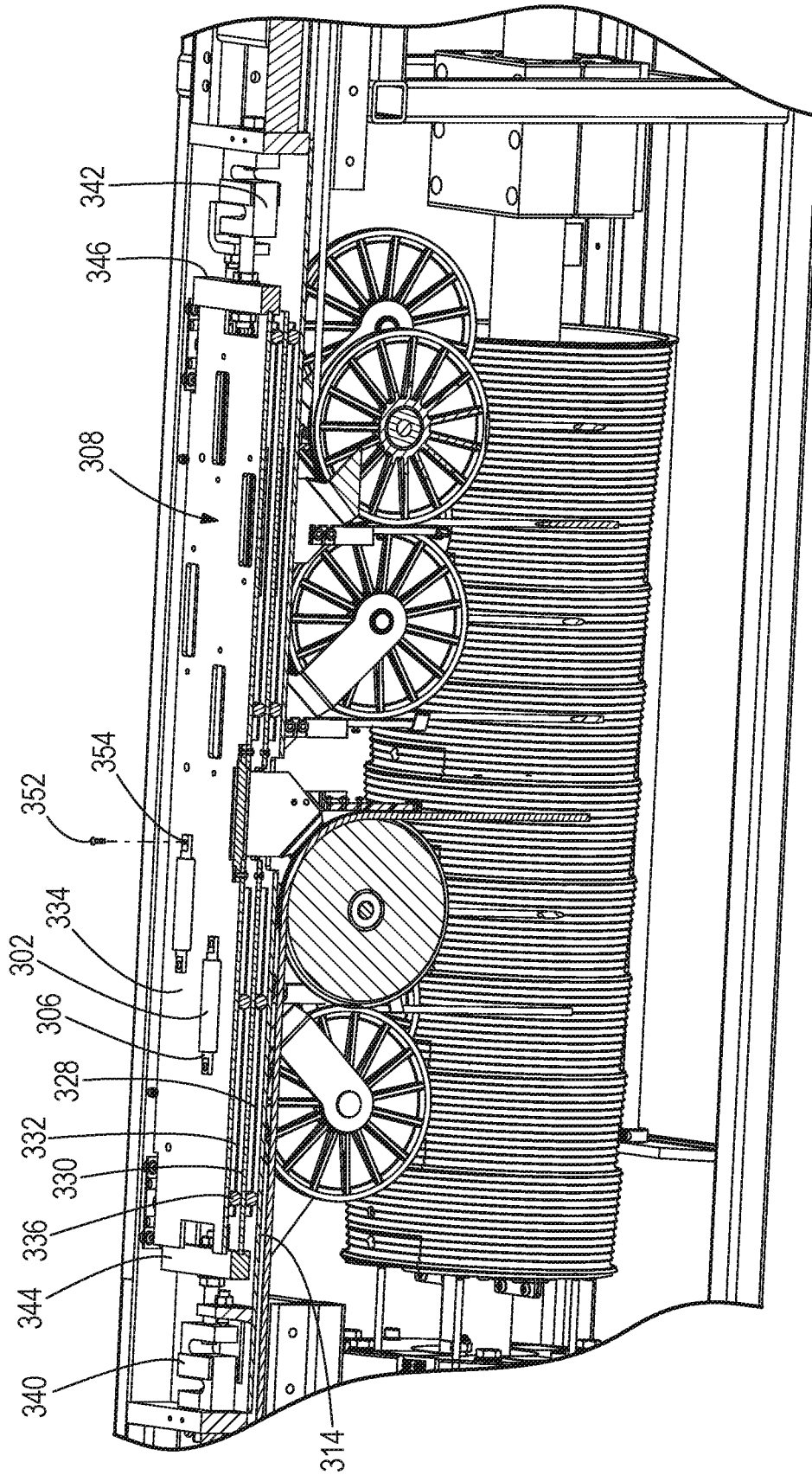

FIG. 11

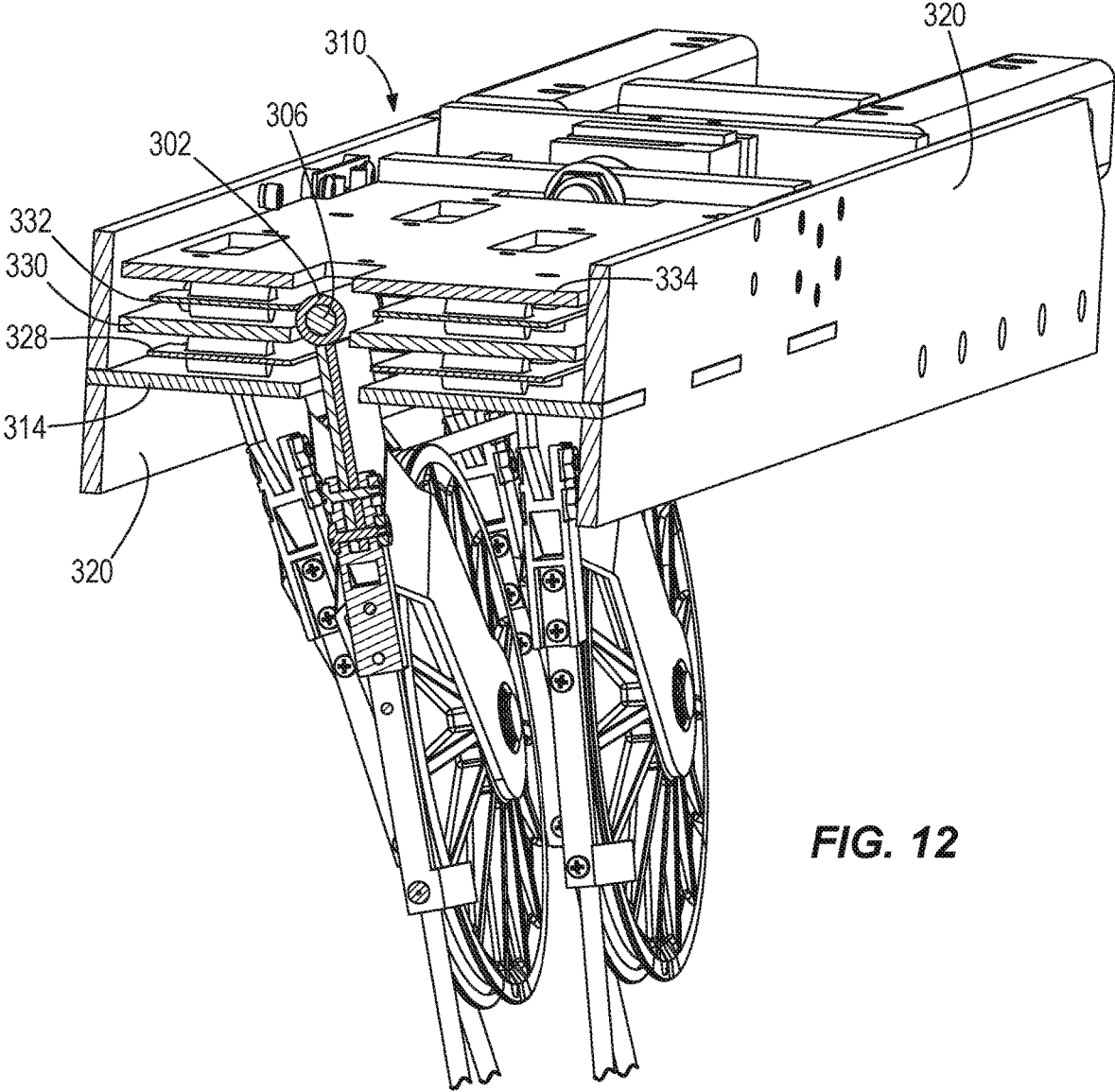

FIG. 12

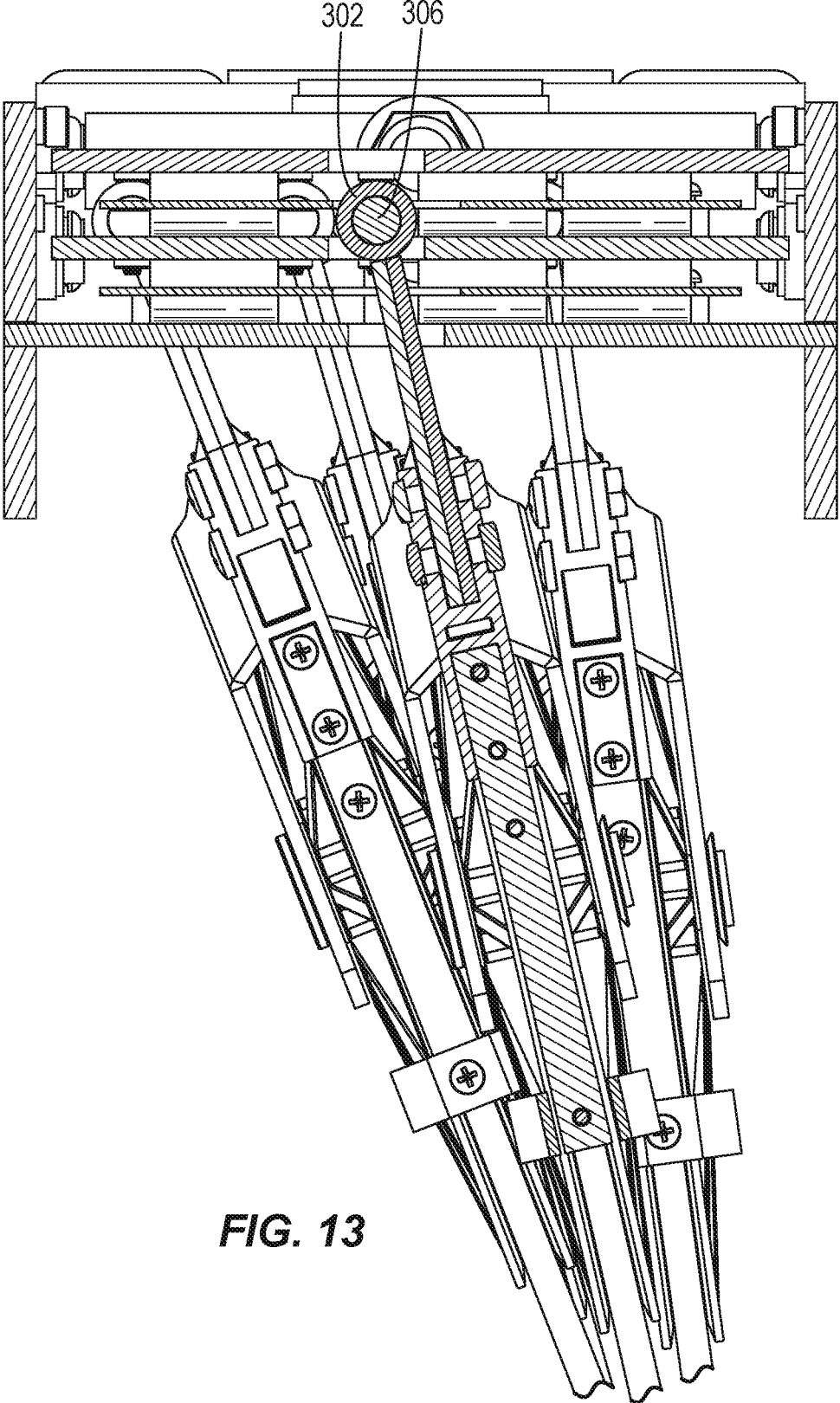

FIG. 13

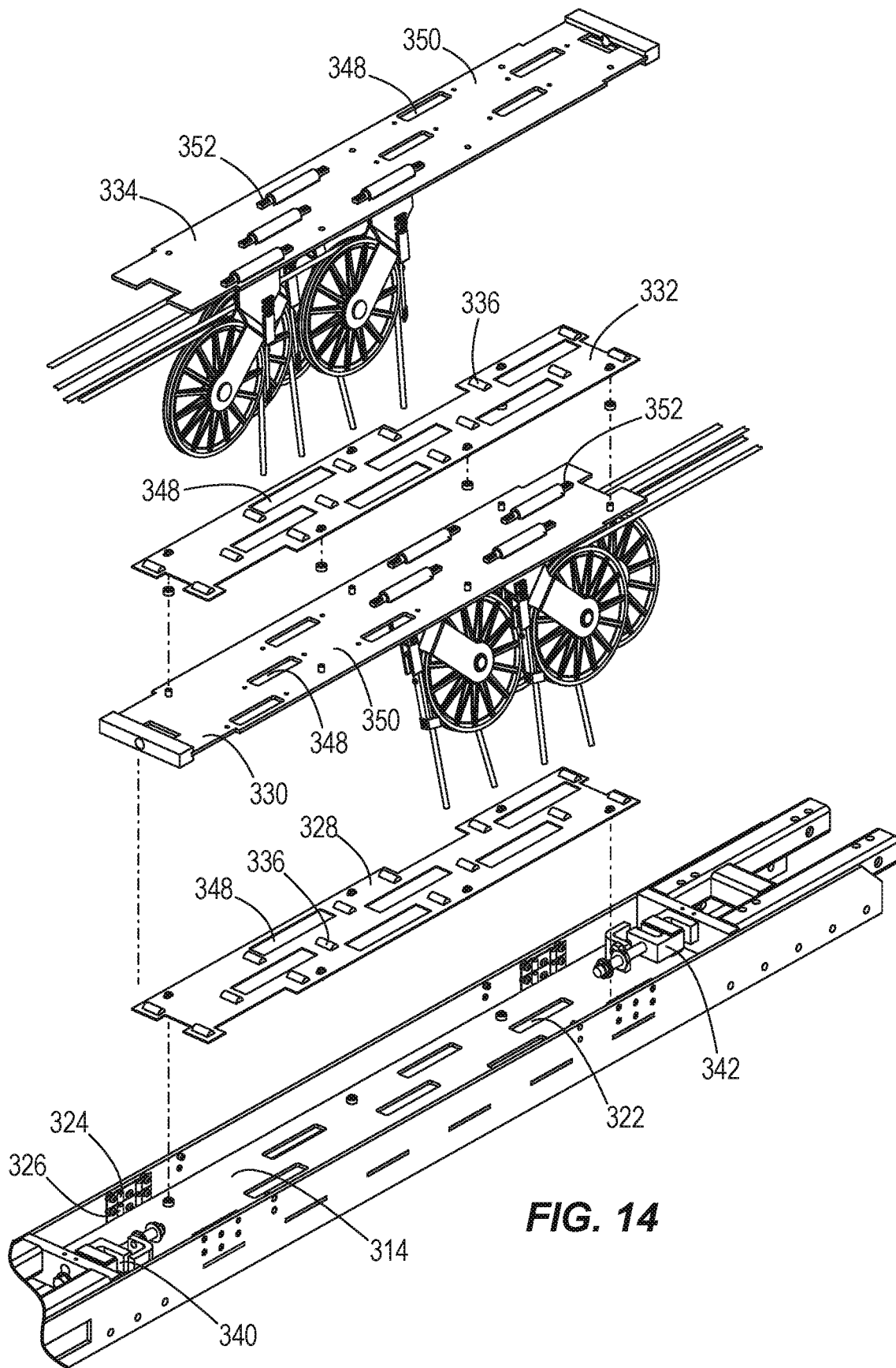
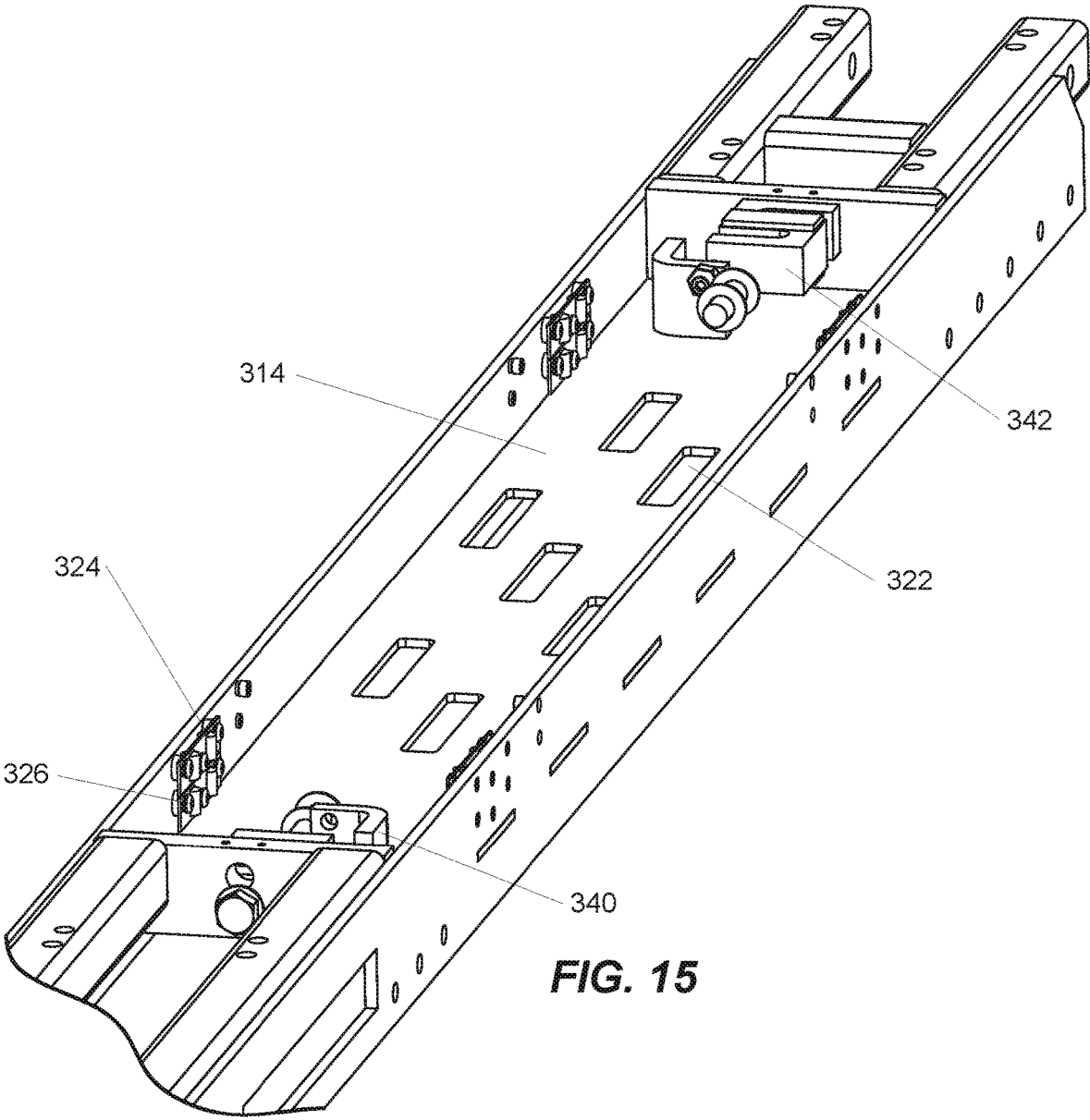

FIG. 14



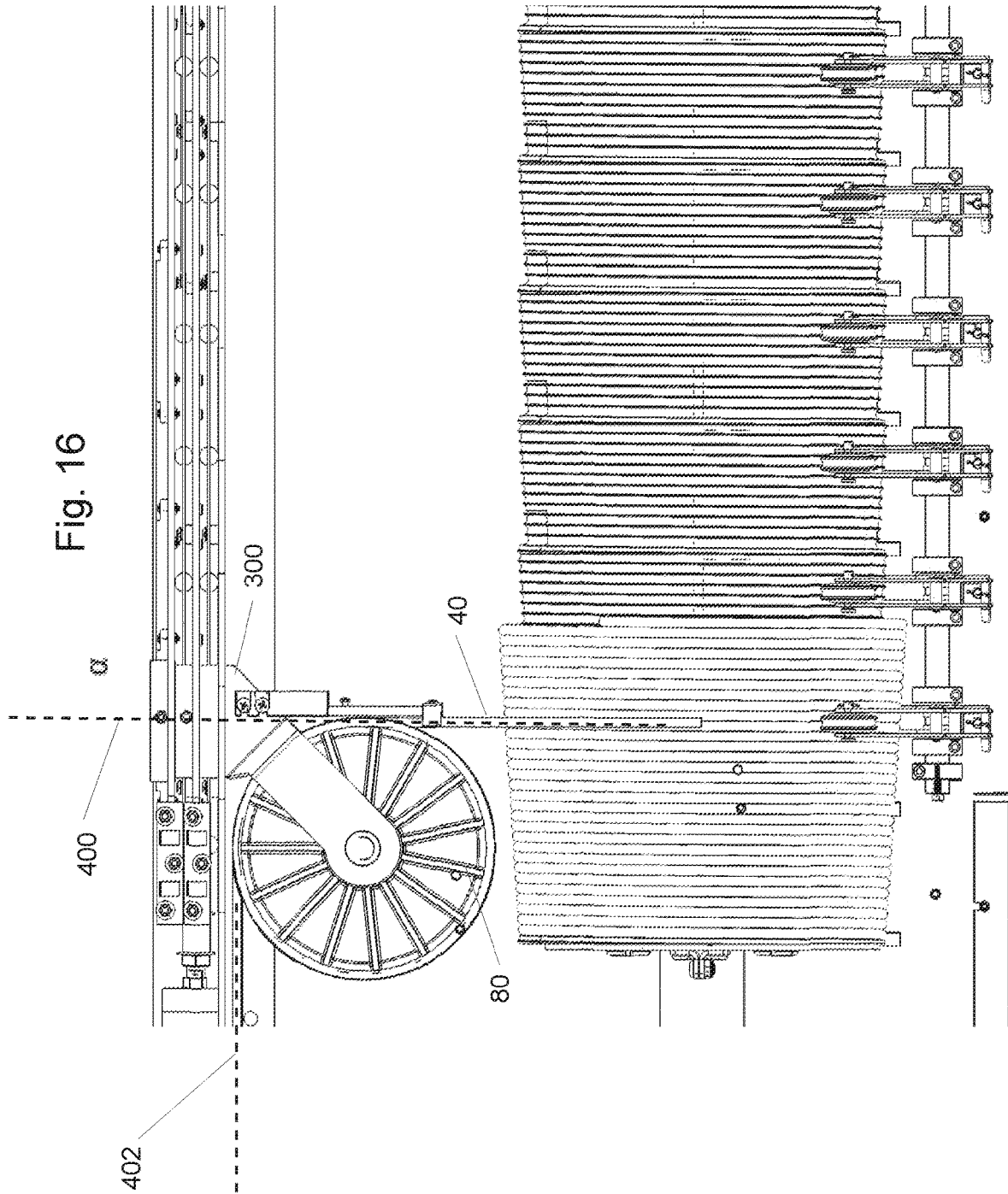
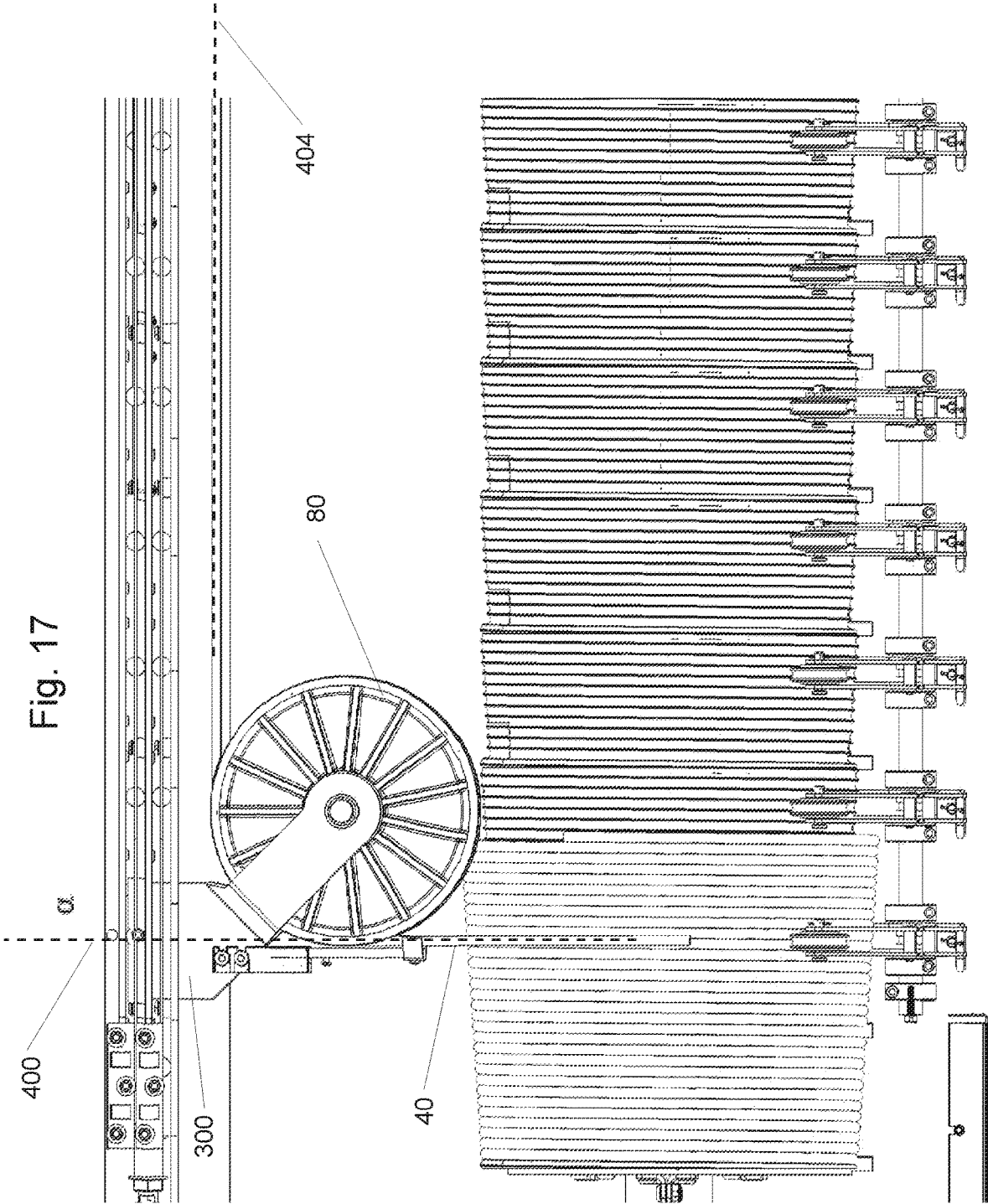

Fig. 17



1

LIFT ASSEMBLY WITH LOAD CELLS**CROSS-REFERENCE TO RELATED APPLICATIONS**

This application is a Continuation of U.S. patent application Ser. No. 15/033,804, filed May 2, 2016, which is national stage filing under 35 U.S.C. § 371 of International Application No. PCT/US2014/066573, filed Nov. 20, 2014, which claims priority to U.S. Provisional Patent Application No. 61/907,786, filed Nov. 22, 2013, the entire contents of which are incorporated by reference herein.

BACKGROUND

The present invention relates generally to lift assemblies, such as those used to raise and lower scenery, props, and lighting on a stage.

Performance venues such as theaters, arenas, concert halls, auditoriums, schools, clubs, convention centers, and television studios can employ battens or trusses to suspend, elevate, and/or lower lighting, scenery, draperies, and other equipment that can be moved relative to a stage or floor. These battens are often raised or lowered by lift systems.

Conventional lift systems commonly include an overhead pulley, or loft block, supported by an overhead building support. Ropes or cables extend from the batten and through the loft blocks to a drive mechanism that facilitates movement of the cables. Such drive mechanisms often include a motor-driven drum that winds and unwinds the cables.

In order to insure that the lift system does not exceed capacity, some lift systems include means for measuring the load on the system. In the event that the load is exceeded, the motor can be deactivated or a warning can be generated.

SUMMARY

The present invention provides a lift assembly comprising a base, a drive mechanism, a flexible drive element driven by the drive mechanism and extending from the drive mechanism along a fleet axis, and a sheave directing the drive element from the fleet axis to an output axis different than the fleet axis. The sheave is coupled to the base at a first sheave mount aligned with the fleet axis. In one embodiment, the assembly further includes a second sheave mount aligned with the fleet axis, the second sheave mount being configured to be coupled to the sheave to thereby allow the sheave to be de-coupled from the first sheave mount and coupled to the second sheave mount. The second sheave mount is positioned such that coupling of the sheave to the second sheave mount results in substantially no change in a fleet angle of the fleet axis. Preferably, the sheave is positioned on a first side of the fleet axis when coupled to the first sheave mount, and the sheave is positioned on a second side of the fleet axis when coupled to the second sheave mount, the second side being substantially opposite the first side.

In one embodiment, the fleet axis substantially bisects the first and second sheave mounts. Preferably, the first and second sheave mounts are positioned on first and second sheave plates, respectively. For example, the first sheave plate can be positioned at least partially directly below the second sheave plate.

Other aspects of the invention will become apparent by consideration of the detailed description and accompanying drawings.

BRIEF DESCRIPTION OF THE DRAWINGS

FIG. 1 is a perspective view of a lift assembly according to one embodiment of the invention.

2

FIG. 2 is an alternative perspective view of the lift assembly of FIG. 1 with side panels of the lift assembly removed.

FIG. 3 is a cross-sectional view of a portion of the lift assembly of FIG. 1 taken along lines 3-3 of FIG. 2.

FIG. 4 is an enlarged view of a portion of FIG. 3.

FIG. 5 illustrates one application of the lift assembly of FIG. 1.

FIG. 6 is a perspective view of multiple lift assemblies of FIG. 1 in a nested configuration according to another embodiment of the invention.

FIG. 7 is a top view of the nested lift assemblies of FIG. 4.

FIG. 8 is a side view of a second embodiment of a lift assembly embodying aspects of the present invention with a side panel removed.

FIG. 9 is a perspective view of the lift assembly of FIG. 8.

FIG. 10 is an enlarged side view of a portion of the lift assembly of FIG. 8.

FIG. 11 is an enlarged perspective view of the portion of the lift assembly of FIG. 10.

FIG. 12 is a perspective view taken in section along line 12-12 in FIG. 9.

FIG. 13 is an end view of the section view of FIG. 12.

FIG. 14 is an exploded perspective view of the lift assembly of FIG. 8.

FIG. 15 is an enlarged perspective view of a portion of the lift assembly of FIG. 14.

FIG. 16 is a side view of the lift assembly with emphasis on one sheave in a first position.

FIG. 17 is the side view of FIG. 16 with the sheave rotated to a second position.

DETAILED DESCRIPTION

Before any embodiments of the invention are explained in detail, it is to be understood that the invention is not limited in its application to the details of construction and the arrangement of components set forth in the following description or illustrated in the following drawings. The invention is capable of other embodiments and of being practiced or of being carried out in various ways.

FIGS. 1-2 illustrate a lift assembly 10 including a base 12 and a take-up mechanism 14 that is mounted to the base 12. The base 12 includes a frame 18 and side panels 20 that are secured to the frame 18. The frame 18 provides a stable location for mounting the various internal components of the assembly 10, and the panels 20 provide a barrier for inhibiting contamination of and unauthorized access to the internal components and the panels 20 can also be sound deadening panels.

The base 12 further includes a first side 22, a second side 24, a first end 26, and a second end 28 that are defined by the frame 18 and the panels 20. The first side 22 and the second side 24 are parallel and face opposite directions and the first end 26 and the second end 28 are parallel and face opposite directions. The first and second sides 22, 24 extend along the length of the assembly 10 and a longitudinal axis or centerline 30 of the assembly 10 extends midway between the sides 22, 24 and bisecting the ends 26, 28. A length or longitudinal extent of the assembly 10 is the distance from the first end 26 to the second end 28 along the axis 30.

The base 12 further includes a first outlet 34 and a second outlet 36, the purpose of which will be discussed in more detail below. The first outlet 34 is located through the first end 26 of the base 12 and is positioned closer to the first side

22 than to the second side 24. Alternatively stated, the first outlet 34 is offset from the centerline 30 toward the first side 22 of the base 12. The second outlet 36 is located through the second end 28 of the base 12 and is positioned closer to the first side 22 of the base 12 than the second side 24. Similar to the first outlet 34, the second outlet 36 is offset from the centerline 30 toward the first side 22 of the base 12.

Referring to FIGS. 1 and 3, the lift assembly 10 further includes flexible drive elements 40A-40H. Each of the flexible drive elements 40A-40H is essentially the same (the only difference being their respective length), and only one flexible drive element 40A will be described in detail. Like portions of the drive elements 40A-40H have been given the same reference number with the suffix A-H, respectively. The flexible drive element 40A includes a stored portion 42A that is on the take-up mechanism 14 and a free portion 44A that extends from the take-up mechanism 14 through the outlet 34. The free portion 44A that extends through the outlet 34 is closer to the first side 22 of the base 12 than to the second side 24. That is, the free portion 44A is offset from the centerline 30 of the base 12 in a direction toward the first side 22. Together the flexible drive elements 40A-40H extend through the outlet 34 to define a cable path 46 having a cable path width 48 (see FIG. 4). The cable path 46 is offset from the centerline 30 of the base 12 in a direction toward the first side 22. In the illustrated embodiment, the entire cable path 46 (i.e., all of the flexible drive elements 40A-40H) exiting the outlet 34 is located between the first side 22 and the centerline 30. In other embodiments, a portion of the cable path 46 can be on the other side of the centerline 30 (i.e., between the centerline 30 and the second side 24). Also, in the illustrated embodiment, all of the flexible drive elements 40A-40H in the cable path are flush in a direction perpendicular to the cable path 46, such that the cable path 46 is flat and the flexible drive elements 40A-40H are co-planar. In the illustrated embodiment, the flexible drive elements 40A-40H are cables, such as a twisted wire cables with multiple strands, but in other embodiment, other suitable flexible drive elements may be utilized, such as, chains, ropes, and the like.

As illustrated in FIG. 5, in one application of the lift assembly 10, the free portions 44A-44H of the flexible drive elements 40A-40H are routed to loft blocks 86 that change the direction of the flexible drive elements 40A-40H and then routed to a batten 88 or the like to raise and lower an article 90 such as scenery, props, and lighting on a stage.

Referring to FIG. 2, the take-up mechanism 14 includes a drive mechanism 50 and a drum assembly 52. The drive mechanism 50 includes an electric motor 54, a transmission 56, and a drive shaft 58. The transmission connects the motor 54 and the drive shaft 58 such that operation of the motor 54 rotates the drive shaft 58 in the clockwise and counterclockwise directions. The drum assembly 52 is coupled to the drive shaft 58, such that rotation of the drive shaft 58 by the motor 54 rotates the drum assembly 52 in the clockwise and counterclockwise directions. In the illustrated embodiment, the drum 52 and the drive shaft 58 move axially along the longitudinal axis 30 of the base 12, the purpose of which will be discussed in more detail below.

Referring to FIGS. 3 and 4, the drum assembly 52 includes drum segments 60A-60H. The drum segments 60A-60H correspond to the flexible drive elements 40A-40H. That is, the flexible drive element 40A winds around drum segment 60A, the flexible drive element 40B winds around drum segment 60B, etc. The drum segments 60A-60H are substantially the same and like components have been given like reference numbers with the suffix A-H,

which corresponds to the drum segments 60A-60H. The drum segment 60A includes a first end 62A and a second end 64A. The first end 62A has a diameter 66A and the second end 64A has a diameter 68A that is larger than the diameter 66A. The diameter of the drum segment 60A constantly increases from the first end 62A to the second end 64A. Therefore, a large diameter portion 70A of the drum segment 60A is located adjacent the second end 64A, a small diameter portion 72A is located adjacent the first end 62A, and a tapered portion 74A is located between the small diameter portion 72A and the large diameter portion 70A.

The drum segments 60A-60H are coupled to the drive shaft 58 as best seen in FIG. 3. The first end 62B of the second drum segment 60B having the small diameter 66B abuts the second end 64A of the first drum segment 60A having the large diameter 68A. Likewise, the first end 62C of the third drum segment 60C having the small diameter 66B abuts the second end 64B of the second drum segment 60B having the large diameter 68B. The remainder of the drum segments 60D-60H are similarly arranged along the drive shaft 58.

The drum segments 60A-60H all include grooves 76A-76H, respectively, that extend circumferentially around the drum segments 60A-60H. The grooves 76A-76H receive the respective flexible drive elements 40A-40H to facilitate winding the flexible drive elements 40A-40H around the drum assembly 52.

Referring to FIG. 2, the lift assembly further includes internal sheaves 80A-80H. The internal sheave 80A corresponds to the drum segment 60A and the flexible drive element 40A, the internal sheave 80B corresponds to the drum segment 60B and the flexible drive element 40B, etc. The sheaves 80A-80H direct the corresponding flexible drive element 40A-40H from the corresponding drum segment 60A-60H to the outlet 34. A head block 82 is located adjacent the outlet 34. The head block 82 includes a plurality of rollers 84 that guide the flexible drive elements 40A-40H. In the illustrated embodiment, the internal sheaves 80A-80H can be configured to route the flexible drive elements 80A-80H through the first outlet 34 and the second outlet 36. When any of the flexible drive elements 80A-80H are routed through the second outlet 36 a second head block, similar to head block 82, would be located adjacent the second outlet 36.

With continued reference to FIG. 2, the illustrated lift assembly 10 includes a threaded rod 92 located at an end of the shaft 58. The rod 92 is fixed relative to the frame 18. The shaft 58 is generally hollow and the threaded rod 92 is received in a threaded recess of the shaft 58. As the shaft 58 rotates relative to the rod 92 (which is fixed relative to the frame 18) the shaft 58 and drum assembly 52 (which is fixed relative to the shaft 58) move relative to the internal sheaves 80A-80H along the longitudinal axis 30 to facilitate winding and unwinding the flexible drive elements 40A-40H around the drum assembly 52.

In operation, the motor 54 rotates the drive shaft 58 to wind and unwind the flexible drive elements 40A-40H around the drum assembly 52 to raise and lower the free portions 44A-44H of the flexible drive elements 40A-40H, which raises and lowers an article, such as scenery, props, lighting, and the like that are attached to the free portions 44A-44H. As best seen in FIG. 3, when raising the article, the flexible drive elements 40A-40H wrap around the corresponding drum segment 60A-60H in the corresponding grooves 76A-76H. The first flexible drive element 40A starts wrapping around the segment 60A in the grooves 76A in the small diameter portion 72A of the segment 60A. Meanwhile,

the second flexible drive element **40B** starts wrapping around the drum segment **60B** in the grooves **76B** in the small diameter portion **72B** of the drum segment **60B**. The additional flexible drive elements **40C-40H** likewise wrap around the corresponding drum segments **60C-60H**.

The flexible drive element **40B** is wrapped onto the small diameter portion **72B** of the drum segment **60B** to define an outer profile or outer diameter that is substantially flush with the large diameter portion **70A** of the drum segment **60A**. As the flexible drive element **40A** continues to wind onto the drum segment **60A**, the additional stored portion **42A** moves in a direction toward the drum segment **60B** because the drum assembly **52** moves relative to the frame **18** along the longitudinal axis **30**. Eventually, the flexible drive element **40A** wraps around the drum segment **60A** until it reaches the second end **64A** of the drum segment **60A**, and as the flexible drive element **40A** continues to wind around the drum assembly **52**, the flexible drive element **40A** overlaps onto the outer profile created by the flexible drive element **40B**. As discussed above, the outer profile of the drive element **40B** is flush with the second end **64A** of the drum segment **60A**, and therefore the drive element **40A** smoothly transitions from wrapping around the segment **60A** and onto the segment **60B**. As illustrated in FIG. 3, the other flexible drive elements **40B-40G** similarly overlap onto the adjacent drum segment **60B-60G**. Because segment **60H** is the final drum segment there is no adjacent segment for drive element **40H** to wrap onto and around. Therefore, drum segment **60H** is longer and has a longer tapered portion **74H** than the other drum segments **60A-60G**.

As illustrated in FIGS. 6 and 7, multiple lift assemblies **10**, **110**, and **210** can be mounted adjacent to each other and together the lift assemblies **10**, **110**, **210** can be mounted to a structure, such as a ceiling, a floor, walls, or other suitably stable component. Each of the illustrated lift assemblies **10**, **110**, and **210** is structurally identical to the other lift assemblies **10**, **110**, and **210** and identical to the lift assembly **10** described above with regard to FIGS. 1-3 and therefore like components have been given like reference numbers plus 100. Each lift assembly **10**, **110**, and **210** has its own position or orientation, as described below in more detail.

With continued reference to FIGS. 6 and 7, the second side **24** of the first lift assembly **10** is positioned adjacent the first side **122** of the second lift assembly **110**. In the illustrated embodiment, the second side **24** of the lift assembly **10** abuts the first side **122** of the lift assembly **110**. Also, the ends **26**, **126** and **28**, **128** are aligned and flush as illustrated. Therefore, the cable path **46** and the cable path **146** extend in the same direction and are parallel. As illustrated in FIGS. 6 and 7, the cable path **46** exiting the base **12** of the first lift assembly **10** is spaced a distance **100** from the cable path **146** exiting the base **112** of the second lift assembly **110**.

The second end **228** of the base **212** of the third lift assembly **210** abuts the first end **26** of the first lift assembly **10** and the first end **126** of the second lift assembly **110** to define a pyramid arrangement with the third lift assembly **210** forming a peak of the pyramid. The third lift assembly **210** is positioned so that the cable path **246** is between in the cable paths **46**, **146** and located in the space **100**. The cable path **246** extends in the same direction as the cable paths **46**, **146** and parallel to the paths **46**, **146** and the cable paths **46**, **146**, **246** are co-planar. Together the cable paths **46**, **146**, **246** define a total cable path width **102**. In the illustrated embodiment that includes three lift assemblies **10**, **110**, **210**, the total cable path width **102** is only about 3.6 times greater than the width **48** of a single cable path **48**, **148**, **248**. In other

embodiments, the total cable path width is between about 3.3 to 3.9 times greater than the width of a single cable path. In yet other embodiments, the total cable path width is between about 3.1 to 4.1 times greater than the width of a single cable path.

The base **12** of the first lift assembly **10** and the base **112** of the second lift assembly **110** are side-by-side to define a total width **104** (FIG. 7) of the group of lift assemblies **10**, **110**, and **210**. The total cable path width **102** is less than the width **104** of the group of lift assemblies **10**, **110**, **210**. In some embodiments, the total cable path width **102** is less than 80 percent of the width **104**, and in yet other embodiments, the total cable path width **102** is less than 95 percent of the width **104**.

The first, second, and third lift assemblies **10**, **110**, **210** can be coupled using any suitable fastener or method such as bolts, welding, and the like. Also, although the illustrated third lift assembly **210** abuts both ends **26**, **126** of the lift assemblies **10**, **110**, respectively, in other embodiments, the end **226** of the third lift assembly **210** may abut only one of the ends **26**, **126**.

The nested arrangement of the lift assemblies **10**, **110**, **210**, described above, reduces the total cable path width **102** (compared to positioning the three lift assemblies in a side-by-side orientation). Reducing the total cable path width **102** is desirable because it reduces the distance required between articles lifted by the lift assemblies **10**, **110**, **210**. Or, if the lift assemblies **10**, **110**, **210** are lifting the same article, the distance between all the flexible drive elements **40**, **140**, **240** is reduced, which reduces the horizontal spacing required between any lift blocks that redirect the flexible drive elements **40**, **140**, **240** down to the article being raised and lowered.

Referring to FIGS. 8-15, the sheaves **80A-H** are supported by sheave brackets **300A-H**, respectively. Each sheave bracket **300** includes a sheave pivot **302** having an opening through which a sheave pin **306** can be positioned to allow the sheave bracket **300** to rotate relative to the sheave pin **306**. The sheave pins **306** are each secured to a load plate assembly **308**, as described below in more detail.

The load plate assembly **308** rests in a pocket **310** formed in an upper frame **312** that is part of the frame **18**. The upper frame **312** includes a bottom plate **314**, two longitudinal members **316**, two cross members **318**, and two side rails **320** secured to opposing outer surfaces of the longitudinal members **316**. The bottom plate **314** includes openings **322** through which the sheave brackets **300** are positioned. The side rails **320** include upper and lower side bearings **324,326** (e.g., roller bearings, FIGS. 14-15), the function of which are described below.

The load plate assembly **308** includes a lower bearing plate **328** positioned on the bottom plate **314**, a lower sheave plate **330** positioned on the lower bearing plate **328**, an upper bearing plate **332** positioned on the lower sheave plate **330**, and an upper sheave plate **334** positioned on the upper bearing plate **332**. In this manner, it can be seen that the lower sheave plate **328** is positioned directly below the upper sheave plate **332**. The upper and lower bearing plates **332,328** each includes roller bearings **336** positioned under each plate to facilitate longitudinal movement of the upper and lower sheave plates **334,330** relative to the upper frame **312**. The upper and lower side bearings **324,326** reduce friction between the upper and lower sheave plates **334,330** and the upper frame **312**.

The load plate assembly **308** further includes upper and lower load cells **340,342** and upper and lower end caps **344,346** sandwiched between the upper and lower sheave

plates **334,330** and the upper and lower load cells **340,342**, respectively. In this manner, the upper load cell **340** senses a horizontal load to the right (in the Figures) on the upper sheave plate **334**, and the lower load cell **342** senses a horizontal load to the left (in the Figures) on the lower sheave plate **330**.

Each of the upper and lower bearing plates **332,328** and upper and lower sheave plates **334,330** includes openings **348** through which the upper portion of corresponding sheave brackets **300** can be inserted. For example, when a sheave bracket **300** is secured to the upper shave plate **334**, an upper end of the sheave bracket **300** will protrude through the opening **348** in the upper shave plate (see, e.g., FIGS. **14** and **16**) and a middle portion of the shave bracket **300** will be positioned in the aligned openings **340** of the upper and lower bearing plates **332,328** and the lower sheave plate **330**.

Adjacent each opening **348** in the upper and lower sheave plates **334,330** there is provided a sheave mount (e.g., threaded holes **350** in the sheave plate **330,334** spaced from the corresponding opening **348**) that facilitates the securing of one of the sheave pins **306**. In the illustrated embodiment, the sheave mount further includes bolts **352** inserted through orifices **354** in the ends of each sheave pin **306** and threaded into the corresponding threaded holes **350** in the corresponding sheave plate **334,330** to secure the sheave brackets **300** to one of the sheave plates.

Each sheave bracket **300** can be secured to either the upper sheave plate **334** or the lower sheave plate **330**, depending on which direction the corresponding cable is directed. In the illustrated embodiment, four sheaves are mounted to each of the upper and lower sheave plates **334,330**. In particular, sheaves **80E-H** that direct cables **40E-H** to the right are mounted to the upper sheave plate **334**, and sheaves **80A-D** that direct cables **40A-D** to the left are mounted to the lower sheave plate **330**. Even though each sheave plate **334,330** is only supporting four sheave brackets **300**, each of the illustrated sheave plates **334,330** includes eight sheave mounts (threaded holes **350** in the sheave plates **334, 330**) that are aligned vertically with the eight sheave mounts of the other sheave plate **334,330**. In this regard, each of the sheave brackets **300** can be mounted to either the upper sheave plate **334** or the lower sheave plate **330**. When switching a particular sheave bracket **300** from one sheave plate to the other, the sheave bracket **300** is rotated 180 degrees about a vertical axis so that the corresponding sheave **80** is positioned to direct the corresponding cable **40** in the opposite direction.

Referring to FIGS. **16-17**, the mounting of each sheave **80** is substantially symmetrical relative to a near edge of the sheave **80**. In other words, rotating a sheave bracket **300** 180 degrees (compare FIG. **16** to FIG. **17**) in order to facilitate mounting the sheave **80** to the other sheave plate does not substantially change the position of the corresponding cable **40** extending from the sheave **80** to the corresponding drum segment (not visible in FIGS. **16-17** because the corresponding drum segment is covered with the cable **40**). In other words, when the sheave **80** is mounted on the upper sheave plate **334**, it is in a first orientation (FIG. **16**) in which the sheave **80** receives the cable **40** from the drum along a fleet axis **400** at a fleet angle α (angle between the fleet axis **400** and the axis of rotation of the drum, when view from the side, as shown in FIG. **16**) and redirects the cable **40** to an output axis **402**. When the sheave **80** is mounted on the lower sheave plate **330**, it is in a second orientation (FIG. **17**) in which the sheave **80** receives the cable **40** substantially along the same fleet axis **400** at substantially the same fleet

angle α and redirects it to a different output axis **404**. When the sheave **80** is moved from the first position to the second position, it is reoriented from one side of the fleet axis **400** to an opposing side of the fleet axis **400**. In both the first and second positions, an edge of the sheave is aligned with the fleet axis **400**. It is noted that the fleet axis **400** substantially bisects the sheave mounts on both the upper and lower sheave plates **334,330**. This feature allows a sheave **80** to direct a cable **40** in either direction without substantially changing the position of the cable **40** relative to the drum segment **60**.

The upper and lower load cells **340,342** are coupled to a processor that determines the horizontal load on each of the upper and lower sheave plates **334,330**. These loads can be summed and/or individually monitored for a given loading arrangement in order to sense deviations from a standard or expected load profile.

Various features and advantages of the invention are set forth in the following claims.

What is claimed is:

1. A lift assembly comprising:

a base;

a drum including a longitudinal axis;

a flexible drive element driven by the drum and extending from the drum along a fleet axis; and

a sheave directing the drive element from the fleet axis to a first output axis different than the fleet axis when the sheave is coupled to the base in a first orientation relative to the base and the sheave is configured to be coupled to the base in a second orientation relative to the base different than the first orientation;

wherein in the first orientation, the sheave directs the drive element from the fleet axis to the first output axis, and

wherein to couple the sheave to the base in the second orientation, the sheave is repositioned relative to the base to an opposing side of the fleet axis to direct the drive element from the fleet axis to a second output axis different than the first output axis.

2. A lift assembly as claimed in claim 1, wherein the sheave is coupled to the base at a first sheave mount in the first orientation aligned with the fleet axis and the lift assembly further comprises a second sheave mount aligned with the fleet axis, the second sheave mount being configured to be coupled to the sheave to thereby allow the sheave to be de-coupled from the first sheave mount and coupled to the second sheave mount to position the sheave in the second orientation, the second sheave mount being positioned such that coupling of the sheave to the second sheave mount results in substantially no change in a fleet angle of the fleet axis.

3. A lift assembly as claimed in claim 2, wherein the first sheave mount is offset relative to a rotational axis of the sheave in a direction that has a component along the longitudinal axis of the drum, wherein the rotational axis of the sheave is positioned on a first side of the fleet axis in the direction along the longitudinal axis when the sheave is coupled to the first sheave mount, and wherein the rotational axis of the sheave is positioned on a second side of the fleet axis in the direction along the longitudinal axis when the sheave is coupled to the second sheave mount.

4. A lift assembly as claimed in claim 2, wherein the fleet axis substantially bisects the first and second sheave mounts in the direction along the longitudinal axis.

5. A lift assembly as claimed in claim 2, wherein the first and second sheave mounts are positioned on first and second

sheave plates, respectively, and wherein the first and second sheave plates are substantially parallel to the first output axis and the second output axis.

6. A lift assembly as claimed in claim 5, wherein the first sheave plate is positioned at least partially directly below the second sheave plate.

7. A lift assembly as claimed in claim 2, wherein the first and second sheave mounts are each movable relative to the base.

8. A lift assembly as claimed in claim 1, wherein the sheave is coupled to a sheave mount by a sheave bracket that positions the sheave with an edge of the sheave aligned with the fleet axis in both the first and second orientations.

9. A lift assembly as claimed in claim 1, wherein the base includes a load plate assembly having a first sheave plate and a second sheave plate, and wherein the sheave is coupled to the first sheave plate in the first orientation, and wherein the sheave is coupled to the second sheave plate in the second orientation.

10. A lift assembly as claimed in claim 1, wherein the sheave is moveable about a rotational axis relative to the base, and wherein the sheave is pivotably coupled to the base about a pivot axis.

11. A lift assembly comprising:

a frame;

a drum supported by the frame; and

a sheave selectively couplable to a portion of the frame in a first orientation and a second orientation, the sheave configured to direct a flexible drive element from the drum along a fleet axis to a first direction when the sheave is in the first orientation, the sheave configured to direct the flexible drive element from the drum along the fleet axis to a second direction different than the first direction when the sheave is in the second orientation; wherein the first orientation is defined by a rotational axis of the sheave being positioned at a first location relative to the portion of the frame and the rotational axis being on a first side of the fleet axis, and wherein the second orientation is defined by the rotational axis of the sheave being positioned at a second location different than the first location relative to the portion of the frame and the rotational axis being on a second side of the fleet axis.

12. A lift assembly as claimed in claim 11, wherein the portion of the frame is a load plate assembly, and wherein the sheave is selectively coupled to a first sheave plate of the load plate assembly when in the first orientation, and wherein the load plate assembly is configured to sense a first horizontal load acting on the first sheave plate.

13. A lift assembly as claimed in claim 12, wherein the load plate assembly includes a second sheave plate, and wherein the sheave is selectively coupled to the second sheave plate when in the second orientation, and wherein the load plate assembly is configured to sense a second horizontal load different than the first horizontal load acting on the second sheave plate.

14. A lift assembly as claimed in claim 13, wherein the first sheave plate is movable relative to the second sheave plate.

15. A lift assembly as claimed in claim 14, wherein the first sheave plate is positioned below the second sheave plate in a direction parallel to the fleet axis.

16. A lift assembly as claimed in claim 13, wherein the sheave is a first sheave of a plurality of sheaves, and wherein the plurality of sheaves is selectively coupled to each of the first sheave plate and the second sheave plate.

17. A lift assembly as claimed in claim 11, wherein the rotational axis of the sheave is positioned on the first side of the fleet axis in a direction that has a component along a longitudinal axis of the drum when the sheave is in the first orientation, and wherein the rotational axis of the sheave is positioned on the second side of the fleet axis in the direction along the longitudinal axis when the sheave is in the second orientation.

18. A lift assembly as claimed in claim 11, wherein the sheave is pivotably coupled to the portion of the frame about a pivot axis.

19. The lift assembly of claim 1, wherein the sheave is rotated 180 degrees about the fleet axis to move the sheave from the first orientation to the second orientation.

20. The lift assembly of claim 1, wherein the fleet axis does not change when the sheave is coupled to the base in the first and the second orientations.

* * * * *