



US010018338B2

(12) **United States Patent**
Jurik et al.

(10) **Patent No.:** **US 10,018,338 B2**
(45) **Date of Patent:** **Jul. 10, 2018**

(54) **LUMINAIRE WITH ARTICULATED LEDES**

(71) Applicant: **Robe Lighting s.r.o.**, Roznov pod Radhostem (CZ)
(72) Inventors: **Pavel Jurik**, Prostedni Becva (CZ); **Josef Valechar**, Prostedni Becva (CZ)

(73) Assignee: **Robe Lighting s.r.o.**, Roznov pod Radhostem (CZ)

(*) Notice: Subject to any disclaimer, the term of this patent is extended or adjusted under 35 U.S.C. 154(b) by 0 days.

(21) Appl. No.: **15/078,826**

(22) Filed: **Mar. 23, 2016**

(65) **Prior Publication Data**

US 2017/0074497 A1 Mar. 16, 2017

Related U.S. Application Data

(63) Continuation-in-part of application No. 15/024,007, filed as application No. PCT/US2014/066478 on Nov. 20, 2014.

(Continued)

(51) **Int. Cl.**

F21S 4/00 (2016.01)
F21V 21/15 (2006.01)

(Continued)

(52) **U.S. Cl.**

CPC **F21V 21/15** (2013.01); **F21S 10/007** (2013.01); **F21V 5/04** (2013.01); **F21V 7/0091** (2013.01);

(Continued)

(58) **Field of Classification Search**

CPC .. **F21S 8/033**; **F21S 8/04**; **F21V 14/02**; **F21V 21/30**; **F21Y 2115/10**

(Continued)

(56) **References Cited**

U.S. PATENT DOCUMENTS

6,814,459 B2 11/2004 Pederson
9,609,720 B2 3/2017 Woytowicz et al.
(Continued)

FOREIGN PATENT DOCUMENTS

CN 204345517 U 5/2015
WO 2006125792 A1 11/2006

OTHER PUBLICATIONS

Office Action dated May 4, 2017; U.S. Appl. No. 15/024,007, filed Mar. 22, 2016; 10 pages.

(Continued)

Primary Examiner — William Carter

(74) *Attorney, Agent, or Firm* — Conley Rose, P.C.; Grant Rodolph; Brooks W. Taylor

(57) **ABSTRACT**

Described is a method for controlling the movement of LED devices in luminaires, specifically to a method relating to allowing both synchronized and independent pan and tilt movement of LED light modules in a light curtain. The LEDs may be mounted in a plurality of modules. The modules may be in a linear arrangement. The LEDs may be mounted in a plurality of modules that are arrayed in a two dimensional array. The modules in the linear arrangement or in the two dimensional array may be mounted in groups forming modular group assemblies where modular group assembly are independently articulated to pan and/or tilt the modules mounted thereon independent of other modular group assemblies.

9 Claims, 11 Drawing Sheets

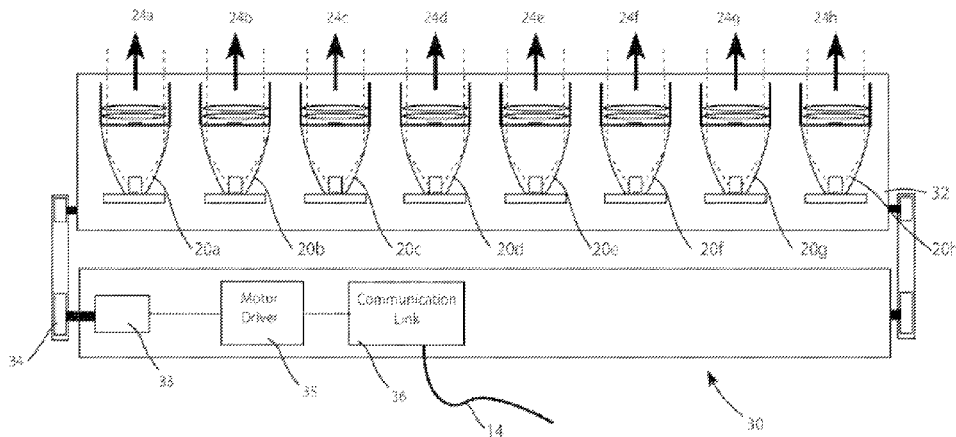

- Related U.S. Application Data**
- (60) Provisional application No. 61/950,381, filed on Mar. 10, 2014, provisional application No. 61/907,818, filed on Nov. 22, 2013.
- (51) **Int. Cl.**
F21V 21/28 (2006.01)
F21V 7/00 (2006.01)
F21V 15/01 (2006.01)
F21V 5/04 (2006.01)
F21S 10/00 (2006.01)
F21V 14/08 (2006.01)
F21Y 115/10 (2016.01)
F21W 131/406 (2006.01)
F21Y 105/10 (2016.01)
- (52) **U.S. Cl.**
 CPC *F21V 14/08* (2013.01); *F21V 15/01* (2013.01); *F21V 21/28* (2013.01); *F21W 2131/406* (2013.01); *F21Y 2105/10* (2016.08); *F21Y 2115/10* (2016.08)
- (58) **Field of Classification Search**
 USPC .. 362/219, 220, 233, 249.03, 249.09, 249.1, 362/418-430
 See application file for complete search history.

- (56) **References Cited**
- U.S. PATENT DOCUMENTS
- | | | | | |
|--------------|-----|---------|------------------|------------|
| 2008/0068839 | A1* | 3/2008 | Matheson | F21S 2/005 |
| | | | | 362/249.07 |
| 2012/0307486 | A1* | 12/2012 | Gordin | F21S 4/00 |
| | | | | 362/223 |
| 2014/0254162 | A1 | 9/2014 | Holland et al. | |
| 2015/0016106 | A1 | 1/2015 | Belliveau et al. | |
| 2015/0062902 | A1 | 3/2015 | Velazquez | |
| 2016/0245490 | A1 | 8/2016 | Jurik et al. | |
- OTHER PUBLICATIONS
- Final Office Action dated Feb. 5, 2018; U.S. Appl. No. 15/024,007, filed Mar. 22, 2016; 9 pages.
 PCT International Search Report; Application No. PCT/US2014/066478; dated Apr. 15, 2015; 3 pages.
 PCT Written Opinion of the International Searching Authority; Application No. PCT/US2014/066478; dated Apr. 15, 2015; 6 pages.
 PCT International Search Report; Application No. PCT/US2017/023872; dated Sep. 5, 2017; 4 pages.
 PCT Written Opinion of the International Searching Authority; Application No. PCT/US2017/023872; dated Sep. 5, 2017; 7 pages.
- * cited by examiner

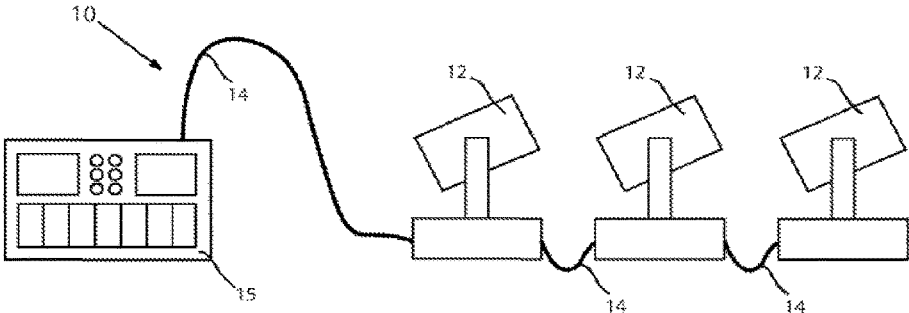

FIG 1
Prior Art

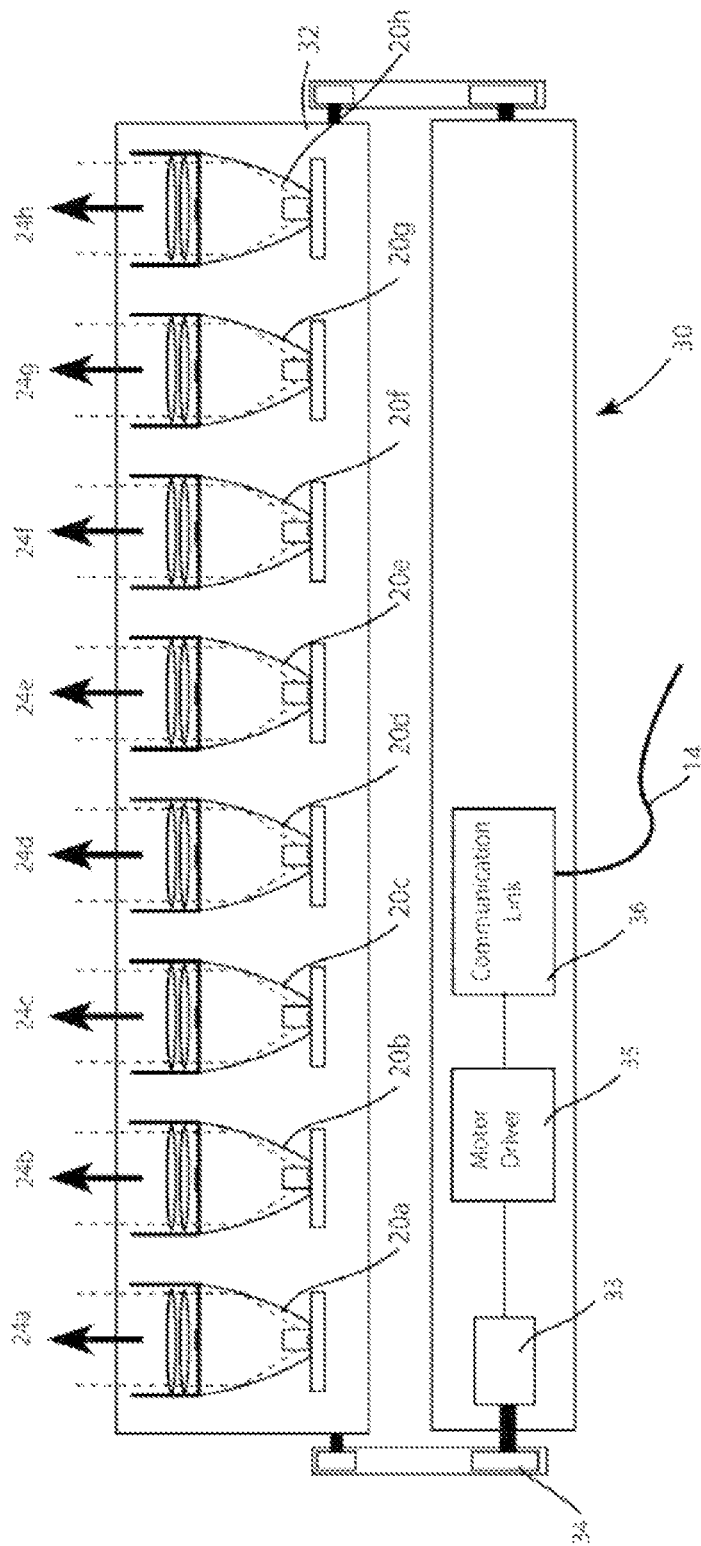

FIG 2

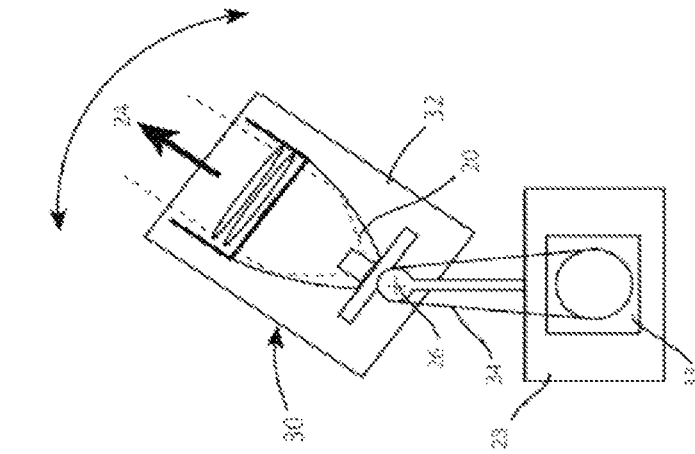

FIG 3

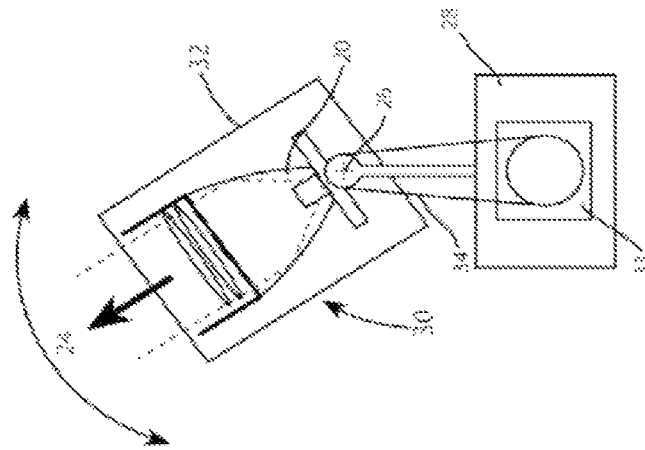

FIG 4

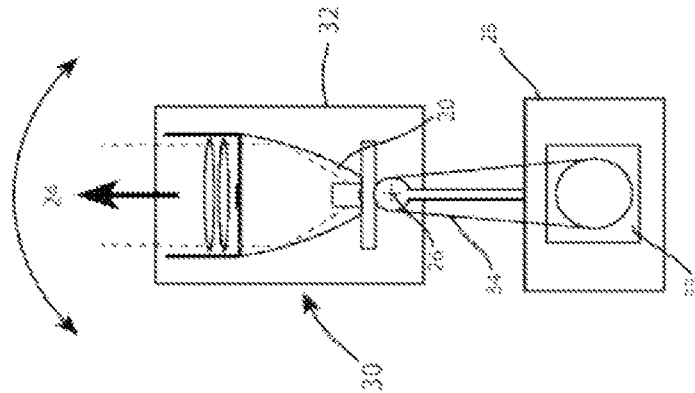

FIG 5

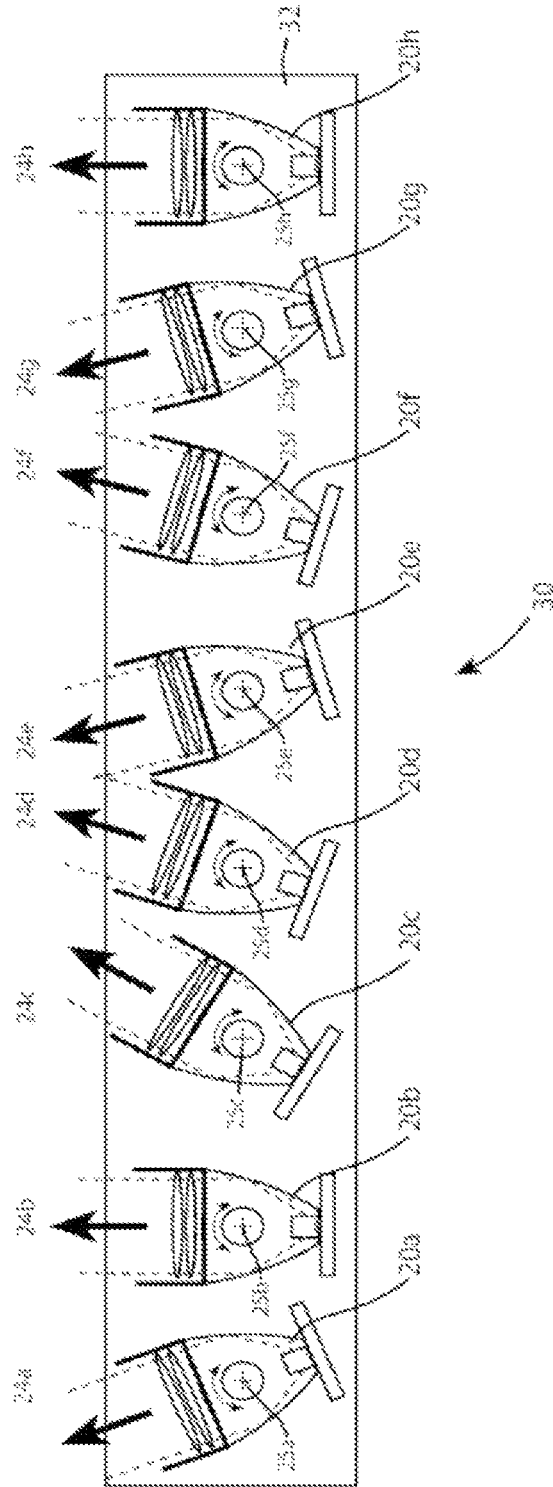

FIG. 6

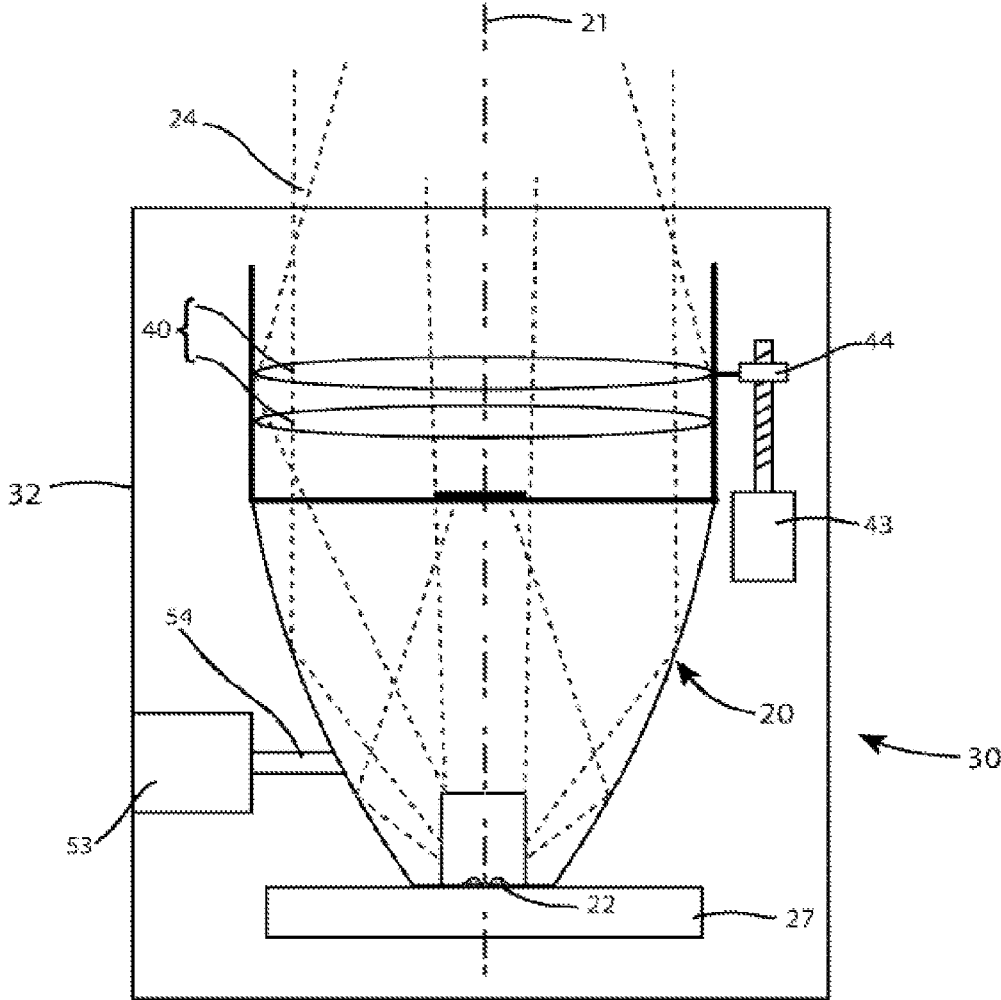

FIG 7

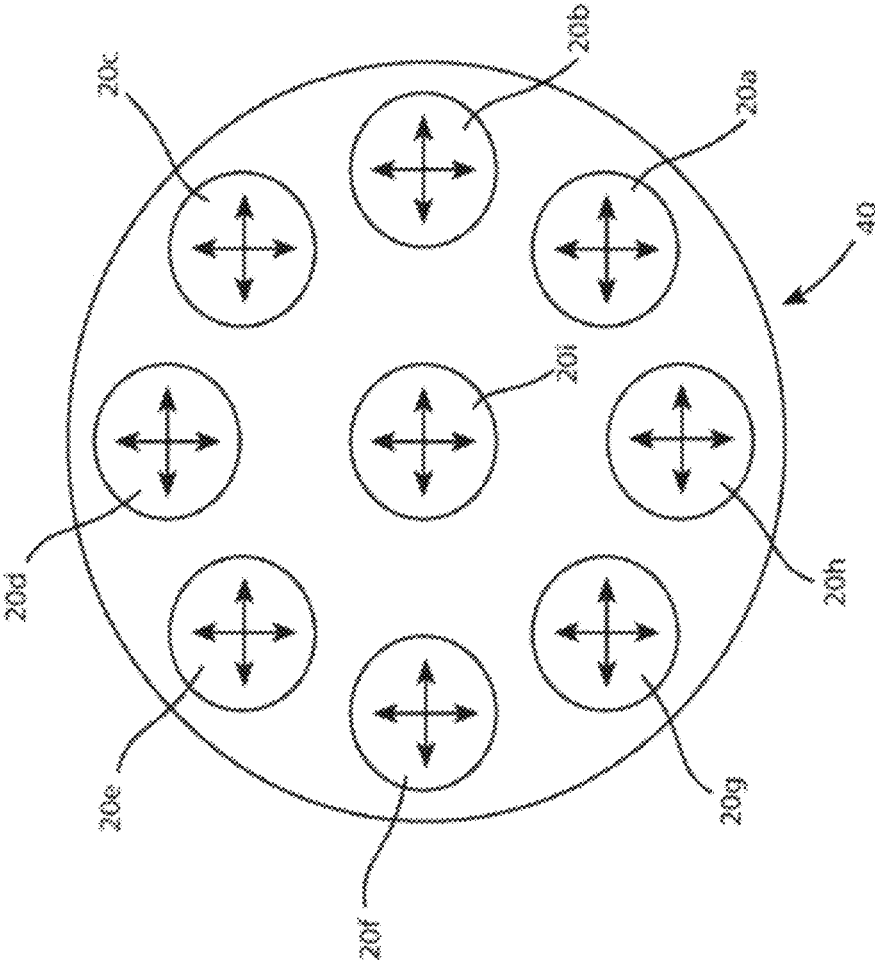

FIG 8

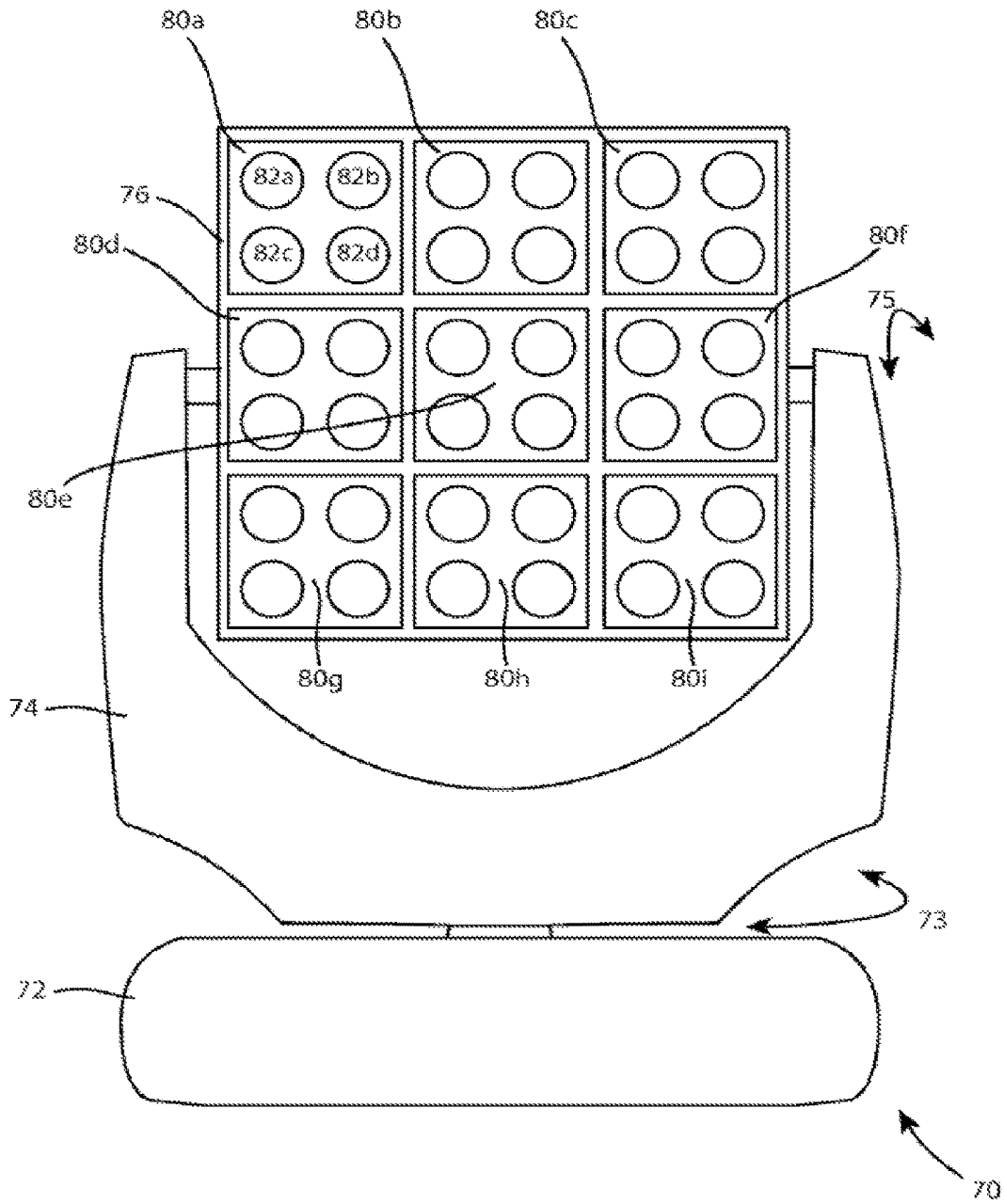

FIG 10

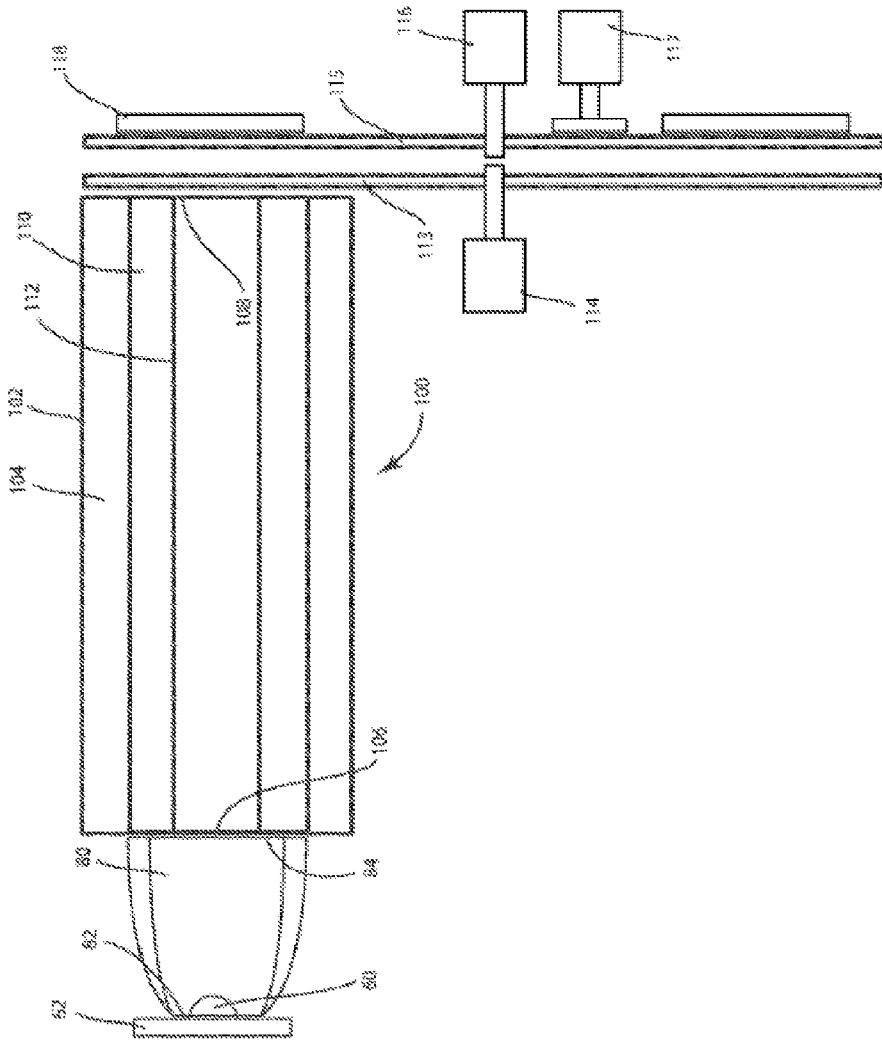

FIG 11

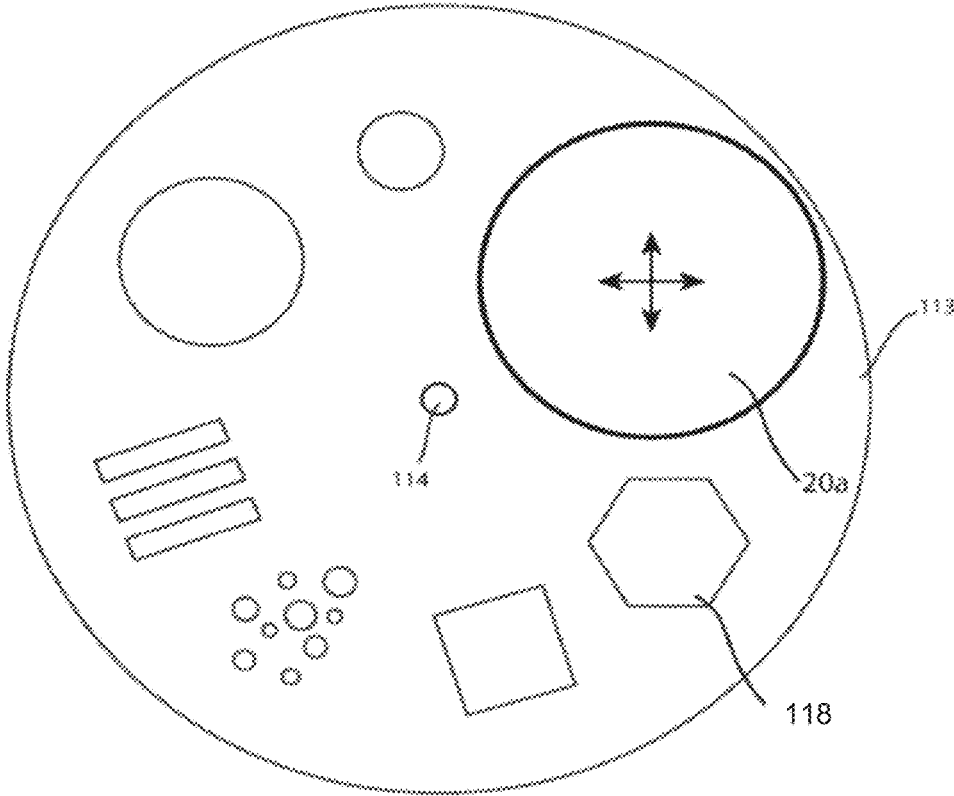

FIG 12

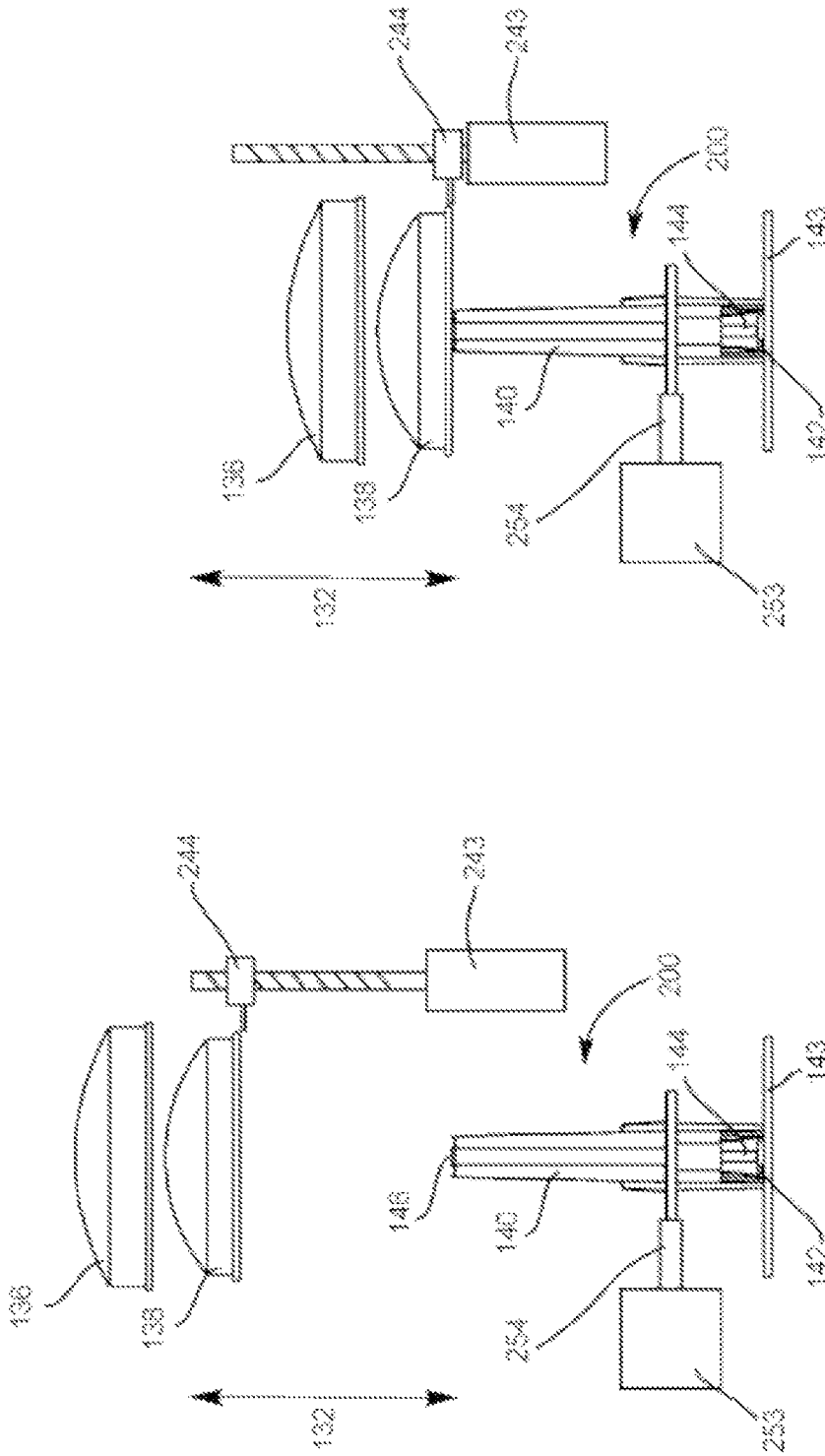

FIG 14

FIG 13

LUMINAIRE WITH ARTICULATED LEDS**CROSS-REFERENCE TO RELATED APPLICATIONS**

This application is a continuation in part of U.S. patent application Ser. No. 15/024,007 filed Mar. 22, 2016 by Pavel Jurik, et al. entitled, "Luminaire with Articulated LEDS", which is a U.S. National Stage of International Patent Application No. PCT/US2014/066478 filed Nov. 20, 2014 by Pavel Jurik, et al. entitled, "Luminaire with Articulated LEDS", which claims priority to U.S. Provisional Application No. 61/950,381 filed Mar. 10, 2014 by Pavel Jurik, et al. entitled, "Method for Controlling the Movement of LEDS in a Luminaire". International Patent Application No. PCT/US2014/066478 also claims priority to U.S. Provisional Application No. 61/907,818 filed Nov. 22, 2013 by Pavel Jurik, et al. entitled, "System and Method for Controlling the Movement of LEDS in a Luminaire."

TECHNICAL FIELD OF THE DISCLOSURE

The present disclosure generally relates to a method for controlling the movement of light emitting diode (LED) devices in luminaires, specifically to a method relating to allowing both synchronized and independent movement of LEDS in a light curtain.

BACKGROUND OF THE DISCLOSURE

Luminaires with automated and remotely controllable functionality are well known in the entertainment and architectural lighting markets. Such products are commonly used in theatres, television studios, concerts, theme parks, night clubs and other venues. A typical product will provide control over the functions of the luminaire allowing the operator to control the intensity and color of the light beam from the luminaire that is shining on the stage or in the studio. Many products also provide control over other parameters such as the position, focus, beam size, beam shape and beam pattern. In such products that contain light emitting diodes (LEDs) to produce the light output it is common to use more than one color of LEDs and to be able to adjust the intensity of each color separately such that the output, which comprises the combined mixed output of all LEDs, can be adjusted in color. For example, such a product may use red, green, blue, and white LEDs with separate intensity controls for each of the four types of LED. This allows the user to mix almost limitless combinations and to produce nearly any color they desire.

FIG. 1 illustrates a typical multiparameter automated luminaire system 10. These systems typically include a plurality of multiparameter automated luminaires 12 which typically each contain on-board a light source (not shown), light modulation devices, electric motors coupled to mechanical drives systems, and control electronics (not shown). In addition to being connected to mains power either directly or through a power distribution system (not shown), each luminaire is connected in series or in parallel to data link 14 to one or more control desks 15. The luminaire system 10 is typically controlled by an operator through the control desk 15.

A known arrangement for luminaires used in the entertainment or architectural market is that of a light curtain. A light curtain consists of a row or line of light emitters arranged so that they produce a plane of light, like a curtain thus the name. Prior art automated products have allowed

the combined movement of all the light emitters together in tilting or rocking motion so as to be able to direct the curtain of light as desired. An example of such a prior art luminaire is the CycFX 8 from Robe Lighting. However, the prior art devices don't allow individual light emitters in the curtain to be adjusted from position(s) independently of each other. Such adjustment would be useful, as it would allow the user or lighting designer to produce converging or diverging curtains, and to direct the light more accurately where it is needed. It would also be useful with other shapes and types of luminaires, not just light curtains, to be able to individually adjust the position of individual light emitters.

There is a need for a method for controlling the movement of LED devices in luminaires, specifically to a method relating to allowing both synchronized and independent movement of LEDS in a light curtain or other luminaires.

BRIEF DESCRIPTION OF THE DRAWINGS

For a more complete understanding of the present disclosure and the advantages thereof, reference is now made to the following description taken in conjunction with the accompanying drawings in which like reference numerals indicate like features and wherein:

FIG. 1 illustrates a multiparameter automated luminaire lighting system;

FIG. 2 illustrates an embodiment of a luminaire with a linear arrangement of a plurality of light emitting modules;

FIG. 3 illustrates the global tilting motion of the light emitting modules in an embodiment of the luminaire illustrated in FIG. 2 where the modules are centrally oriented;

FIG. 4 illustrates the global tilting motion of the light emitting modules in an embodiment of the luminaire illustrated in FIG. 2 where the modules are tilted off of the central orientation illustrated in FIG. 3;

FIG. 5 illustrates the global tilting motion of the light emitting modules in an embodiment of the luminaire illustrated in FIG. 2 where the modules are tilted off of the central orientation illustrated in FIG. 3 but in the opposite direction as illustrated in FIG. 4;

FIG. 6 illustrates an embodiment with independent panning motion of the light emitting modules in an embodiment of the novel luminaire;

FIG. 7 illustrates an embodiment of a light emitting module;

FIG. 8 illustrates a further embodiment of independent panning and tilting motion of the light emitting modules;

FIG. 9 illustrates a further embodiment of independent panning and tilting motion of the light emitting modules;

FIG. 10 illustrates a further embodiment of independent panning and tilting motion of the light emitting modules;

FIG. 11 illustrates an embodiment using a gobo wheel;

FIG. 12 illustrates detail of a gobo wheel embodiment of FIG. 11;

FIG. 13 illustrates an alternative embodiment substituting for light emitting modules in FIGS. 2-7 in a further novel luminaire; and

FIG. 14 illustrates the alternative embodiment of the light emitting module of FIG. 13 with the lens set in a different beam angle position .

DETAILED DESCRIPTION OF THE DISCLOSURE

Preferred embodiments of the novel luminaire are illustrated in the FIGURES, like numerals being used to refer to like and corresponding parts of the various drawings.

The present disclosure generally relates to a method for controlling the movement of LED devices in luminaires, specifically to a method relating to allowing both synchronized and independent movement of LED light modules in a light curtain or other LED luminaires.

FIG. 2 illustrates an embodiment of a luminaire 30 with a linear arrangement of a plurality of light-emitting modules. In the embodiment illustrated eight light-emitting modules 20a-h are mounted within luminaire body 32 which serves as a common carrier to carry the modules 20a-h in a linear arrangement to form light curtain luminaire 30. Each light-emitting module 20a-h emits collimated and controlled light beams 24a-h. Each of these light-emitting modules 24a-h may be individually adjusted for color, by adjusting the output mix of its LED emitters, and for beam angle, by adjusting each modules optical elements. In this configuration all the light-emitting modules are aligned to point in the same direction and same plane. The luminaire body 32 may be articulated to be capable of a global tilting motion through motor 33 and drive mechanism 34. Motor 33 may be controlled from data link 14 through communication link 36 and motor driver 35. Though not shown in this figure the common carrier may also be articulated to be capable of a global panning motion through motors and motor drivers which are controlled by an operator through the communications link 36.

FIGS. 3, 4, and 5 illustrate the global tilting motion of the light-emitting modules in an embodiment of the disclosure. The view in FIGS. 3, 4, and 5 is an elevation view of the luminaire 30 shown in FIG. 2, viewed from the end of the luminaire, orthogonal to that shown in FIG. 2. Luminaire body 32 may be pivotably mounted to frame 28 such that the luminaire body can rotate about pivot axis 26. FIG. 3 shows the luminaire body 32 positioned such that the light-emitting modules 20 are vertical and light beams 24 are emitted vertically. FIGS. 4 and 5 show the luminaire body rotated around pivot axis 26 such that the light-emitting modules 20, and thus the light beams 24, are tilted to the left and right respectively.

This tilting motion around pivot axis 26 is controlled through a motor 33 and drive mechanism 34 actuation/articulation system. The actuation/articulation system may be a stepper motor, servo motor, linear actuator, solenoid, direct current (DC) motor, or other mechanism many of which are well known in the art. This tilting motion may be controlled remotely as with other features of an automated luminaire, perhaps through an industry standard protocol such as DMX-512 through data link 14, communication link 36, and motor driver 35 on board the luminaire. In other embodiments, configurations are possible. This tilting motion imparts the same movement to each and every light-emitting module in luminaire 30 identically. They will all move in parallel and mechanical synchronization.

FIG. 6 illustrates the independent panning motion of the light emitting modules in an embodiment of the disclosure. FIG. 6 shows the same view of luminaire 30 as FIG. 2. In this embodiment light-emitting modules 20a-h are each individually and separately pivotably mounted to luminaire body 32 such that the light-emitting modules 20a-h can individually rotate about respective pivot axes 25a-h. The plane of rotation of pivot axes 25a-h is orthogonal to pivot axis 26 shown in FIGS. 3, 4, and 5. Pivot axes 25a-h allow each light-emitting module 20a-h to pan from side to side individually and independent of the position of its neighboring light-emitting modules, thus allowing light beams 24a-h to be individually and separately steered. These individual independent tilt articulators tilting motion around

pivot axes 25a-h may be actuated through a stepper motor, servo motor, linear actuator, solenoid, DC motor, or other mechanism as well known in the art.

FIG. 7 illustrates the light-emitting module 20 of an embodiment of the disclosure. LED emitters 22 may be mounted to or be otherwise in thermal contact with a heat sink 27. The optics of light-emitting module 20 may comprise total internal reflection (TIR) optical systems or standard reflectors such as are well known in the art so as to provide a collimated light beam 24 along the optical axis 21. Light-emitting module 20 may further contain optical elements 40 such that the focal length and thus the beam angle of the emitted light may be adjusted. Such focal length adjusting optical elements 40 are coupled via drive mechanism 44 to a motor 43 such that the beam angle change can be remotely controlled. This actuation system may be a stepper motor, servo motor, linear actuator, solenoid, DC motor, or other mechanism many of which are well known in the art.

In various embodiments of the disclosure each LED emitter 22 may comprise a single LED die of a single color or a group of LED dies of the same or differing colors. For example in one embodiment LED emitter 22 may comprise one each of a Red, Green, Blue and White LED die. In further embodiments LED emitter 22 may comprise LED chip or package while in yet further embodiments LED emitter 22 may comprise multiple LED chips or packages either under a single primary optic or each package with its own primary optic. In some embodiments these LED die(s) may be paired with optical lens element(s) as part of the LED light-emitting module.

The two orthogonal movements described herein about pivot axes 25 a-h, and 26 are commonly referred to as pan and tilt directions. In operation the user or lighting designer may rotate the entire luminaire 30 around the tilt pivot axis 26, and individually pan each light-emitting module 20a-h in order to achieve the desired effect from the luminaire light curtain. FIG. 7 illustrates an independent pan articulator employing a direct motor drive 53, 54 of the actuation system for panning an individual light-emitting module 20. This actuation system may be a stepper motor, servo motor, linear actuator, solenoid, DC motor, or other mechanism many of which are well known in the art.

FIG. 8 illustrates a further embodiment of the disclosure. In this embodiment, 9 light-emitting modules 20a-20i are mounted in a luminaire 40. Each light-emitting module 20a-20i emits collimated and controlled light. Each of the light beams from the light-emitting modules 20a-20i may be individually adjusted for color, by adjusting the output mix of its LED emitters, and for beam angle, by adjusting each modules optical elements as previously described. Further, each light-emitting module 20a-20i may be individually articulated to adjusted for both pan and tilt. This differs from the prior embodiment where each light-emitting module had a single independent axis of tilt movement, and a global movement of the luminaire provided pan. In the embodiment illustrated in FIG. 8 each light-emitting module 20a-20i is capable of both independent pan and independent tilt. Further, luminaire 40 may also have global pan and global tilt available. Independent pan and tilt of each light-emitting module 20a-20i provide the ability to widen and narrow the combined beam produced by the modules, while the global pan and tilt of luminaire 40 provides the ability, as usually provided by an automated luminaire, to steer the resultant combined beam as desired.

FIG. 9 illustrates a further embodiment of the disclosure. In this embodiment, 37 light-emitting modules are mounted

5

in the head **56** of luminaire **50**. The light-emitting modules are mounted in groups to form seven module group assemblies, **60a-60g**. For example, module group assembly **60a** contains five light-emitting modules **62a-62e**. Each of the 37 light-emitting modules emits collimated and controlled light. Each of the light beams from the light-emitting modules may be individually adjusted for color, by adjusting the output mix of its LED emitters, and for beam angle, by adjusting each module optical elements as previously described. In the embodiment illustrated in FIG. **9** each module group assembly **60a-60g** is capable of both independent pan and independent tilt.

Head **56** may be mounted in a yoke assembly **94** that, in turn, is mounted on base **52**. Yoke assembly **94** is rotatably mounted on base **52** so as to provide global pan rotation **93** and head **56** is rotatably mounted in yoke assembly **94** so as to provide global tilt rotation **55**.

FIG. **10** illustrates a further embodiment of the disclosure. In this embodiment 36 light-emitting modules are mounted in the head **76** of luminaire **70**. The light-emitting modules are mounted in groups to form nine module group assemblies, **80a-80i**. For example, module group assembly **80a** contains four light-emitting modules **82a-82d**. Each of the 36 light-emitting modules emits collimated and controlled light. Each of the light beams from the light-emitting modules may be individually adjusted for color, by adjusting the output mix of its LED emitters, and for beam angle, by adjusting each module optical elements as previously described. In the embodiment illustrated in FIG. **10** each module group assembly **80a-80i** is capable of both independent pan and independent tilt.

Head **76** may be mounted in a yoke assembly **74** that, in turn, is mounted on base **72**. Yoke assembly **74** is rotatably mounted on base **72** so as to provide global pan rotation **73** and head **76** is rotatably mounted in yoke assembly **74** so as to provide global tilt rotation **75**.

Although the embodiments illustrated herein show specific numbers of light-emitting modules mounted in specific numbers of module assemblies, in practice the disclosure is not so limited and any number of light-emitting modules may be mounted in any number of module assemblies to form a luminaire. In any of the possible arrangements, each of the light-emitting modules and/or each of the module assemblies may be capable of independent pan and independent tilt movement in one or more axes. Further, the light-emitting modules and/or module assemblies may be arranged in any shape or layout. Embodiments herein illustrate linear, round and square arrangements, but any arrangement shape may be used.

FIG. **11** illustrates a further embodiment of the light-emitting module **100** of the disclosure. LED **60**, which may include a primary optic, is mounted on substrate **62**. LED **60** may contain a single color die or may contain multiple dies, each of which may be of differing colors. The light output from the dies in LED **60** enters collimating and mixing optic **80** at light entry port **82**. Collimating and mixing optic **80** may be a solid optic using total internal reflection (TIR) to direct the light or may be a hollow reflective surface. Collimating and mixing optic **80** may have four sides, each of which may be curved with cornered sides. The combination square sided shape with curved sides provides excellent mixing of the light from the dies in LED **60**. A further feature of collimating and mixing optic **80** is that it directs the reflected light to an external focal point that is comparatively close to its output port **84** of the collimating and mixing optic **80**. In the embodiment shown in FIG. **11**, the reflected light exits collimating and mixing optic **80** at

6

output port **84** and enters light integrator optic **102** at its entry port **106**. Light integrator optic **102** is a device utilizing internal reflection so as to collect, homogenize and constrain and conduct the light from collimating and mixing optic **80**. Light integrator optic **102** may be a hollow tube with a reflective inner surface such that light impinging into the entry port **106** may be reflected multiple times along the tube before leaving at the exit port **108**. Light integrator optic **102** may be a square tube, a hexagonal tube, a heptagonal tube, an octagonal tube, a circular tube, or a tube of any other cross section. In a further embodiment, light integrator optic **102** may be a solid rod constructed of glass, transparent plastic or other optically transparent material where the reflection of the incident light beam within the rod is due to total internal reflection (TIR) from the interface between the material of the rod and the surrounding air. The integrating rod may be a square rod, a hexagonal rod, a heptagonal rod, an octagonal rod, a circular rod, or a rod of any other cross section. Integrator embodiments with a polygonal cross section have reflective sides **110** and corners **112** between the reflective sides as seen in FIG. **11** which includes a side cross sectional view of the light integrator optic **102**.

A feature of a light integrator optic **102**, which comprises a hollow tube or solid rod where the sides of the rod or tube are essentially parallel and the entry point **106** and exit port **108** are of the same size, is that the divergence angle of light exiting the light integrator optic **102** at exit port **108** will be the same as the divergence angle for light entering the light integrator optic **102** at entry port **106**. Thus, a parallel sided light integrator optic **102** has no effect on the beam divergence and will transfer the position of the focal point of collimating and mixing optic **80** at its output port **84** to the light integrator optic's **102** exit port **108**. The light exiting light integrator optic **102** will be well homogenized with all the colors of LED **60** mixed together into a single colored light beam and may be used as our output, or may be further modified by downstream optical systems.

Light integrator optic **102** may advantageously have an aspect ratio where its length is much greater than its diameter. The greater the ratio between length and diameter, the better the resultant mixing and homogenization will be. Light integrator optic **102** may be enclosed in a tube or sleeve **104** that provides mechanical protection against damage, scratches, and dust.

In the embodiment illustrated in FIG. **11**, the optical system is further fitted with a gobo wheel **113**. A gobo wheel contains patterns or images that will controllably mask the light exiting through exit port **108**. These images will then be projected by downstream optical elements to create a pattern projecting light beam. The lens system after the gobo wheel **113** may be a zoom lens system **40** such as shown in FIG. **7** or any other projecting lens system as well known in the art. Gobo wheel **113** may be rotated through motor **114** in order to select different gobo patterns in front of exit port **108**. A rotating gobo wheel **115** may additionally or alternatively be utilized in the system. Rotating gobo wheel **115** may be rotated through motor **116** in order to select different gobo patterns **118** in front of exit port **108**. Gobo patterns **118** may then be rotated about the optical axis of the system through motor **117**.

FIG. **12** shows gobo wheel **113** in more detail in a further embodiment of the disclosure. Gobo wheel **113** contains a plurality of gobo patterns **118** that may be moved across and in front of light-emitting module **20a** by rotation about motor **114** and will move with it as it is panned and tilted. In other embodiments, every light-emitting module as illus-

trated in FIG. 7, 8, 9 or 10 may be fitted with a gobo wheel, all or any of which may be individually or cooperatively controlled. In further embodiments, the gobo wheel may not be a complete circular disc as shown in FIG. 12, but may be a portion of a disc, or a flag so as to save space and provide a more limited number of gobo patterns 118. The gobo patterns 118 may be of any shape and may include colored images or transparencies. In yet further embodiments, individual gobo patterns 118 may be further rotated about their axes by supplementary motors in order to provide a moving rotating image. Such rotating gobo wheels are well known in the art.

FIGS. 13 and 14 illustrate an alternative embodiment of the light-emitting and optical module 200 of the disclosure. These modules would replace the modules 20 in the previously illustrated luminaires. A light-emitting module 200 of the system comprises an LED 142, which may or may not include a primary optic, mounted on substrate 143. LED 142 may contain a single color die or may contain multiple dies, each of which may be of differing colors. The light output from the dies in LED 142 enters light integrator optic 144 contained within protective sleeve 140. Light integrator optic 144 may be a device utilizing internal reflection so as to collect, homogenize and constrain and conduct the light to exit port 146. Light integrator optic 144 may be a hollow tube with a reflective inner surface such that light impinging into the entry port may be reflected multiple times along the tube before leaving at the exit port 146. Light integrator optic 144 may be a square tube, a hexagonal tube, a heptagonal tube, an octagonal tube, a circular tube, or a tube of any other cross section. In a further embodiment, light integrator optic 144 may be a solid rod constructed of glass, transparent plastic or other optically transparent material where the reflection of the incident light beam within the rod is due to total internal reflection (TIR) from the interface between the material of the rod and the surrounding air. The integrating rod may be a square rod, a hexagonal rod, a heptagonal rod, an octagonal rod, a circular rod, or a rod of any other cross section.

The light integrator optic 144 will be elongated enough to well homogenize all the colors of LED 142 together into a single colored light beam. In various embodiments of the disclosure each LED 142 may comprise a single LED die of a single color or a group of LED dies of the same or differing colors. For example, in one embodiment LED 142 may comprise one each of a Red, Green, Blue and White LED die. In further embodiments, LED 142 may comprise a single LED chip or package while in yet further embodiments LED 142 may comprise multiple LED chips or packages either under a single primary optic or each package with its own primary optic. In some embodiments these LED die(s) may be paired with optical lens element(s) as part of the LED light-emitting module. In a further embodiment LED 142 may comprise more than four colors of LEDs. For example seven colors may be used, one each of a Red, Green, Blue, White, Amber, Cyan, and Deep Blue/UV LED die.

Light integrator optic 144 may advantageously have an aspect ratio where its length is much greater than its diameter. The greater the ratio between length and diameter, the better the resultant mixing and homogenization will be. The precise length is dependent on the placement of LED color dies in the LED array served by the light integrator optic 144 to get homogenization. One configuration may require a greater ratio of length to diameter to another and different configurations may require different input cross-sectional areas and thus more length to get well-mixed output. The

shape of the cross sections and changes in the cross section also effect the length of integrator required. Light integrator optic 144 may be enclosed in a tube or sleeve 140 that provides mechanical protection against damage, scratches, and dust.

In further embodiments the light integrator optic 144, whether solid or hollow, and with any number of sides, may have entry ports and exit ports that differ in shape. For example, a square entry port and an octagonal exit port 146. Further light integrator optic 144 may have sides which are tapered so that the entrance aperture is smaller than the exit aperture. The advantage of such a structure is that the divergence angle of light exiting the light integrator optic 144 at exit port 146 will be smaller than the divergence angle for light entering the light integrator optic 144. The combination of a smaller divergence angle from a larger aperture serves to conserve the etendue of the system. Thus, a tapered light integrator optic 144 may provide similar functionality to a condensing optical system.

Light exiting light integrator optic 144 is directed towards and through first lens 136 and second lens 138 that serve to further control the angle of the emitted light beam. First lens 136 and second lens 138 may be moved as a pair towards and away from light integrator optic 144 as described above in the direction along the optical axis of the system as shown by arrow 132. In the position shown in FIG. 13 where first lens 136 and second lens 138 are at their furthest separation from the light-emitting module and the exit port 146 of light integrator optic 144 the emitted light beam will have a narrow beam angle. In the position shown in FIG. 14 where first lens 136 and second lens 138 are at their closest distance to the light-emitting module and the exit port 146 of light integrator optic 144 the emitted light beam will have a wide beam angle. Intermediate positions of the lenses 136 and 138 with respect to exit port 146 of light integrator optic 144 will provide intermediate beam angles. In one embodiment of the disclosure, the range of beam angles from the system may be adjusted from 4° to 50°.

Lenses 136 and 138 may be mechanically driven 244 by a motor 243 such that the beam angle change can be remotely controlled. This actuation system may be a stepper motor, servo motor, linear actuator, solenoid, DC motor, or other mechanism, many of which are well known in the art.

FIGS. 13 and 14 further illustrate an independent pan articulator employing a direct motor drive 253, 254 of the actuation system for panning an individual light module 200. This actuation system may be a stepper motor, servo motor, linear actuator, solenoid, DC motor, or other mechanism, many of which are well known in the art.

In further embodiments, lenses 136 and 138 may move separately and independently to provide varying beam angle or focus adjustment of the light beam.

Lenses 136 and 138 may be meniscus lenses, plano convex lenses, bi-convex lenses, holographic lenses, or other lenses as well known in the art. Lenses 136 and 138 may be manufactured from glass, acrylic, polycarbonate, or any other material known to be used for optical lenses. Lenses 136 and 138 may be single elements or may each be lenses comprising a plurality of elements. Such elements may be cemented together or air spaced as is well known in the art. Lenses 136 and 138 may be constructed so as to form an achromatic combination. Such a configuration may be desirable such that the differing wavelengths of light from the associated LED light emitting module do not diverge or converge from each other and remain mixed. The design of such achromatic lenses or lens assemblies is well known in the art.

While the disclosure has been described with respect to a limited number of embodiments, those skilled in the art, having benefit of this disclosure, will appreciate that other embodiments may be devised which do not depart from the scope of the disclosure as disclosed herein. The disclosure has been described in detail, it should be understood that various changes, substitutions and alterations can be made hereto without departing from the spirit and scope of the disclosure.

What is claimed is:

1. A luminaire comprising:
 - a plurality of module group assemblies into each of which is mounted at least one light emitting module;
 - a head in which the plurality of module group assemblies is mounted in a coplanar arrangement;
 - a global articulator is a first global articulator configured to articulate the head around a first axis of rotation parallel to the plane of the coplanar arrangement and the luminaire further comprises a second global articulator configured to articulate the head around a fourth axis of rotation orthogonal to the first axis of rotation;
 - a first plurality of independent articulators, each of which is configured to articulate a corresponding module group assembly about an individual second axis of rotation parallel to the plane of the coplanar arrangement; and
 - a second plurality of independent articulators, each of which is configured to articulate a corresponding module group assembly about an individual third axis of

rotation parallel to the plane of the coplanar arrangement and orthogonal to the second axis of rotation of the module group.

2. The luminaire of claim 1, wherein the first and second global articulators comprise respective first and second electric motors.
3. The luminaire of claim 1, wherein the first and second pluralities of independent articulators comprise corresponding first and second pluralities of electric motors.
4. The luminaire of claim 1, wherein at least one of the light emitting modules comprises an LED.
5. The luminaire of claim 4, wherein the at least one of the light emitting modules comprises one each of red, green, blue, and white LED dies.
6. The luminaire of claim 4, wherein the at least one of the light emitting modules is configured to be adjusted for at least one of color and beam angle of a light beam emitted by the light emitting module.
7. The luminaire of claim 4, wherein the at least one of the light emitting modules comprises a system of one or more lenses configured to adjust at least one of beam angle and focus of a light beam emitted by the light emitting module.
8. The luminaire of claim 4, wherein the at least one of the light emitting modules comprises at least one of a gobo wheel and a rotating gobo wheel.
9. The luminaire of claim 4, wherein the at least one of the light emitting modules comprises at least one of a collimating and mixing optic and a light integrator optic.

* * * * *