



US010015868B2

(12) **United States Patent**
Quilici et al.

(10) **Patent No.:** **US 10,015,868 B2**
(45) **Date of Patent:** ***Jul. 3, 2018**

(54) **SOLID-STATE LAMPS WITH ELECTRONICALLY ADJUSTABLE LIGHT BEAM DISTRIBUTION**

(71) Applicant: **Osram Sylvania Inc.**, Wilmington, MA (US)

(72) Inventors: **Michael Quilici**, Essex, MA (US); **Seung Cheol Ryu**, Marblehead, MA (US); **Lori Brock**, Ipswich, MA (US)

(73) Assignee: **OSRAM SYLVANIA Inc.**, Wilmington, MA (US)

(*) Notice: Subject to any disclaimer, the term of this patent is extended or adjusted under 35 U.S.C. 154(b) by 0 days.
This patent is subject to a terminal disclaimer.

(21) Appl. No.: **14/531,427**

(22) Filed: **Nov. 3, 2014**

(65) **Prior Publication Data**
US 2016/0123541 A1 May 5, 2016

(51) **Int. Cl.**
H05B 37/00 (2006.01)
H05B 37/02 (2006.01)
(Continued)

(52) **U.S. Cl.**
CPC **H05B 37/0272** (2013.01); **F21K 9/233** (2016.08); **F21V 29/70** (2015.01);
(Continued)

(58) **Field of Classification Search**
CPC H05B 33/08; H05B 37/02
(Continued)

(56) **References Cited**

U.S. PATENT DOCUMENTS

5,561,346 A * 10/1996 Byrne F21K 9/13 313/113
7,344,279 B2 * 3/2008 Mueller F21V 29/83 362/240

(Continued)

FOREIGN PATENT DOCUMENTS

GB 2374919 A 10/2002
KR 20090000762 1/2009

(Continued)

OTHER PUBLICATIONS

Prouteau, Evelyne, International Search Report and Written Opinion of the International Searching Authority, for counterpart application PCT/US2015/058540, dated Jan. 4, 2016, European Patent Office, Rijswijk, The Netherlands, 12 pages.

(Continued)

Primary Examiner — Thuy Vinh Tran

(74) *Attorney, Agent, or Firm* — Yutian Ling

(57) **ABSTRACT**

Solid-state lamps having an electronically adjustable light beam distribution are disclosed. In accordance with some embodiments, a lamp configured as described herein includes a plurality of solid-state emitters (addressable individually and/or in groupings) mounted over a non-planar interior surface of the lamp. The interior mounting surface can be concave or convex, as desired, and may be of hemispherical or hyper-hemispherical geometry, among others, in accordance with some example embodiments. In some embodiments, the heat sink of the lamp may be configured to provide the interior mounting surface, whereas in some other embodiments, a separate mounting interface, such as a parabolic aluminized reflector (PAR), a bulged reflector (BR), or a multi-faceted reflector (MR), may be included to such end. Also, the lamp may include one or more focusing optics for modifying its output. In some

(Continued)

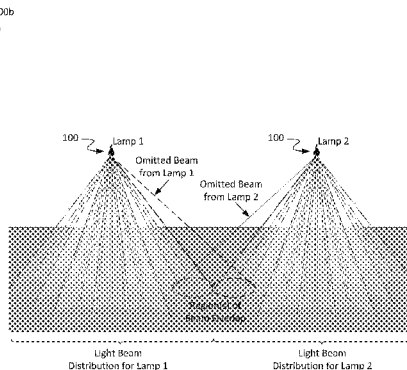
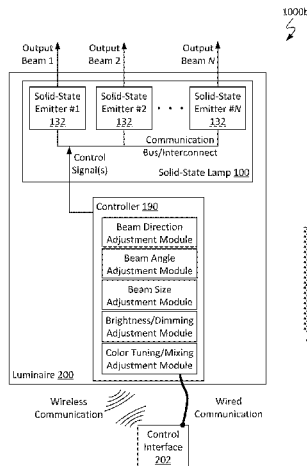

cases, a lamp provided as described herein may be configured for retrofitting existing lighting structures.

17 Claims, 15 Drawing Sheets

(51) **Int. Cl.**

F21V 29/70 (2015.01)
F21K 9/233 (2016.01)
H05B 33/08 (2006.01)
F21W 131/406 (2006.01)
F21S 8/02 (2006.01)
F21Y 115/10 (2016.01)
F21Y 107/00 (2016.01)
F21Y 107/10 (2016.01)
F21Y 107/20 (2016.01)

(52) **U.S. Cl.**

CPC **H05B 33/0803** (2013.01); **H05B 33/0857** (2013.01); **F21S 8/026** (2013.01); **F21W 2131/406** (2013.01); **F21Y 2107/00** (2016.08); **F21Y 2107/10** (2016.08); **F21Y 2107/20** (2016.08); **F21Y 2115/10** (2016.08); **H05B 33/08** (2013.01); **H05B 37/02** (2013.01)

(58) **Field of Classification Search**

USPC 315/51, 185 R, 246, 247, 291, 294, 299; 362/235, 249.02
 See application file for complete search history.

(56)

References Cited

U.S. PATENT DOCUMENTS

9,080,729 B2* 7/2015 Jiang F21K 9/135
 9,097,396 B2* 8/2015 Rowlette, Jr. G02B 6/0008

2010/0046226 A1 2/2010 Cox et al.
 2011/0051420 A1 3/2011 Gill
 2012/0026732 A1 2/2012 Fricke
 2012/0112661 A1 5/2012 van de Ven et al.
 2012/0113640 A1 5/2012 Markle et al.
 2012/0169953 A1 7/2012 Kataoka et al.
 2012/0206918 A1 8/2012 Lee et al.
 2014/0022784 A1* 1/2014 Dohn F21K 9/135
 362/235
 2014/0160744 A1 6/2014 Wimberly
 2014/0175966 A1 6/2014 Tan
 2014/0301071 A1* 10/2014 Jorgensen F21V 14/06
 362/231
 2015/0130365 A1* 5/2015 Kim H05B 37/0272
 315/209 R
 2015/0334789 A1* 11/2015 van de Ven H05B 33/02
 313/498
 2016/0330825 A1* 11/2016 Recker H05B 37/0272

FOREIGN PATENT DOCUMENTS

WO 0124583 A1 4/2001
 WO 2007125520 A1 11/2007
 WO 2008152561 A1 12/2008

OTHER PUBLICATIONS

Prouteau, Evelyne, International Search Report and Written Opinion of the International Searching Authority, for application PCT/US2015/058537, dated Jan. 11, 2016, European Patent Office, Rijswijk, The Netherlands, 12 pages.
 Martinez Orta, Maxima, International Search Report and Written Opinion of the International Searching Authority, for application PCT/US2015/058539, dated Mar. 17, 2016, European Patent Office, Rijswijk, The Netherlands, 11 pages.

* cited by examiner

Figure 1A

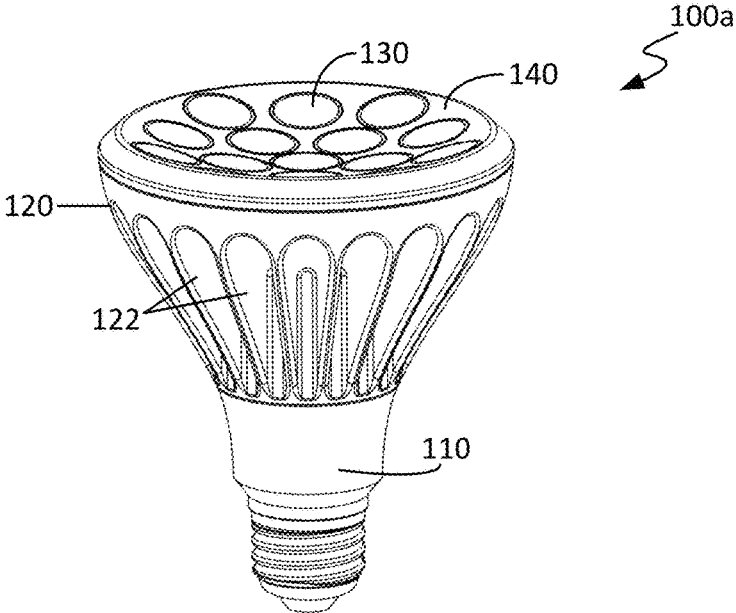

Figure 1B

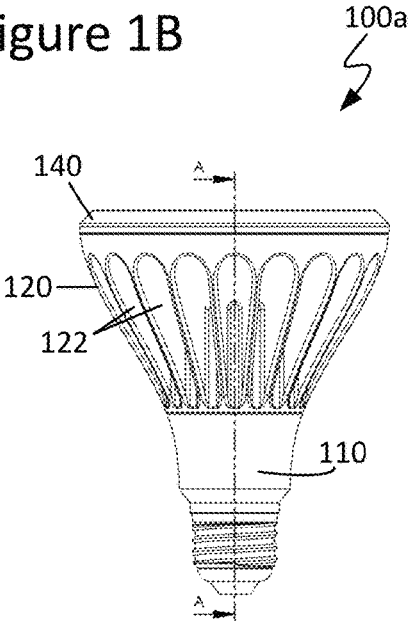

Figure 1C

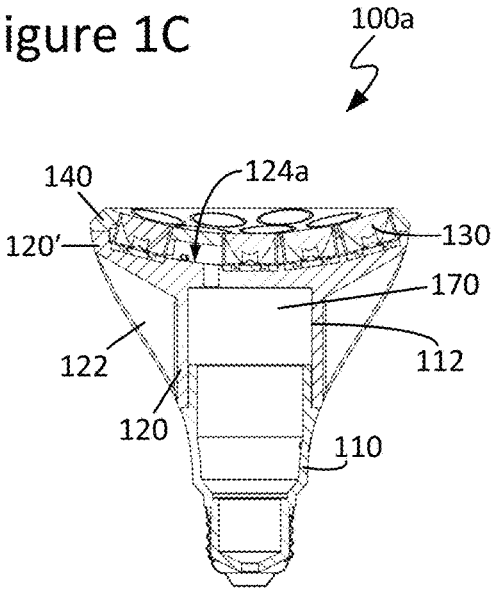

Figure 2A

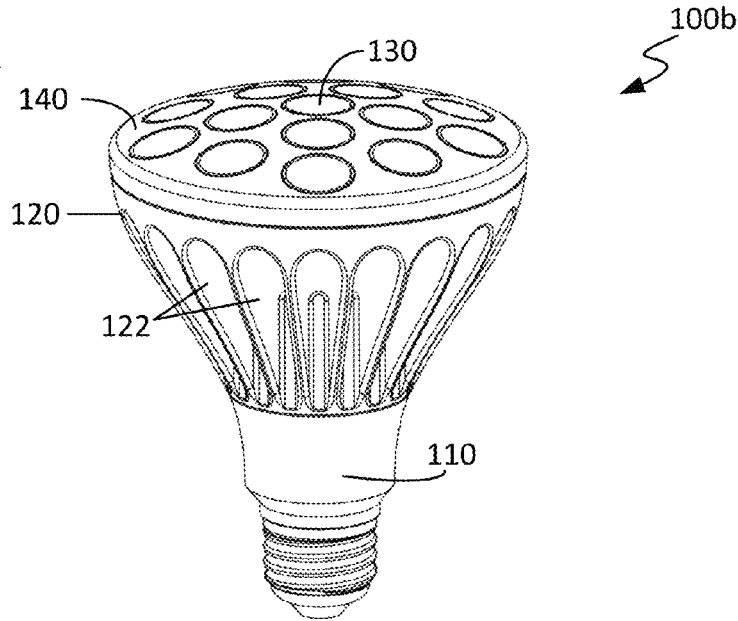

Figure 2B

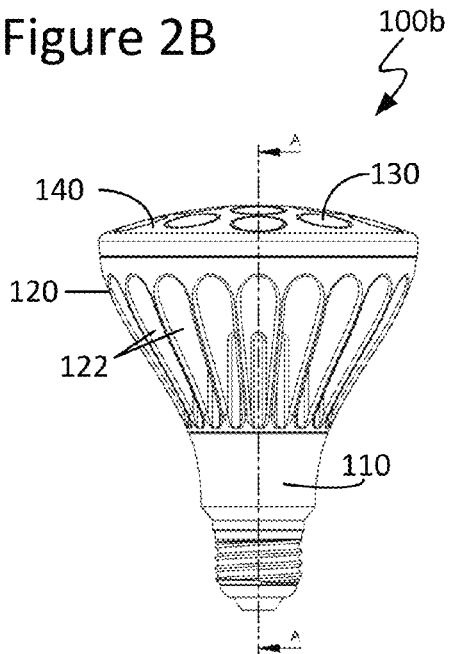

Figure 2C

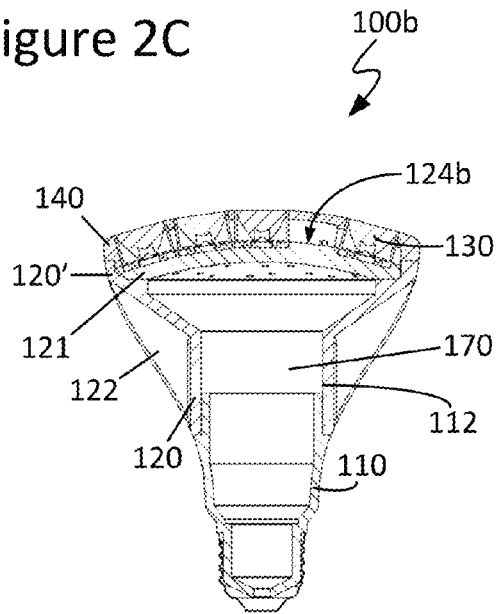

Figure 3

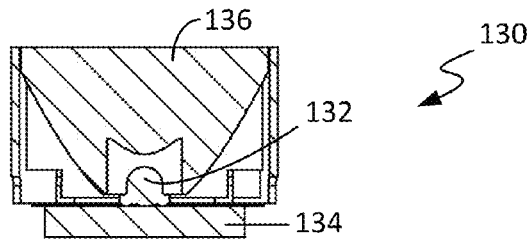

Figure 4A

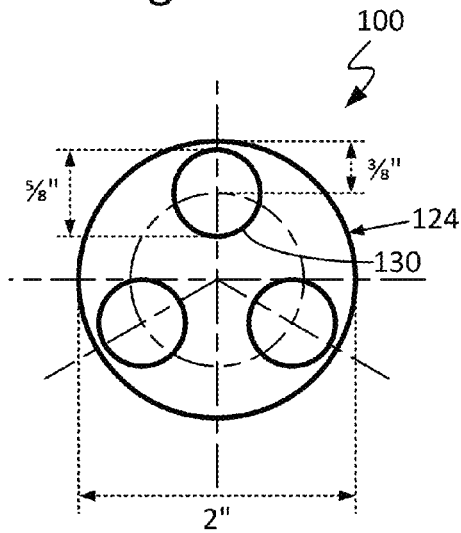

Figure 4B

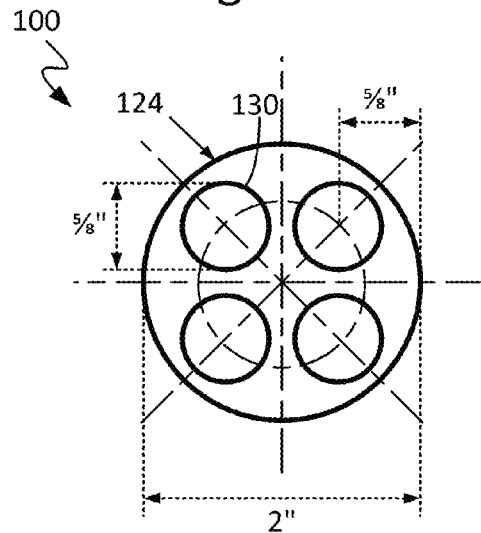

Figure 4C

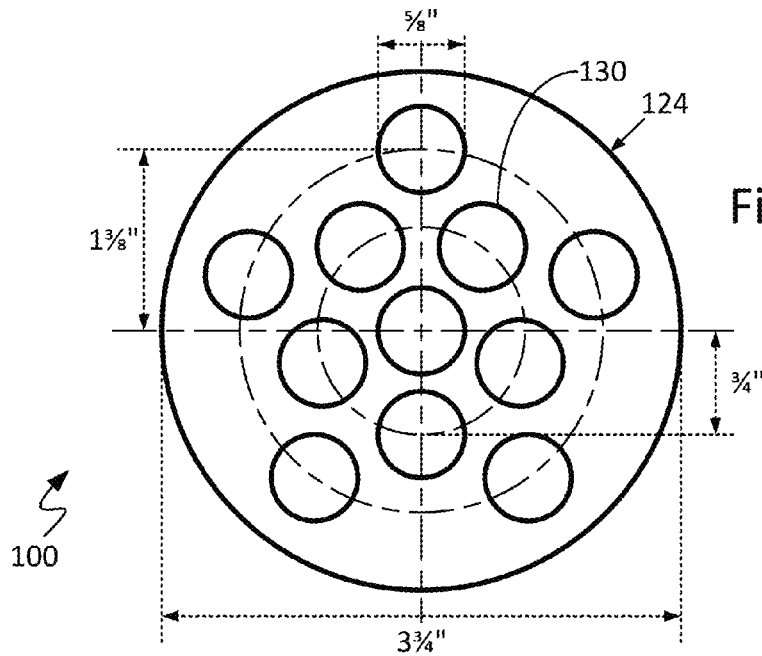

Figure 5

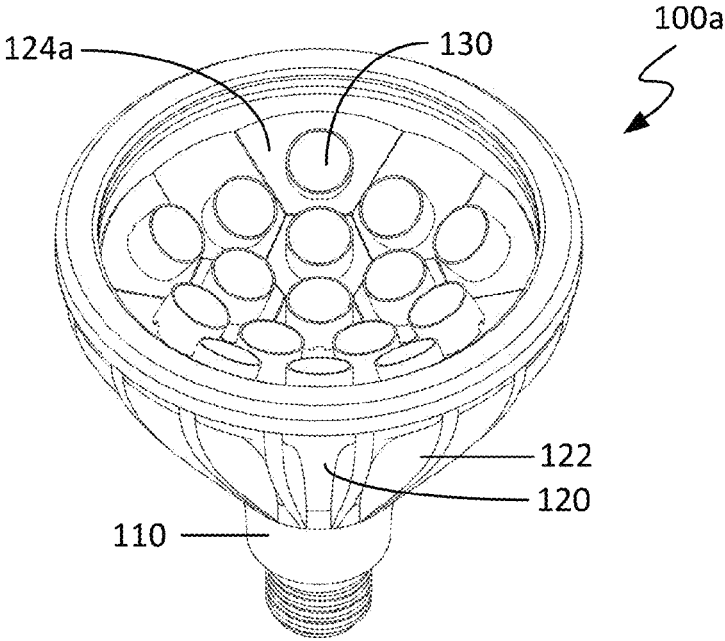

Figure 6

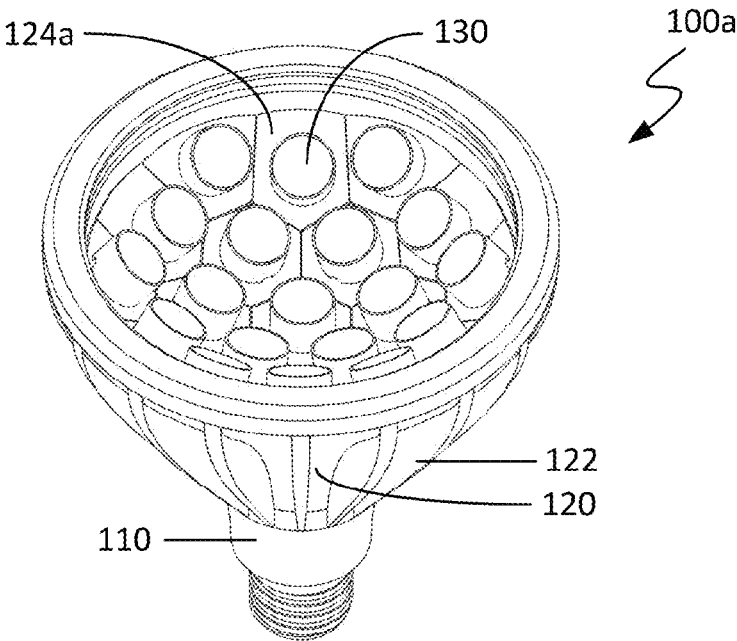

Figure 7A

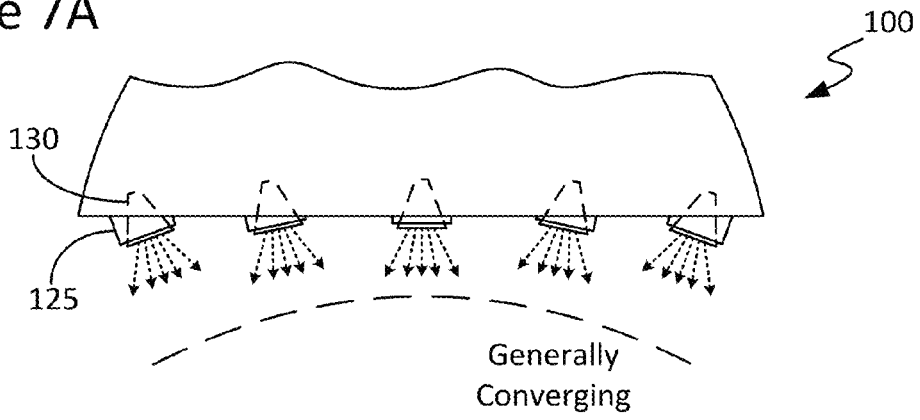

Figure 7B

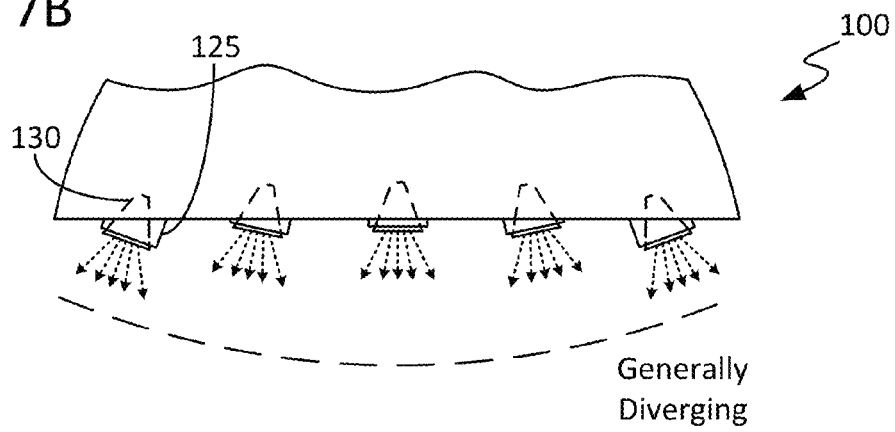

Figure 7C

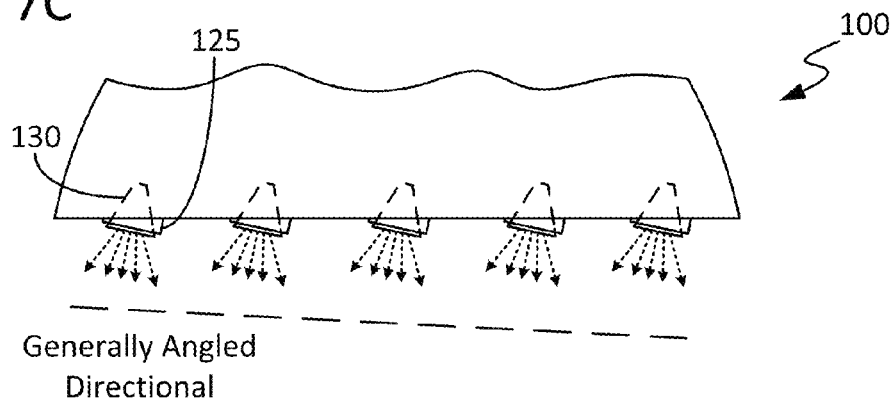

Figure 8

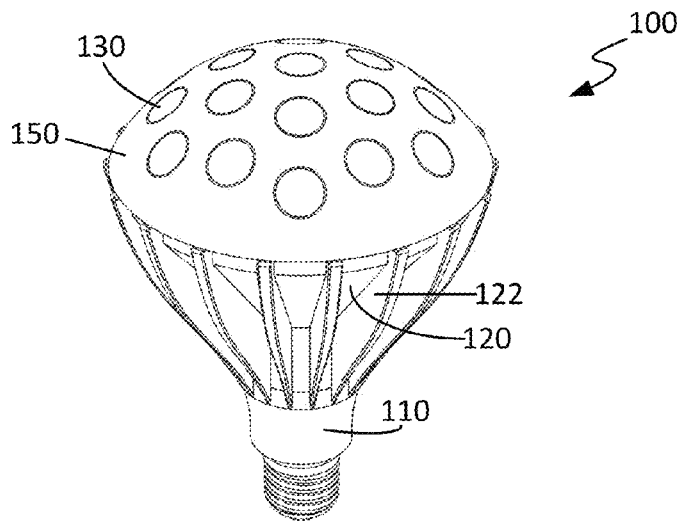

Figure 9A

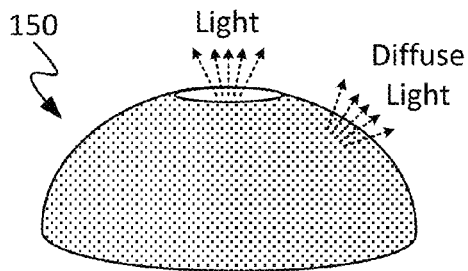

Figure 9B

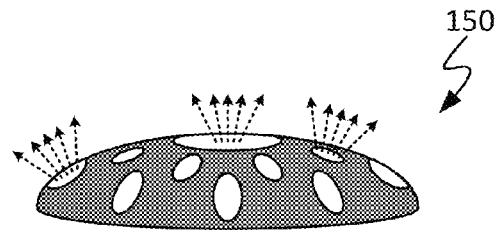

Figure 9C

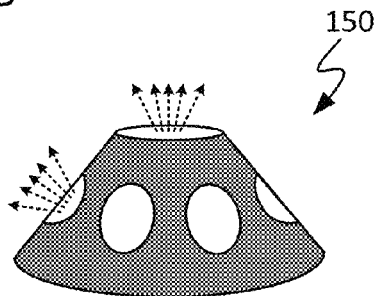

Figure 9D

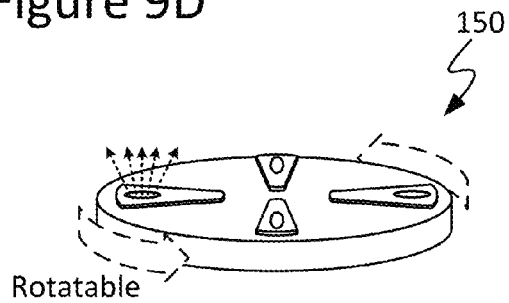

Figure 10

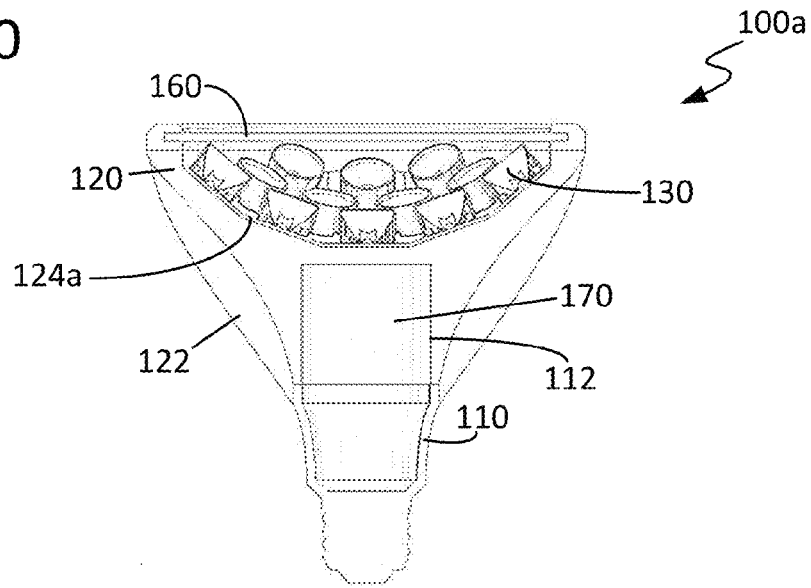

Figure 11A

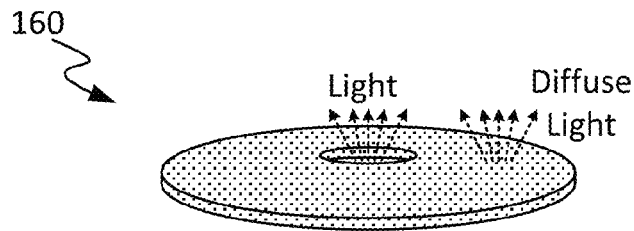

Figure 11B

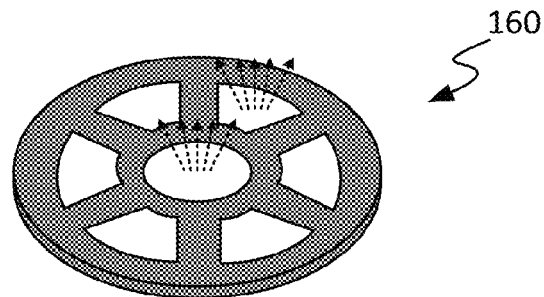

Figure 12A

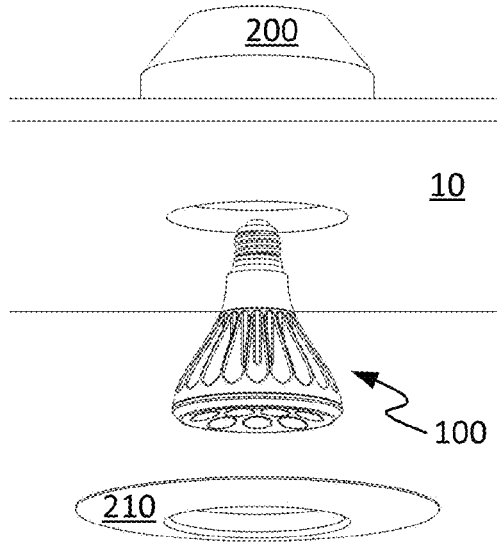

Figure 12B

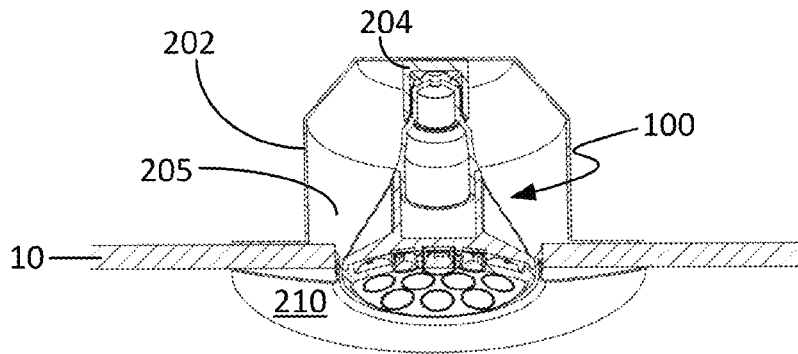

Figure 12C

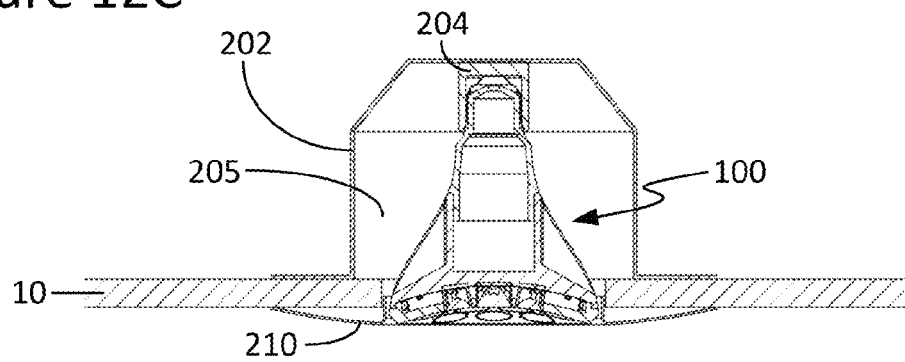

Figure 13A

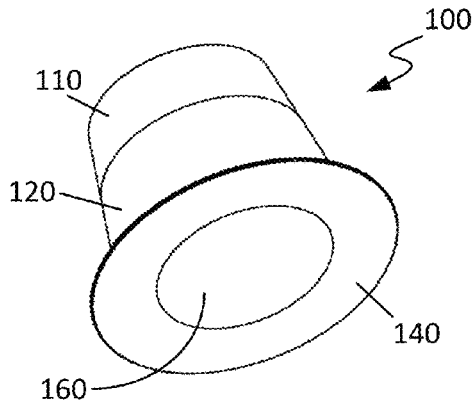

Figure 13B

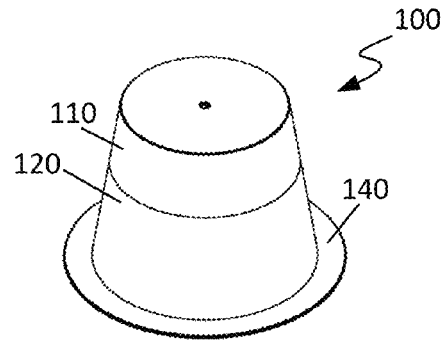

Figure 13C

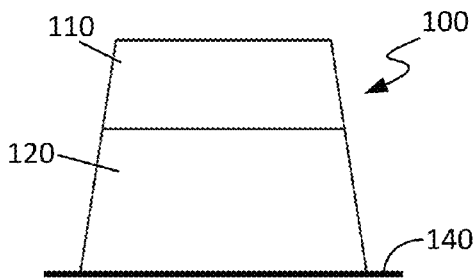

Figure 13D

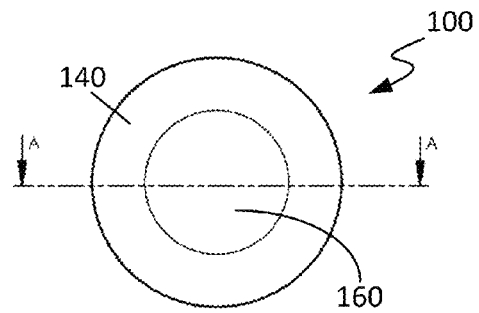

Figure 13E

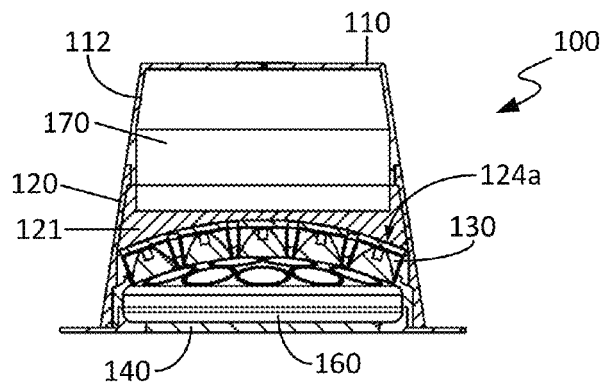

Figure 14

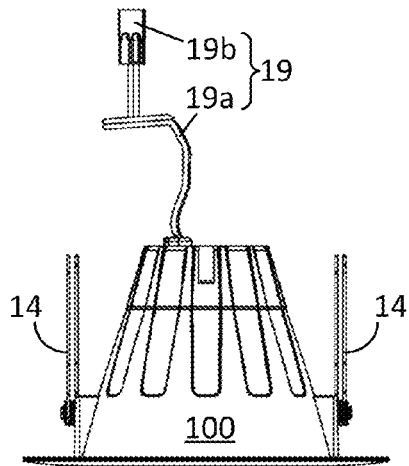

Figure 15

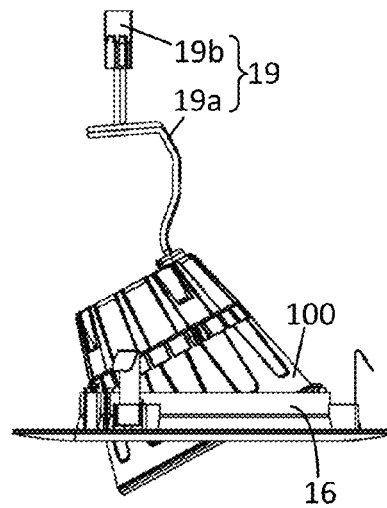

Figure 16A

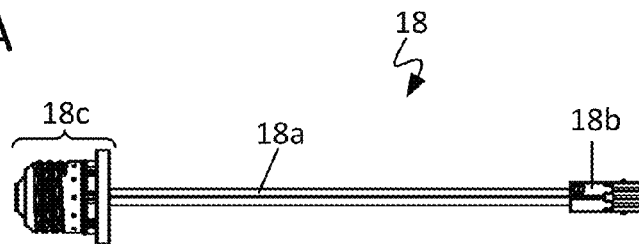

Figure 16B

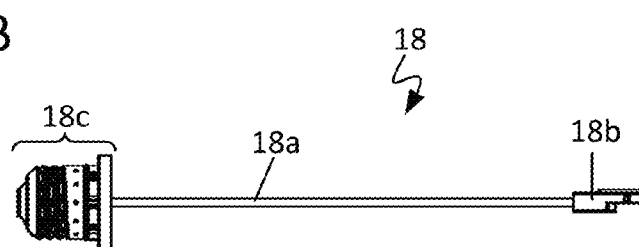

Figure 17A

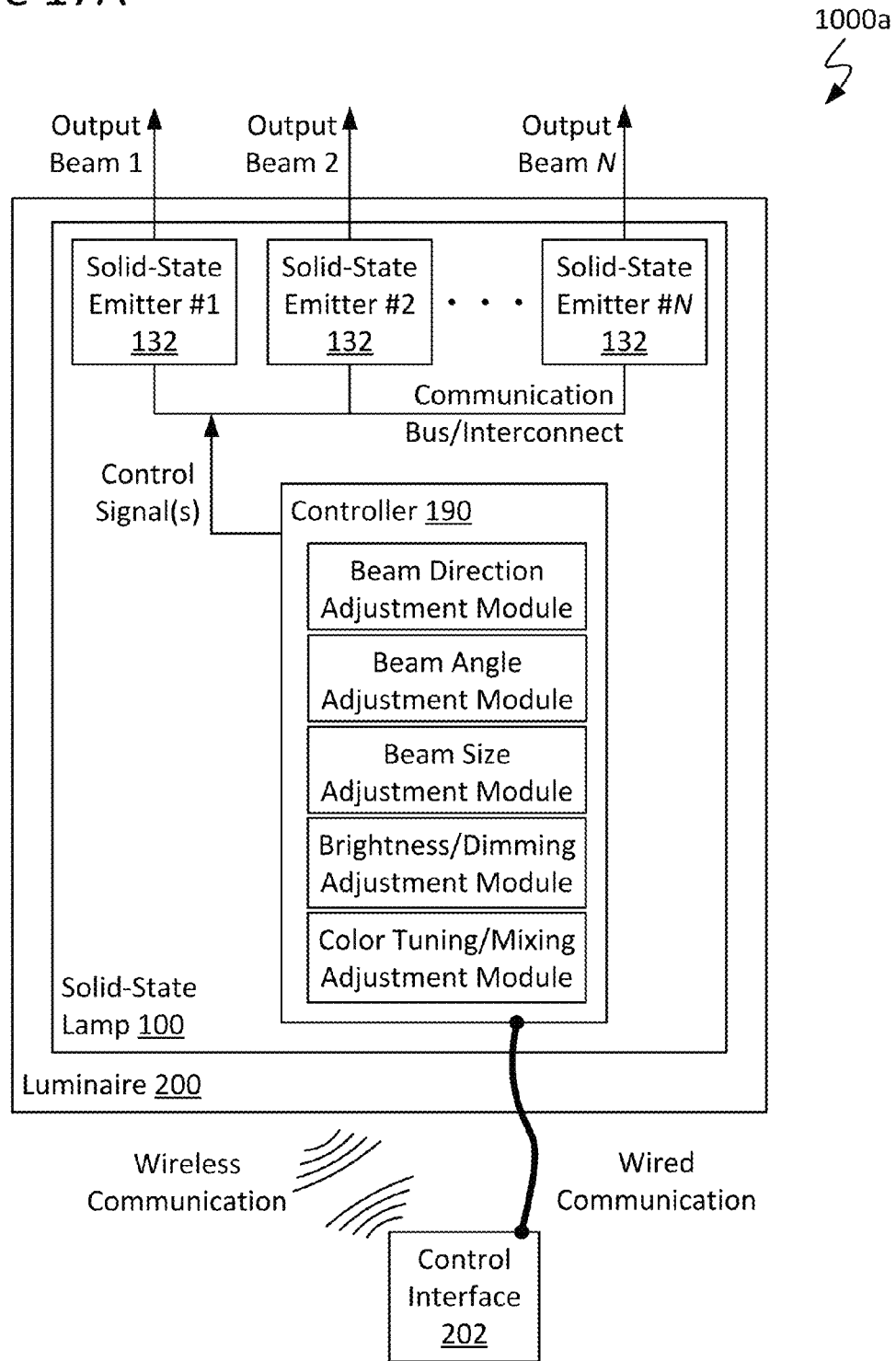
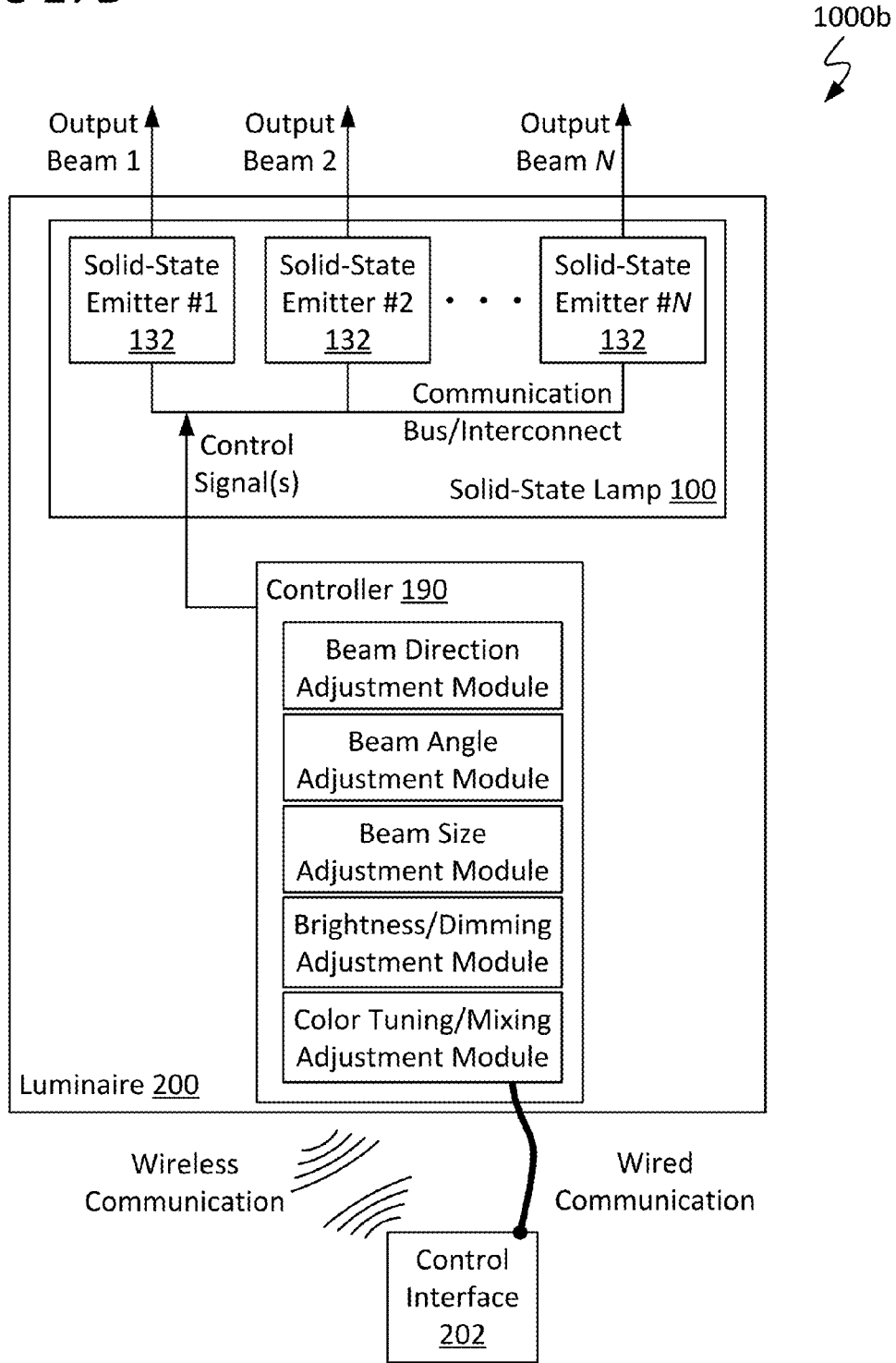

Figure 17B



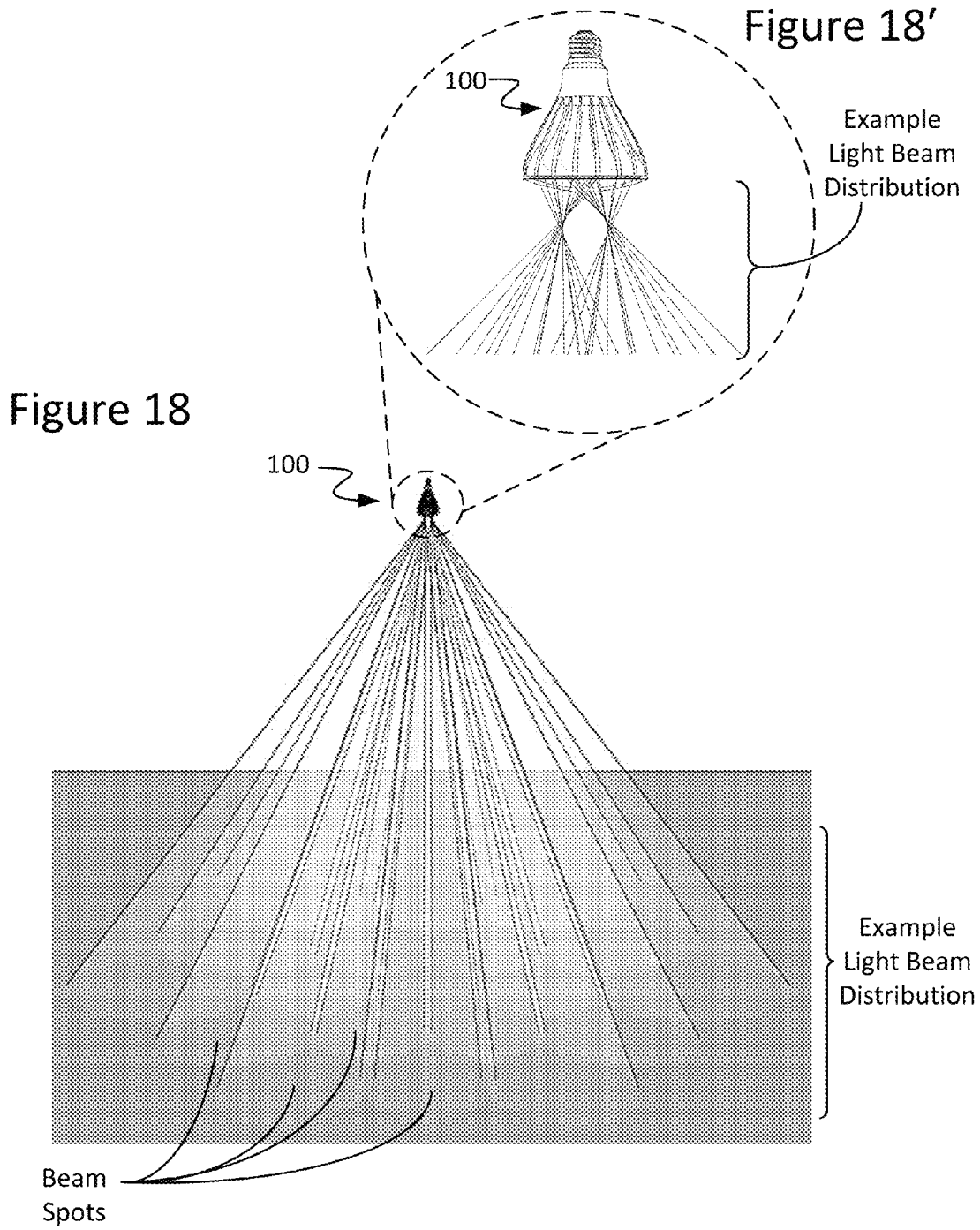

Figure 19A

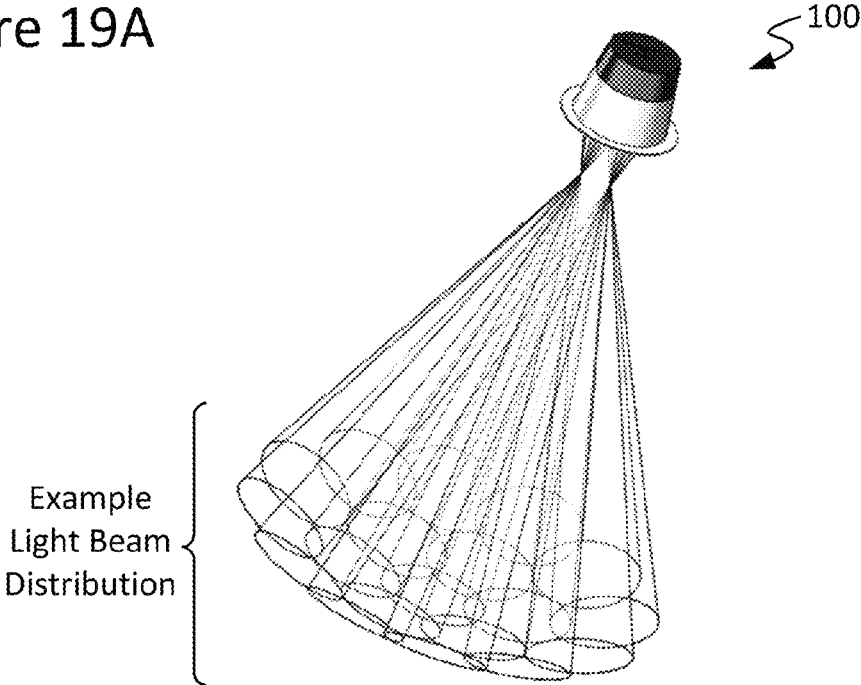

Figure 19B

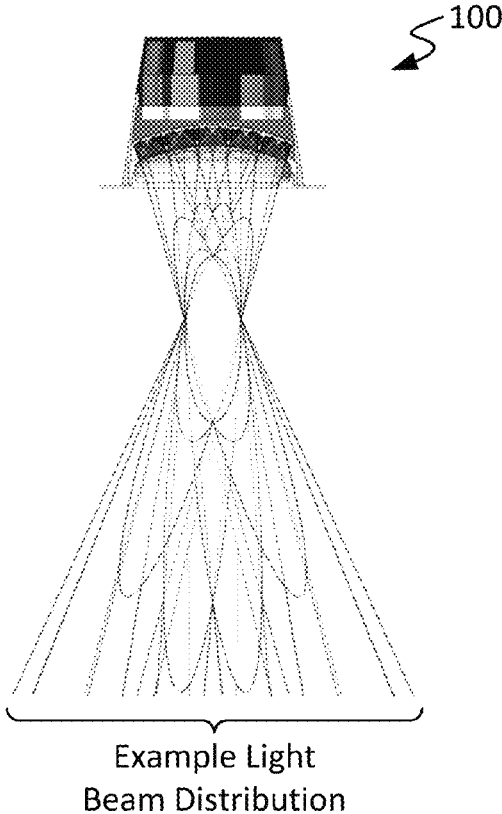
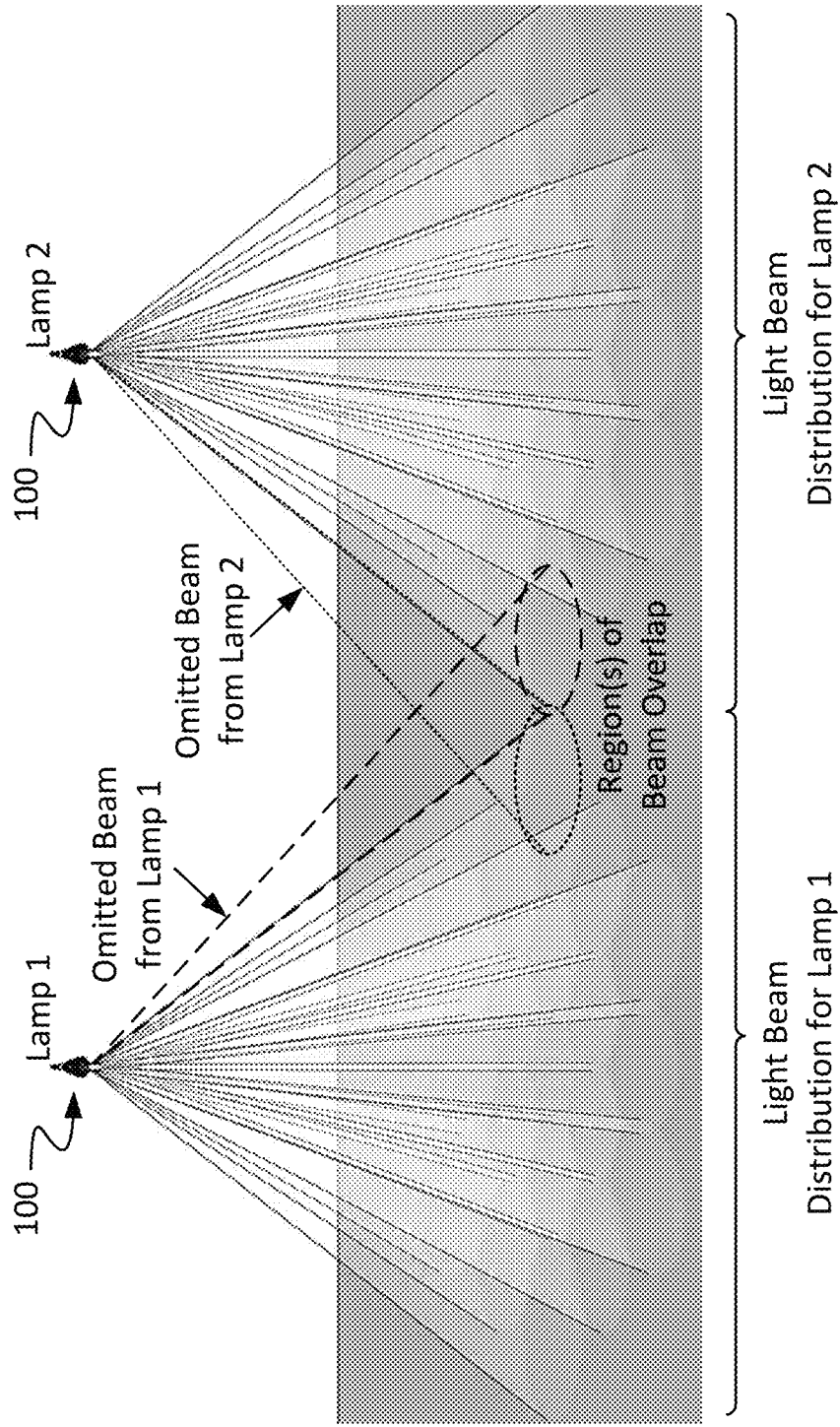

Figure 20



**SOLID-STATE LAMPS WITH
ELECTRONICALLY ADJUSTABLE LIGHT
BEAM DISTRIBUTION**

CROSS-REFERENCE TO RELATED
APPLICATIONS

This application is related to U.S. Non-Provisional patent application Ser. No. 14/531,375, filed on Nov. 3, 2014, U.S. Non-Provisional patent application Ser. No. 14/032,821, filed on Sep. 20, 2013, and U.S. Non-Provisional patent application Ser. No. 14/032,856, filed on Sep. 20, 2013, each of which is herein incorporated by reference in its entirety.

FIELD OF THE DISCLOSURE

The present disclosure relates to solid-state lighting (SSL) and more particularly to light-emitting diode (LED)-based lamps.

BACKGROUND

Traditional adjustable lighting fixtures, such as those utilized in theatrical lighting, employ mechanically adjustable lenses, track heads, gimbals, and other mechanical parts to adjust the angle and direction of the light output thereof. Mechanical adjustment of these components is normally provided by actuators, motors, or manual adjustment by a lighting technician. However, the cost of such designs is normally high given the complexity of the mechanical equipment required to provide the desired degree of adjustability. In addition, existing designs generally include relatively large components, making their form factors too large for retrofit applications.

BRIEF DESCRIPTION OF THE DRAWINGS

FIG. 1A is a perspective view of a solid-state lamp configured in accordance with an embodiment of the present disclosure.

FIG. 1B is a side view of the solid-state lamp of FIG. 1A.

FIG. 1C is a cross-sectional view of the solid-state lamp of FIG. 1B taken along line A-A therein.

FIG. 2A is a perspective view of a solid-state lamp configured in accordance with another embodiment of the present disclosure.

FIG. 2B is a side view of the solid-state lamp of FIG. 2A.

FIG. 2C is a cross-sectional view of the solid-state lamp of FIG. 2B taken along line A-A therein.

FIG. 3 is a cross-sectional view of a solid-state light source configured in accordance with an embodiment of the present disclosure.

FIG. 4A is a plan view of a solid-state lamp configured for retrofitting a MR16 socket/enclosure, in accordance with an example embodiment of the present disclosure.

FIG. 4B is a plan view of a solid-state lamp configured for retrofitting a MR16 socket/enclosure, in accordance with another example embodiment of the present disclosure.

FIG. 4C is a plan view of a solid-state lamp configured for retrofitting a PAR30 socket/enclosure, in accordance with another example embodiment of the present disclosure.

FIG. 5 is a perspective view of a concave solid-state lamp configured for retrofitting a PAR30 socket/enclosure, in accordance with another embodiment of the present disclosure.

FIG. 6 is a perspective view of a concave solid-state lamp configured for retrofitting a BR40 socket/enclosure, in accordance with another embodiment of the present disclosure.

FIGS. 7A-7C illustrate several example solid-state lamps including example arrangements of optional pre-positioning blocks, in accordance with some embodiments of the present disclosure.

FIG. 8 illustrates a solid-state lamp optionally including a cover portion, in accordance with an embodiment of the present disclosure.

FIG. 9A-9D illustrate several example cover portions configured in accordance with some embodiments of the present disclosure.

FIG. 10 illustrates a cross-sectional view of a solid-state lamp optionally including optics, in accordance with an embodiment of the present disclosure.

FIGS. 11A-11B illustrate several example optics configured in accordance with some embodiments of the present disclosure.

FIGS. 12A-12C illustrate installation of a solid-state lamp within an example luminaire, in accordance with some embodiments of the present disclosure.

FIG. 13A is a perspective view of a solid-state lamp configured in accordance with another embodiment of the present disclosure.

FIG. 13B is another perspective view of the solid-state lamp of FIG. 13A.

FIG. 13C is a side view of the solid-state lamp of FIG. 13A.

FIG. 13D is an end view of the solid-state lamp of FIG. 13A.

FIG. 13E is a cross-sectional view of the solid-state lamp of FIG. 13D taken along line A-A therein.

FIG. 14 is a side view of a solid-state lamp configured in accordance with another embodiment of the present disclosure.

FIG. 15 is a side view of a solid-state lamp configured in accordance with another embodiment of the present disclosure.

FIG. 16A is a top view of a power socket adapter for a solid-state lamp configured in accordance with an embodiment of the present disclosure.

FIG. 16B is a side view of the power socket adapter of FIG. 16A.

FIG. 17A is a block diagram of a lighting system configured in accordance with an embodiment of the present disclosure.

FIG. 17B is a block diagram of a lighting system configured in accordance with another embodiment of the present disclosure.

FIGS. 18 and 18' illustrate an example light beam distribution of a solid-state lamp configured in accordance with an embodiment of the present disclosure.

FIGS. 19A and 19B illustrate an example light beam distribution of a recessed can-type solid-state lamp configured in accordance with another embodiment of the present disclosure.

FIG. 20 illustrates example light beam distributions of neighboring solid-state lamps configured in accordance with an embodiment of the present disclosure.

These and other features of the present embodiments will be understood better by reading the following detailed description, taken together with the figures herein described. The accompanying drawings are not intended to be drawn to scale. In the drawings, each identical or nearly identical component that is illustrated in various figures may be

represented by a like numeral. For purposes of clarity, not every component may be labeled in every drawing.

DETAILED DESCRIPTION

Solid-state lamps having an electronically adjustable light beam distribution are disclosed. In accordance with some embodiments, a lamp configured as described herein includes a plurality of solid-state emitters mounted over a non-planar interior surface of the lamp. In accordance with some embodiments, a given emitter may be individually addressable and/or addressable in one or more groupings, as desired for a given target application or end-use. The interior mounting surface can be concave or convex, as desired, and may be of hemispherical or hyper-hemispherical geometry, among others, in accordance with some example embodiments. In some embodiments, the heat sink of the lamp may be configured to provide the interior mounting surface, whereas in some other embodiments, a separate mounting interface, such as a parabolic aluminized reflector (PAR), a bulged reflector (BR), or a multi-faceted reflector (MR), may be included to such end. Also, the lamp may include one or more focusing optics for modifying its output. In some cases, a lamp provided as described herein may be configured for retrofitting existing lighting structures. Numerous configurations and variations will be apparent in light of this disclosure.

General Overview

For adjusting light distribution, existing lighting designs rely upon mechanical movements provided using motors or other moving components manipulated by a user. However, the cost of such designs is normally high given the complexity of the mechanical equipment required to provide the desired degree of adjustability. In addition, existing designs generally include relatively large components, making their form factors too large for retrofit luminaire applications.

Thus, and in accordance with some embodiments of the present disclosure, solid-state lamps having an electronically adjustable light beam distribution are disclosed. In accordance with some embodiments, a lamp configured as described herein includes a plurality of solid-state emitters mounted over a non-planar interior surface of the lamp. In accordance with some embodiments, a given emitter may be individually addressable and/or addressable in one or more groupings, as desired for a given target application or end-use. The interior mounting surface can be concave or convex, as desired, and may be of hemispherical or hyper-hemispherical geometry, among others, in accordance with some example embodiments. In some embodiments, a portion of the heat sink of the lamp may be configured to serve as the interior mounting surface, whereas in some other embodiments, a separate mounting interface, such as a parabolic aluminized reflector (PAR), a bulged reflector (BR), or a multi-faceted reflector (MR), may be included to such end. Also, the lamp may include one or more focusing optics for modifying its output. In some cases, a lamp provided as described herein may be configured for retrofitting existing lighting structures.

In accordance with some embodiments, a lamp configured as described herein can be communicatively coupled with one or more controllers and driver circuitry that can be used to electronically control the output of the solid-state emitters individually and/or in conjunction with one another (e.g., as an array/grouping or partial array/grouping), thereby electronically controlling the output of the lamp as a whole. In some cases, a lamp provided as described herein may be configured for electronic adjustment, for example, of its

beam direction, beam angle, beam distribution, and/or beam diameter, thereby allowing for customizing the spot size, position, and/or distribution of light on a given surface of incidence. In some cases, a lamp configured as described herein may provide for electronic adjustment, for example, of its brightness (dimming) and/or color of light, thereby allowing for dimming and/or color mixing/tuning, as desired. In accordance with some embodiments, the plurality of pre-positioned, solid-state emitters of a lamp configured as described herein may be controlled individually to manipulate beam angle and distribution, for example, without the need for mechanically moving parts and physical access to the host socket. In a more general sense, and in accordance with an embodiment, the properties of the light output of a lamp configured as described herein may be adjusted electronically without need for mechanical movements, contrary to existing lighting systems.

In accordance with some embodiments, control of the emission of a lamp configured as described herein may be provided using any of a wide range of wired and/or wireless control interfaces, such as a switch array, a touch-sensitive surface or device, and/or a computer vision system (e.g., that is gesture-sensitive, activity-sensitive, and/or motion-sensitive, for example), to name a few. In some instances, a wireless software-based control interface may be utilized for intelligent control of light distribution, allowing a user to quickly and easily reconfigure the lighting in a given space, as desired.

As will be appreciated in light of this disclosure, a lamp configured as described herein may provide for flexible and easily adaptable lighting, capable of accommodating any of a wide range of lighting applications and contexts, in accordance with some embodiments. For example, some embodiments may provide for downlighting adaptable to small and large area tasks (e.g., high intensity with adjustable distribution and directional beams). Some embodiments may provide for accent lighting or area lighting of any of a wide variety of distributions (e.g., narrow, wide, asymmetric/tilted, Gaussian, batwing, or other specifically shaped beam distribution). By turning ON/OFF and/or dimming/brightening the intensity of various combinations of solid-state emitters of the lamp, the light beam output may be adjusted, for instance, to produce uniform illumination on a given surface, to fill a given space with light, or to generate any desired area lighting distributions. Numerous suitable uses and applications will be apparent in light of this disclosure.

In accordance with some embodiments, a lamp provided as described herein can be configured for installment or other operative coupling with a recessed light, a pendant light, a sconce, or the like which may be mounted, for example, on a ceiling, wall, floor, step, or other suitable surface, as will be apparent in light of this disclosure. In some other embodiments, a lamp provided as described herein can be configured for installment or other operative coupling with a free-standing lighting device, such as a desk lamp or torchière lamp. In some still other embodiments, a lamp provided as described herein may be configured for installment or other operative coupling with a fixture mounted, for example, on a drop ceiling tile (e.g., 2 ft.×2 ft., 2 ft.×4 ft., 4 ft.×4 ft., or larger) for installment in a drop ceiling grid. Numerous other suitable configurations will be apparent in light of this disclosure.

As will be further appreciated in light of this disclosure, a lamp configured as described herein may be considered, in a general sense, a robust, intelligent, multi-purpose lighting component capable of producing a highly adjustable light output without requiring mechanical movement of lighting

componentry. Some embodiments may provide for a greater level of light beam adjustability, for example, as compared to traditional lighting designs utilizing larger moving mechanical parts. Some embodiments may realize a reduction in cost, for example, as a result of the use of longer-lifespan solid-state devices and reduced installation, operation, and other labor costs. Furthermore, the scalability and orientation of a solid-state lamp configured as described herein may be varied, in accordance with some embodiments, to adapt to a specific lighting context or application (e.g., downward-facing, such as in a drop ceiling lighting fixture, a pendant lighting fixture, a desk light, etc.; upward-facing, such as in indirect lighting aimed at a ceiling). In accordance with some embodiments, a lamp configured as described herein may allow for great flexibility with respect to lighting direction and distribution in a relatively compact component for use in retrofitting existing lighting fixtures.

Structure and Operation

FIGS. 1A-1C illustrate several views of a solid-state lamp **100a** configured in accordance with an embodiment of the present disclosure. FIGS. 2A-2C illustrate several views of a solid-state lamp **100b** configured in accordance with another embodiment of the present disclosure. For consistency and ease of understanding of the present disclosure, solid-state lamps **100a** and **100b** hereinafter may be collectively referred to generally as a solid-state lamp **100**, except where separately enumerated. As discussed herein, the configuration (e.g., geometry, fitting size, light source arrangement, etc.) of a given lamp **100** may be customized, as desired for a given target application or end-use, and in accordance with some embodiments, may be compatible for retrofitting sockets/enclosures typically used in existing luminaire structures. Thus, in a general sense, lamp **100** may be considered a retrofit or other drop-in replacement lighting component, in accordance with some embodiments.

The base portion **110** of lamp **100** may be configured to engage a typical power socket and can have any of a wide range of configurations to that end. For instance, some example suitable configurations for base portion **110** include: a threaded lamp base including an electrical foot contact; a bi-pin, tri-pin, or other multi-pin lamp base; a twist-lock mount lamp base; and/or a bayonet connector lamp base. Also, base portion **110** may be of any standard and/or custom fitting size, as desired for a given target application or end-use. For example, in accordance with some embodiments, base portion **110** may be of a fitting size that is compatible for retrofitting sockets/enclosures typically used in luminaires, such as: MR16; PAR16; PAR20; PAR30; PAR38; BR30; BR40; and/or 4"-6" recessed kits. Other suitable configurations for base portion **110** will depend on a given application and will be apparent in light of this disclosure.

In some embodiments, base portion **110** optionally may have an internal cavity **112** formed therein. When included, internal cavity **112** may be configured, for example, to house electronic componentry/devices that may be associated with lamp **100**, and the particular dimensions of optional internal cavity **112** can be customized to such end. As discussed below, driver **170** of lamp **100**, for example, may be housed within internal cavity **112**, in accordance with some embodiments.

The heat sink portion **120** of lamp **100** may be configured to facilitate heat dissipation for the one or more solid-state light sources **130** (discussed below) thereof, and in some embodiments may include a plurality of fin-like features **122** to that end. In some cases, the fins **122** and heat sink portion **120** may be formed as a unitary component; that is, fins **122**

and heat sink portion **120** may be formed from a single (e.g., monolithic) piece of material to provide a single, continuous heat sink component. In some other cases, however, the fins **122** and heat sink portion **120** may be separate elements that are assembled with one another; that is, fins **122** and heat sink portion **120** may be attached to or otherwise assembled with one another using any suitable means, such as a snap-on fit, a friction fit, a screw fit, welding, adhesive, fastener(s), or any other suitable technique for joining fins **122** and heat sink portion **120**, as will be apparent in light of this disclosure. To facilitate heat dissipation, heat sink portion **120** may be constructed from any suitable thermally conductive material, such as, for example: aluminum (Al); copper (Cu); brass; steel; a composite and/or polymer (e.g., ceramics, plastics, etc.) doped with thermally conductive material; and/or a combination of any one or more thereof. Other suitable materials and configurations for heat sink portion **120** will depend on a given application and will be apparent in light of this disclosure.

In some cases, heat sink portion **120** and body portion **110** may be separate pieces that may be operatively coupled with one another in forming lamp **100**. That is, in some embodiments, body portion **110** and heat sink portion **120** may be attached to or otherwise assembled with one another using any of the example techniques/means discussed above, for instance, with respect to fins **122**. In some other cases, however, heat sink portion **120** and body portion **110** may be formed as a unitary component. That is, in some embodiments, body portion **110** and heat sink portion **120** may be formed from a single (e.g., monolithic) piece of material to provide a single, continuous component. Numerous suitable configurations will be apparent in light of this disclosure.

In accordance with some embodiments, a given lamp **100** may include one or more solid-state light sources **130** arranged therein. FIG. 3 is a cross-sectional view of a solid-state light source **130** configured in accordance with an embodiment of the present disclosure. A given solid-state light source **130** may include one or more solid-state emitters **132** configured to emit wavelength(s) from any spectral band (e.g., visible, infrared, ultraviolet, etc.), as desired for a given target application or end-use. In some embodiments, a given solid-state emitter **132** may be individually addressable. In some embodiments, a given solid-state emitter **132** may be addressable in one or more groupings. Some example suitable solid-state emitters **132** for use in lamp **100** include: a light-emitting diode (LED); an organic light-emitting diode (OLED); a polymer light-emitting diode (PLED); and/or any other suitable semiconductor light source, as will be apparent in light of this disclosure. In some embodiments, a given solid-state emitter **132** may be configured for emissions of a single correlated color temperature (CCT) (e.g., a white light-emitting semiconductor light source). In some other embodiments, however, a given solid-state emitter **132** may be configured for color-tunable emissions. For instance, a given solid-state emitter **132** may be a multi-color (e.g., bi-color, tri-color, etc.) semiconductor light source configured for RGB, RGBY, RGBW, WW, or other desired emissions. In some embodiments, a given solid-state emitter **132** may be configured as a high-brightness semiconductor light source. In some cases, a given solid-state emitter **132** may be provided with a combination of any one or more of the aforementioned example emissions capabilities. Other suitable configurations for the one or more solid-state emitters **132** of a given solid-state light source **130** of lamp **100** will depend on a given application and will be apparent in light of this disclosure.

The one or more solid-state emitters **132** of a given solid-state light source **130** can be packaged or non-packaged, as desired, and in some cases may be populated on a printed circuit board (PCB) **134** or other suitable intermediate/substrate. In some embodiments, all (or some sub-set) of the solid-state emitters **132** of a given solid-state light source **130** may have their own associated PCBs **134**. In some such cases, all (or some sub-set) of those PCBs **134** may be interconnected with one another using any suitable interconnection techniques (e.g., interconnecting wires), as will be apparent in light of this disclosure. Also, in accordance with some embodiments, all (or some sub-set) of those PCBs **134** may be arranged to conform to (or otherwise map) the contour of underlying mounting surface **124** (e.g., concave mounting surface **124a**; convex mounting surface **124b**), discussed below. In some embodiments, all (or some sub-set) of the solid-state emitters **132** of a given solid-state light source **130** may share a single PCB **134**. In some such cases, the shared PCB **134** may be folded, faceted, articulated, or otherwise configured to conform to (or otherwise generally map) the contour of underlying mounting surface **124** (e.g., concave mounting surface **124a**; convex mounting surface **124b**). Also, as will be appreciated in light of this disclosure, a given PCB **134** may include other componentry (e.g., resistors, transistors, integrated circuits, etc.) populated thereon in addition to one or more solid-state emitters **132**, in accordance with some embodiments. In some cases, the power and/or control connections for a given solid-state emitter **132** may be routed from a given PCB **134** to a driver **170** (and/or other devices/componentry) housed, for example, within internal cavity **112** of base portion **110**. Other suitable configurations for the one or more PCBs **134** of a given lamp **100** will depend on a given application and will be apparent in light of this disclosure.

As can be seen further from FIG. 3, a given solid-state light source **130** may include one or more optics **136**, in accordance with some embodiments. Optics **136** may be configured, in accordance with some embodiments, to transmit the one or more wavelengths of interest of the light (e.g., visible, ultraviolet, infrared, etc.) emitted by solid-state emitter(s) **132** optically coupled therewith. To that end, optics **136** may include an optical structure (e.g., a lens, window, dome, etc.) formed from any of a wide range of optical materials, such as, for example: a polymer, such as poly(methyl methacrylate) (PMMA) or polycarbonate; a ceramic, such as sapphire (Al₂O₃) or yttrium aluminum garnet (YAG); a glass; and/or a combination of any one or more thereof. In some instances, optics **136** may include optical features, such as, for example: an anti-reflective (AR) coating; a reflector; a diffuser; a polarizer; a brightness enhancer; and/or a phosphor material (e.g., which converts light received thereby to light of a different wavelength). The size, geometry, and/or optical transmission characteristics of optics **136** may be customized, as desired for a given target application or end-use.

In some embodiments, each solid-state light source **130** of lamp **100** may have its own optics **136** associated therewith, whereas in some other embodiments, multiple light sources **130** may share one or more optics **136**. In some embodiments, optics **136** may include one or more focusing optics. In some example cases, optics **136** may be a single optical structure (e.g., an injection-molded window, lens, dome, etc.) optically coupled with multiple solid-state light sources **130** of a lamp **100**. In some embodiments, the optics **136** of a given solid-state light source **130** may be attached to or

otherwise integrated with an optional cover portion **150** and/or (2) additional optional optics **160**, each discussed below.

In some cases, optics **136** may include electronically controllable componentry that may be used, in accordance with some embodiments, to modify the output of a host solid-state light source **130** (and thus modify the output of host lamp **100**). For example, optics **136** may include one or more electro-optic tunable lenses or other suitable focusing optics that can be electronically adjusted to vary the angle, direction, and/or size (among other attributes) of the light beam output by a given solid-state emitter **132**. In some other cases, optics **136** may include a Fresnel lens or other fixed optics, for example, to modify the output beam of a given solid-state light source **130**. Other suitable types and configurations for the optics **136** of a given solid-state light source **130** will depend on a given application and will be apparent in light of this disclosure.

In accordance with some embodiments, the light source(s) **130** of lamp **100** may be electronically coupled with a driver **170**. In some cases, driver **170** may be a multi-channel electronic driver configured, for example, for use in controlling one or more solid-state emitters **132** of a given lamp **100**. For instance, in some embodiments, driver **170** may be configured to control the ON/OFF state, dimming level, color of emissions, correlated color temperature (CCT), and/or color saturation of a given solid-state emitter **132** (or grouping of emitters **132**). To such ends, driver **170** may utilize any of a wide range of driving techniques, including, for example: (1) a pulse-width modulation (PWM) dimming protocol; (2) a current dimming protocol; (3) a triode for alternating current (TRIAC) dimming protocol; (4) a constant current reduction (CCR) dimming protocol; (5) a pulse-frequency modulation (PFM) dimming protocol; (6) a pulse-code modulation (PCM) dimming protocol; (7) a line voltage (mains) dimming protocol (e.g., dimmer is connected before input of driver **170** to adjust AC voltage to driver **170**); and/or any other suitable lighting control/driving technique, as will be apparent in light of this disclosure. As previously noted, driver **170** may be housed by lamp **100** within internal cavity **112** of base portion **110**, in some embodiments. Other suitable configurations for driver **170** will depend on a given application and will be apparent in light of this disclosure.

The quantity and arrangement of solid-state light sources **130** utilized in a given lamp **100** may be customized, as desired for a given target application or end-use, and in some instances may be selected based on the dimensions and/or geometry of the internal mounting surface(s) provided within lamp **100**. A given solid-state light source **130** may be mounted to mounting surface **124**, for example, via a thermally conductive adhesive or any other suitable coupling means, as will be apparent in light of this disclosure. In accordance with some embodiments, one or more solid-state light sources **130** can be arranged over a concave mounting surface **124a**, such as can be seen with respect to concave solid-state lamp **100a**, for example, shown in FIGS. 1A-1C. Conversely, in accordance with some other embodiments, one or more solid-state light sources **130** can be arranged over a convex mounting surface **124b**, such as can be seen with respect to convex solid-state lamp **100b**, for example, shown in FIGS. 2A-2C. For consistency and ease of understanding of the present disclosure, concave mounting surface **124a** and convex mounting surface **124b** hereinafter may be collectively referred to generally as mounting surface **124**, except where separately enumerated.

In accordance with some embodiments, the mounting surface **124** of lamp **100** may be provided, in part or in whole, by heat sink portion **120**. For instance, in some embodiments, an upper portion of heat sink portion **120** may be configured to provide a generally curved/non-planar concave mounting surface **124a** (e.g., such as can be seen in FIG. 1C). In some other embodiments, an upper portion of heat sink portion **120** may be configured to provide a generally curved/non-planar convex mounting surface **124b**.

It should be noted, however, that the present disclosure is not so limited, as in accordance with some other embodiments, the mounting surface **124** of lamp **100** may be provided, in part or in whole, by an optional mounting interface **121** disposed over and/or thermally coupled with heat sink portion **120** (e.g., such as can be seen in FIG. 2C). When included, optional mounting interface **121** may be constructed from any of the example materials discussed above, for instance, with respect to heat sink portion **120**. In an example case, optional mounting interface **121** may be a pre-formed metal sheet that is physically and/or thermally coupled with heat sink portion **120**. In some embodiments, mounting interface **121** may be a parabolic aluminized reflector (PAR). In some other embodiments, mounting interface **121** may be a bulged reflector (BR). In some still other embodiments, mounting interface **121** may be a multi-faceted reflector (MR). Other suitable configurations for optional mounting interface **121** will depend on a given application and will be apparent in light of this disclosure.

The geometry of mounting surface **124**, whether provided by heat sink portion **120** or an optional mounting interface **121**, may be customized, as desired for a given target application or end-use. In some embodiments, mounting surface **124** may be generally arcuate or sub-hemispherical in shape. In some other embodiments, mounting surface **124** may be generally hemispherical or oblate hemispherical in shape. In some other embodiments, mounting surface **124** may be hyper-hemispherical in shape. In some such cases, mounting of solid-state light sources **130** on a hyper-hemispherical mounting surface **124** may allow for directing light into higher angles and/or coverage of a larger space. In some instances, mounting surface **124** may provide a non-planar surface of generally smooth contour, while in some other instances, mounting surface **124** may provide a non-planar surface of generally non-smooth contour (e.g., faceted, angled, or otherwise articulated). Other suitable geometries for mounting surface **124** (e.g., concave mounting surface **124a** for lamp **100a**; convex mounting surface **124b** for lamp **100b**) will depend on a given application and will be apparent in light of this disclosure.

In some instances, the quantity and arrangement of solid-state light sources **130** may be selected, for example, based on the size of the socket and/or enclosure that is to receive lamp **100**. For instance, consider FIG. 4A, which is a plan view of a solid-state lamp **100** configured for retrofitting a MR16 socket/enclosure, in accordance with an example embodiment of the present disclosure. As can be seen in this depicted example case, the diameter of mounting surface **124** may be about 2 inches, the diameter of each solid-state light source **130** may be about $\frac{5}{8}$ (0.625) inch, and the distance from the center of a given solid-state light source **130** to the edge of mounting surface **124** may be about $\frac{3}{8}$ (0.375) inch.

FIG. 4B is a plan view of a solid-state lamp **100** configured for retrofitting a MR16 socket/enclosure, in accordance with another example embodiment of the present disclosure. As can be seen in this depicted example case, the diameter of mounting surface **124** may be about 2 inches, the diameter

of each solid-state light source **130** may be about $\frac{5}{8}$ (0.625) inch, and the distance from the center of a given solid-state light source **130** to the edge of mounting surface **124** may be about $\frac{5}{8}$ (0.625) inch.

FIG. 4C is a plan view of a solid-state lamp **100** configured for retrofitting a PAR30 socket/enclosure, in accordance with another example embodiment of the present disclosure. As can be seen in this depicted example case, the diameter of mounting surface **124** may be about $3\frac{3}{4}$ (3.75) inches, the diameter of each solid-state light source **130** may be about $\frac{5}{8}$ (0.625) inch, the radial distance of a first (inner) concentric arrangement of solid-state light sources **130** from the center of mounting surface **124** may be about $\frac{3}{4}$ (0.75) inch, and the radial distance of a second (outer) concentric arrangement of solid-state light source **130** from the center of mounting surface **124** may be about $1\frac{3}{8}$ (1.375) inch. Also, this example lamp **100** may include a medium screw base portion **110**, configured as typically done.

FIG. 5 is a perspective view of a concave solid-state lamp **100a** configured for retrofitting a PAR30 socket/enclosure, in accordance with another embodiment of the present disclosure. As can be seen in this depicted example case, the illustrated lamp **100a** includes sixteen (16) solid-state light sources **130** arranged over a concave mounting surface **124a** configured, in accordance with an embodiment, as a parabolic aluminized reflector (PAR). FIG. 6 is a perspective view of a concave solid-state lamp **100a** configured for retrofitting a BR40 socket/enclosure, in accordance with another embodiment of the present disclosure. As can be seen in this depicted example case, the illustrated lamp **100a** includes nineteen (19) solid-state light sources **130** arranged over a concave mounting surface **124a** configured, in accordance with an embodiment, as a bulged reflector (BR). In some cases, the PAR-type or BR-type concave mounting surface **124a** may be formed, at least in part, from heat sink portion **120**, whereas in some other cases, it may be formed, at least in part, from an optionally included mounting interface (e.g., such as a mounting interface **121**, discussed above). It should be noted, however, that the present disclosure is not so limited only to mounting surfaces **124** configured as a PAR or BR, as in accordance with some other embodiments, a given mounting surface **124** may be configured, for example, as a multi-faceted reflector (MR) or any other standard and/or custom reflector, as will be apparent in light of this disclosure. Also, the quantities and arrangements of solid-state light sources **130** of a given solid-state lamp **100** may be customized as desired for a given target application or end-use and are not intended to be limited only to the specific example configurations depicted in FIGS. 5 and 6. Furthermore, the base portion **110** may be customized as desired, and in some cases may be, for instance, a medium Edison-type screw base configured as typically done. Numerous configurations will be apparent in light of this disclosure.

FIGS. 7A-7C illustrate several example lamps **100** including example arrangements of optional pre-positioning blocks **125**, in accordance with some embodiments of the present disclosure. When optionally included, a given pre-positioning block **125** may be configured, for example, to facilitate directional aiming of a solid-state light source **130** mounted thereon. To that end, a given optional pre-positioning block **125** may be provided with any desired surface topography (e.g., stepped, curved, faceted, etc.) and may be oriented at any desired inclination/declination angle. Also, when included, a given pre-positioning block **125** may be physically and/or thermally coupled, for example, with the heat sink portion **120** of lamp **100**, in accordance with some

embodiments. Furthermore, a given pre-positioning block **125** may be constructed from any of the example materials discussed above, for instance, with respect to heat sink portion **120**.

The quantity and arrangement of pre-positioning blocks **125**, when optionally included, can be customized. For example, in some cases, a given lamp **100** optionally may include a converging arrangement of pre-positioning blocks **125**, such as is generally illustrated in FIG. 7A. In some other cases, a diverging arrangement of pre-positioning blocks **125** may be provided, such as is generally illustrated in FIG. 7B. In some still other cases, an offset (e.g., skewed or otherwise angled) arrangement pre-positioning block **125**, such as is generally illustrated in FIG. 7C. Other suitable configurations for a given optional pre-positioning block **125** will depend on a given application and will be apparent in light of this disclosure.

Returning to FIGS. 1A-1C and 2A-2C, lamp **100** optionally may include a face plate portion **140**, in accordance with some embodiments. When included, optional face plate portion **140** may be constructed from any of the example materials discussed above, for instance, with respect to heat sink portion **120** and may be configured to interface with one or more solid-state light sources **130**, as typically done. In some embodiments, face plate portion **140** may be configured with a contour that is substantially similar to that of underlying mounting surface **124**. For instance, in some embodiments, face plate portion **140** may have a generally concave contour to complement an underlying concave mounting surface **124a**, such as can be seen with lamp **100a** in FIG. 1A. In some other embodiments, however, face plate portion **140** may have a generally convex contour to complement an underlying convex mounting surface **124b**, such as can be seen with lamp **100b** in FIG. 2A. In some still other embodiments, face plate portion **140** may be provided with a custom contour or a given degree of planarity, as desired for a given target application or end-use. Numerous suitable configurations will be apparent in light of this disclosure.

FIG. 8 illustrates a lamp **100** optionally including a cover portion **150**, in accordance with an embodiment of the present disclosure. Optional cover portion **150** may have any of a wide range of configurations. For instance, optional cover portion **150** may be constructed from any suitable material (e.g., plastic, acrylic, polycarbonate, etc.) having any desired degree of optical transparency, as will be apparent in light of this disclosure. Also, the size and/or geometry of cover portion **150** may be customized. For example, consider FIG. 9A-9D, which illustrate several example cover portions **150** configured in accordance with some embodiments of the present disclosure. In some embodiments, cover portion **150** may be generally dome-shaped or cone-shaped. In some embodiments, cover portion **150** may include one or more openings, of any desired dimensions and geometry, through which light may pass freely. In some embodiments, the body of cover portion **150** may be formed from a material that facilitates diffusion of light passing therethrough. In some embodiments, cover portion **150** may be configured to rotate partially and/or fully in one or more directions. Numerous suitable configurations for optional cover portion **150** will be apparent in light of this disclosure.

FIG. 10 illustrates a cross-sectional view of a concave lamp **100a** optionally including optics **160**, in accordance with an embodiment of the present disclosure. It should be noted, however, that the present disclosure is not so limited to inclusion of optional optics **160** only in the context of concave lamp **100a**, as in accordance with some other embodiments, a convex lamp **100b** optionally may be con-

figured to host one or more optics **160**. When included, optics **160** may be configured, in accordance with some embodiments, to transmit the one or more wavelengths of interest of the light (e.g., visible, ultraviolet, infrared, etc.) emitted by associated solid-state light source(s) **130**. To that end, optics **160** may include an optical structure (e.g., a lens, window, dome, etc.) formed from any of the example materials discussed above, for instance, with respect to optics **136**. In some instances, optics **160** may include optical features, such as, for example: an anti-reflective (AR) coating; a reflector; a diffuser; a polarizer; a brightness enhancer; and/or a phosphor material (e.g., which converts light received thereby to light of a different wavelength). In some embodiments, optics **160** may include one or more focusing optics. In some embodiments, lamp **100** may be configured such that one or more of the light beams produced by the solid-state light source(s) **130** of lamp **100** pass through a focal point generally located within optics **160**. In some cases, optics **160** may include electronically controllable componentry that may be used, in accordance with some embodiments, to modify the output of the solid-state light source(s) **130** of a given lamp **100**. For example, optics **160** may include one or more electro-optic tunable lenses or other suitable focusing optics that can be electronically adjusted to vary the angle, direction, and/or size (among other attributes) of the light beam output by a given solid-state light source **130**. In some cases, such electro-optic tunable componentry may be utilized to narrow or widen accumulated light distribution, thereby contributing to varying the beam angle, beam direction, beam distribution, and/or beam size (among other attributes) of the light beam output by lamp **100**. In some other cases, optics **160** may include a Fresnel lens or other fixed optics, for example, to modify the output beam of a given solid-state light source **130**.

The size, geometry, and transparency of optics **160** may be customized, as desired for a given target application or end-use. For example, consider FIGS. 11A-11B, which illustrate several example optics **160** configured in accordance with some embodiments of the present disclosure. In some embodiments, optics **160** may be generally planar or otherwise disc-shaped. In some embodiments, optics **160** may include one or more openings, of any desired dimensions and geometry, through which light may pass freely. In some embodiments, optics **160** may be formed from a material that facilitates diffusion of light passing therethrough. In some embodiments, optics **160** may be configured to rotate partially and/or fully in one or more directions. Other suitable types and configurations for the optics **160** that optionally may be hosted by lamp **100** will depend on a given application and will be apparent in light of this disclosure.

As will be appreciated in light of this disclosure, a given solid-state lamp **100** also may include or otherwise be operatively coupled with other circuitry/componentry, for example, which may be used in solid-state lamps and luminaires. For instance, lamp **100** may be configured to host or otherwise be operatively coupled with any of a wide range of electronic components, such as: (1) power conversion circuitry (e.g., electrical ballast circuitry to convert an AC signal into a DC signal at a desired current and voltage to power a given solid-state light source **130**); (2) constant current/voltage driver componentry; (3) transmitter and/or receiver (e.g., transceiver) componentry; and/or (4) internal processing componentry. When included, such componentry may be mounted, for example, on one or more driver **170**

13

boards and housed within lamp **100** (e.g., within internal cavity **112** of base portion **110**), in accordance with some embodiments.

Example Installations

As previously discussed, solid-state lamp **100** may be configured, in accordance with some embodiments, for retrofitting sockets/enclosures typically used in existing luminaire structures. Thus, in a general sense, solid-state lamp **100** may be considered a retrofit or other drop-in replacement lighting component for use in existing lighting infrastructure, in accordance with some embodiments.

FIGS. **12A-12C** illustrate installation of a solid-state lamp **100** within an example luminaire **200**, in accordance with some embodiments of the present disclosure. As can be seen from these figures, example luminaire **200** includes a housing **202** having a hollow space therein which defines a plenum **205** and a socket **204** disposed therein. Socket **204** may be of any standard and/or custom fitting size, as desired for a given target application or end-use, and lamp **100** may be configured to draw power from socket **204**, as typically done. In accordance with some embodiments, luminaire **200** may be configured to receive a lamp **100** of any of a wide range of formats, including, for example: MR16; PAR16; PAR20; PAR30; PAR38; BR30; BR40; and/or 4"-6" recessed kits. In some cases, a bezel **210** (e.g., a trim, collar, baffle, etc.) optionally may be utilized with luminaire **200**.

In some embodiments, luminaire **200** may be configured to be mounted or otherwise fixed to a mounting surface **10** in a temporary or permanent manner. In some cases, luminaire **200** may be configured to be mounted as a recessed lighting fixture (e.g., as generally illustrated in FIGS. **12A-12C**), whereas in some other cases, luminaire **200** may be configured as a pendant-type fixture, a sconce-type fixture, or other lighting fixture which may be suspended or otherwise extended from a given mounting surface **10**. Some example suitable mounting surfaces **10** for luminaire **200** include ceilings, walls, floors, and/or steps. In some instances, mounting surface **10** may be a drop ceiling tile (e.g., having an area of about 2 ft.×2 ft., 2 ft.×4 ft., 4 ft.×4 ft., etc.) for installment in a drop ceiling grid. However, it should be noted that luminaire **200** need not be configured to be mounted on a mounting surface **10**, as in some other embodiments it may be configured as a free-standing or otherwise portable lighting device, such as a desk lamp or a torchière lamp, for example. Numerous suitable configurations for luminaire **200** will be apparent in light of this disclosure.

FIGS. **13A-13E** illustrate several views of a solid-state lamp **100** configured in accordance with another embodiment of the present disclosure. As can be seen here, lamp **100** can be configured as a recessed can-style lamp that may be installed in any standard and/or custom recessed lighting housing, including, for example, an insulation contact (IC) housing, a non-IC housing, and/or an airtight (AT) housing. The one or more solid-state light sources **130** may be arranged over a concave mounting surface **124a** (e.g., as generally shown in FIG. **13E**) or may be arranged over a convex mounting surface **124b**, as desired for a given target application or end-use. Mounting surface **124** may be provided, in part or in whole, by heat sink portion **120** and/or an optional mounting interface **121**, in accordance with some embodiments. Optional optics **160** may be included, in some instances.

FIG. **14** illustrates a side view of a solid-state lamp **100** configured in accordance with another embodiment of the present disclosure. As can be seen here, lamp **100** optionally may be coupled with an adjustable gimbal mount **14**. Gimbal

14

mount **14** may be configured, in accordance with some embodiments, to allow lamp **100**: (1) to be adjusted in angle (e.g., pointing direction); and/or (2) to rotate partially and/or fully in one or more directions (e.g., with respect to a given mounting surface **10**). Other suitable configurations for optional gimbal mount **14** will depend on a given application and will be apparent in light of this disclosure.

FIG. **15** illustrates a side view of a solid-state lamp **100** configured in accordance with another embodiment of the present disclosure. As can be seen here, lamp **100** optionally may be coupled with an adapter **16** to facilitate retrofitting within a given luminaire **200**, in some instances. In accordance with some embodiments, adapter **16** may be configured to be inserted within a given luminaire **200** to facilitate secure installation of a given lamp **100** therein. In some instances, adapter **16** may be configured to permit a lamp **100** to be adjusted in angle and/or to rotate within a given luminaire **200**, as desired for a given target application or end-use. Optional adapter **16** may be formed from any of the example materials discussed above, for instance, with respect to heat sink portion **120**, in accordance with some embodiments. The geometry and size of optional adapter **16** may be customized, as desired for a given target application or end-use.

As can be seen from FIGS. **14** and **15**, lamp **100** may be provided with a power cable **19**, in some embodiments. When provided, power cable **19** may include a wire portion **19a** and a connector portion **19b**. Wire portion **19a** may be configured as typically done, and any standard and/or custom connector (e.g., push wire; blade; ring terminal; spade terminal; soldered; crimp-on; etc.) may be utilized as connector portion **19b**, in accordance with some embodiments. When coupled with a power source, power cable **19** may serve to deliver power to lamp **100** for operation thereof, in accordance with some embodiments.

FIGS. **16A-16B** illustrate several views of an optional power socket adapter **18** configured in accordance with an embodiment of the present disclosure. As can be seen, optional power socket adapter **18** may include a wire portion **18a**, a connector portion **18b**, and a socket portion **18c**. Wire portion **18a** may be configured as typically done, and any standard and/or custom connector (e.g., push wire; blade; ring terminal; spade terminal; soldered; crimp-on; etc.) may be utilized as connector portion **18b**, in accordance with some embodiments. Connector portion **18b** may be configured, in some embodiments, to electronically couple with a correspondingly configured connector portion **19b** of a power cable **19**. Socket portion **18c** may be configured, in accordance with some embodiments, to electronically couple with a standard and/or custom power socket. As will be appreciated in light of this disclosure, socket portion **18c** may have any of the example configurations (e.g., contact type, fitting size, etc.) discussed above, for instance, with respect to base portion **110**, in accordance with some embodiments. When coupled with a power socket, power socket adapter **18** and power cable **19** may serve to deliver power to lamp **100** for operation thereof, in accordance with some embodiments.

Output Control

As previously noted, the solid-state emitters **132** of lamp **100** may be individually addressable and/or addressable in one or more groupings, and thus can be electronically controlled individually and/or in conjunction with one another (e.g., as one or more groupings of emitters **132**), for example, to provide highly adjustable light emissions from lamp **100**, in accordance with some embodiments. To that end, lamp **100** may include or otherwise be communica-

tively coupled with one or more controllers **190**, in accordance with some embodiments.

For example, consider FIG. **17A**, which is a block diagram of a lighting system **1000a** configured in accordance with an embodiment of the present disclosure. Here, a controller **190** is located in lamp **100** and operatively coupled (e.g., by a communication bus/interconnect) with the solid-state emitters **132** (1-N) of lamp **100**. In some instances, a given controller **190** of solid-state lamp **100** may be populated, for example, on one or more PCBs **134**. In this example case, controller **190** may output a control signal to any one or more of the solid-state emitters **132** and may do so, for example, based on wired and/or wireless input received from one or more control interfaces **202**, discussed below. As a result, lamp **100** may be controlled in such a manner as to output any number of output beams (1-N), which may be varied in beam direction, beam angle, beam size, beam distribution, brightness/dimness, and/or color, as desired for a given target application or end-use.

However, the present disclosure is not so limited. For instance, consider FIG. **17B**, which is a block diagram of a lighting system **1000b** configured in accordance with another embodiment of the present disclosure. Here, a controller **190** is located on-board luminaire **200** and operatively coupled (e.g., by a communication bus/interconnect) with the solid-state emitters **132** (1-N) of lamp **100**. In this example case, a given controller **190** of solid-state lamp **100** may output a control signal to any one or more of the solid-state emitters **132** and may do so, for example, based on wired and/or wireless input received from one or more control interfaces **202**, discussed below. As a result, lamp **100** may be controlled in such a manner as to output any number of output beams (1-N), which may be varied in beam direction, beam angle, beam size, beam distribution, brightness/dimness, and/or color, as desired for a given target application or end-use.

In accordance with some embodiments, a given controller **190** may host one or more lighting control modules and can be programmed or otherwise configured to output one or more control signals, for example, to adjust the operation of: (1) the one or more solid-state emitters **132** of a given solid-state lamp **100**; (2) the optics **136** of a given solid-state light source **130**; and/or (3) the optics **160** of a given solid-state lamp **100**, when optionally included. For example, in some cases, a given controller **190** may be configured to output a control signal to control whether the beam is ON/OFF, as well as control the beam direction, beam angle, beam distribution, and/or beam diameter of the light emitted by a given solid-state light source **130**. In some instances, a given controller **190** may be configured to output a control signal to control the intensity/brightness (e.g., dimming, brightening) of the light emitted by a given solid-state emitter **132**. In some cases, a given controller **190** may be configured to output a control signal to control the color (e.g., mixing; tuning) of the light emitted by a given solid-state emitter **132**. Thus, if a given solid-state lamp **100** includes two or more solid-state emitters **132** configured to emit light having different wavelengths, the control signal may be used to adjust the relative brightness of the different solid-state emitters **132** in order to change the mixed color output by that solid-state lamp **100**. In some instances in which a given solid-state light source **130** is configured for multi-colored emissions, such a source **130** may be electronically controlled, in accordance with some embodiments, so as to adjust the color of light distributed at different angles and/or directions.

In accordance with some embodiments, a given controller **190** may utilize any of a wide range of wired and/or wireless digital communications protocols, including, for example: (1) a digital multiplexer (DMX) interface protocol; (2) a Wi-Fi protocol; (3) a Bluetooth protocol; (4) a digital addressable lighting interface (DALI) protocol; (5) a ZigBee protocol; (6) a KNX protocol; (7) an EnOcean protocol; (8) a TransferJet protocol; (9) an ultra-wideband (UWB) protocol; (10) a WiMAX protocol; (11) a high performance radio metropolitan area network (HiperMAN) protocol; (12) an infrared data association (IrDA) protocol; (13) a Li-Fi protocol; (14) an IPv6 over low power wireless personal area network (6LoWPAN) protocol; (15) a MyriaNed protocol; (16) a WirelessHART protocol; (17) a DASH7 protocol; (18) a near field communication (NFC) protocol; (19) a Wavenis protocol; (20) a RuBee protocol; (21) a Z-Wave protocol; (22) an Insteon protocol; (23) a ONE-NET protocol; (24) an X10 protocol; and/or (25) any other suitable communications protocol, wired and/or wireless, as will be apparent in light of this disclosure. In some still other cases, a given controller **190** may be configured as a terminal block or other pass-through such that a given control interface **202** (discussed below) is effectively coupled directly with the individual solid-state emitters **132** of lamp **100**. Numerous suitable configurations will be apparent in light of this disclosure.

In accordance with some embodiments, the solid-state light sources **130** may be mounted over mounting surface **124** of lamp **100** such that their concave orientation (e.g., for a concave mounting surface **124a**) and/or convex orientation (e.g., for a convex mounting surface **124b**) provides a given desired beam distribution from lamp **100**. For instance, consider FIGS. **18** and **18'**, which illustrate an example light beam distribution of a solid-state lamp **100** configured in accordance with an embodiment of the present disclosure. Furthermore, consider FIGS. **19A-19B**, which illustrate an example light beam distribution of a recessed can-type solid-state lamp **100** configured in accordance with another embodiment of the present disclosure. As previously discussed, mounting surface **124** may be provided, in part or in whole, by heat sink portion **120** and/or an optional mounting interface **121**, in accordance with some embodiments.

Control of the solid-state light sources **130** of lamp **100** may be provided using any of a wide range of wired and/or wireless control interfaces **202**. In accordance with some embodiments, a given control interface **202** may include: (1) a physical control layer; and/or (2) a software control layer. The physical control layer may include, for instance, one or more switches (e.g., a sliding switch, a rotary switch, a toggle switch, a push-button switch, or any other suitable switch, as will be apparent in light of this disclosure) configured for use in controlling solid-state emitters **132** of lamp **100** individually and/or in conjunction with one another (e.g., as one or more groupings of emitters **132**). In some instances, one or more switches may be operatively coupled with a given controller **190**, which in turn interprets the switch input and distributes the desired control signal(s) to one or more of the solid-state emitters **132** of a lamp **100**. In some other instances, a given switch may be operatively coupled directly with one or more solid-state emitters **132** to control them directly. In some embodiments, the physical control layer may include one or more switches configured for activating pre-programmed lighting patterns/scenes using a given lamp **100**. Other suitable configurations for the physical control layer of a given control interface **202** will depend on a given application and will be apparent in light of this disclosure.

The software control layer of a given control interface 202 may be configured, for instance, for use in controlling solid-state emitters 132 of lamp 100 individually and/or in conjunction with one another (e.g., as one or more groupings of emitters 132). In accordance with some embodiments, the software control layer may be configured to customize the lighting distribution in a given space, for example, by intelligently controlling the solid-state emitters 132 of a lamp 100. For instance, the software control layer may be configured, in some embodiments, to intelligently determine how to dim the output level of one or more of the individual solid-state emitters 132 of a lamp 100 to achieve a given brightness and/or color. In some embodiments, the software control layer may be configured to program lighting patterns/scenes. In some instances, if lamp 100 includes on-board memory, for example, a programmed lighting pattern/scene may be saved and accessed through the software control layer and/or physical control layer of control interface 202. In an example case, a given lighting pattern/scene may be accessed, for instance, as a default setting/configuration whenever lamp 100 is turned ON.

In some cases, neighboring lamps 100 may be installed or otherwise positioned such that their respective beam distributions would overlap, at least to some degree. For instance, consider FIG. 20, which illustrates example light beam distributions of neighboring solid-state lamps 100 configured in accordance with an embodiment of the present disclosure. As can be seen in this example case, a first lamp 100 (Lamp 1) is configured to output a first beam distribution, and a neighboring lamp 100 (Lamp 2) is configured to output a second beam distribution that would overlap, at least in part, with that of Lamp 1. As will be appreciated in light of this disclosure, it may be desirable, in some instances, to prevent or otherwise reduce such beam overlap (e.g., to improve output efficiency for the lamps 100 of interest). To that end, the software control layer may be configured, in accordance with some embodiments, to determine how the output beams of neighboring lamps 100 would overlap and to determine how to manipulate the beam distribution of a given lamp 100 to achieve the illumination desired. In accordance with some embodiments, the software control layer may determine which individual solid-state light sources 130 of those lamps 100 of interest are optimally (or otherwise preferably) used in lighting a given space.

Thus, and in accordance with some embodiments, the software control layer of a given control interface 202 may control the output so as to prevent or otherwise reduce beam overlap between the neighboring lamps 100. In some cases, control interface 202 may be configured to ensure that neighboring lamps 100 omit one or more output beams that would overlap undesirably. The would-be beam overlap of neighboring lamps 100 may be determined, in some embodiments, by the software control layer of a given control interface 202 using any of wide range of data, such as: the mounting location of the lamps 100 of interest; the separation distance and/or angle of the neighboring lamps 100 of interest; the distance and/or angle between a lamp 100 of interest and the surface of incidence for its output; and/or a combination of any one or more thereof. In some instances, such information may be programmed into or otherwise native to a given lamp 100, whereas in some other instances, control interface 202 may be configured to obtain such information, automatically and/or upon user instruction/command. In accordance with some embodiments, the solid-state light sources 130 of neighboring lamps 100 may be manipulated to provide seamless, but not overlapping output

beam distributions. It should be noted, however, that the present disclosure is not so limited only to prevention of output overlap, as in accordance with some embodiments, some degree of overlapping of the output of neighboring lamps 100 may be intentionally provided, for example, to provide for color tuning. Other suitable configurations for the software control layer of a given control interface 202 will depend on a given application and will be apparent in light of this disclosure.

In some embodiments, a touch-sensitive device or surface, such as a touchpad or other device with a touch-based user interface (UI), may be utilized in controlling the solid-state emitters 132 of solid-state lamp 100 individually and/or in conjunction with one another (e.g., as one or more groupings of emitters 132). In some instances, the touch-sensitive UI may be operatively coupled with one or more controllers 190, which in turn interpret the input from the control interface 202 and provide the desired control signal (s) to one or more of the solid-state emitters 132 of a lamp 100. In some other instances, the touch-sensitive UI may be operatively coupled directly with one or more solid-state emitters 132 to control them directly.

In some embodiments, a computer vision system that is, for example, gesture-sensitive, activity-sensitive, and/or motion-sensitive may be utilized to control the solid-state emitters 132 of a given solid-state lamp 100 individually and/or in conjunction with one another (e.g., as one or more groupings of emitters 132). In some such cases, this may provide for a lamp 100 which can automatically adapt its light emissions based on a particular gesture-based command, sensed activity, or other stimulus. In some instances, the computer vision system may be operatively coupled with one or more controllers 190, which in turn interpret the input from the control interface 202 and provide the desired control signal(s) to one or more of the solid-state emitters 132 of a lamp 100. In some other instances, the computer vision system may be operatively coupled directly with one or more solid-state emitters 132 to control them directly. Other suitable configurations and capabilities for a given controller 190 and the one or more control interfaces 202 will depend on a given application and will be apparent in light of this disclosure.

In some embodiments, lamp 100 may be configured, for example, such that no two of its solid-state emitters 132 are pointed at the same spot on a given surface of incidence. Thus, there may be a one-to-one mapping of the solid-state light sources 130 of lamp 100 to the beam spots which it produces on a given surface of incidence. This one-to-one mapping may provide for pixelated control over the light distribution of lamp 100, in accordance with some embodiments. That is, lamp 100 may be capable of outputting a polar, grid-like pattern of light beam spots which can be manipulated (e.g., in intensity, etc.), for instance, like the regular, rectangular grid of pixels of a display. Like the pixels of a display, the beam spots produced by lamp 100 can have minimal or otherwise negligible overlap, in accordance with some embodiments. This may allow the light distribution of lamp 100 to be manipulated in a manner similar to the way that the pixels of a display can be manipulated to create different patterns, spot shapes, and distributions of light, in accordance with some embodiments. Furthermore, lamp 100 may exhibit minimal or otherwise negligible overlap of the angular distributions of light of its solid-state emitters 132, and thus the candela distribution can be adjusted (e.g., in intensity, etc.) as desired for a given target application or end-use. As will be appreciated in light of this disclosure, however, lamp 100 also may be configured to provide for

pointing two or more solid-state emitters **132** at the same spot (e.g., such as when color mixing using multiple color solid-state emitters **132** is desired), in accordance with some embodiments.

Numerous embodiments will be apparent in light of this disclosure. One example embodiment provides a solid-state lamp including: a base configured to engage a power socket; a plurality of solid-state emitters arranged over a non-planar interior surface of the lamp, wherein at least one of the solid-state emitters is individually addressable to customize its emissions; and one or more focusing optics optically coupled with the plurality of solid-state emitters. In some cases, the non-planar interior surface is concave and is of hemispherical or hyper-hemispherical geometry. In some other cases, the non-planar interior surface is convex and is of hemispherical or hyper-hemispherical geometry. In some instances, the non-planar interior surface is faceted. In some cases, the lamp further includes a heat sink, wherein the heat sink is configured to provide the non-planar interior surface. In some other cases, the lamp further includes a heat sink and a mounting interface coupled with the heat sink, wherein the mounting interface is configured to provide the non-planar interior surface. In some cases, the at least one of the solid-state emitters is a grouping of solid-state emitters. In some such cases, at least one solid-state emitter of the grouping is individually addressable. In some instances, the lamp further includes a controller communicatively coupled with at least one of the plurality of solid-state emitters and configured to output a control signal to electronically control light emitted thereby. In some such instances, the plurality of solid-state emitters are electronically controlled independently of one another by the controller. In some other such instances, the plurality of solid-state emitters are electronically controlled in one or more groupings by the controller. In some instances, the controller is configured to output a control signal that adjusts at least one of beam direction, beam angle, beam diameter, beam distribution, brightness, and/or color of light emitted by at least one of the plurality of solid-state emitters. In some instances, the controller utilizes at least one of a digital multiplexer (DMX) interface protocol, a Wi-Fi protocol, a Bluetooth protocol, a digital addressable lighting interface (DALI) protocol, a ZigBee protocol, a KNX protocol, an EnOcean protocol, a TransferJet protocol, an ultra-wideband (UWB) protocol, a WiMAX protocol, a high performance radio metropolitan area network (HiperMAN) protocol, an infrared data association (IrDA) protocol, a Li-Fi protocol, an IPv6 over low power wireless personal area network (6LoWPAN) protocol, a MyriaNed protocol, a WirelessHART protocol, a DASH7 protocol, a near field communication (NFC) protocol, a Wavenis protocol, a RuBee protocol, a Z-Wave protocol, an Insteon protocol, a ONE-NET protocol, and/or an X10 protocol. In some cases, the lamp further includes a driver operatively coupled with at least one of the plurality of solid-state emitters and configured to adjust at least one of an ON/OFF state, a brightness level, a color of emissions, a correlated color temperature (CCT), and/or a color saturation thereof, wherein the driver utilizes a dimming protocol. In some such instances, the dimming protocol includes at least one of pulse-width modulation (PWM) dimming, current dimming, triode for alternating current (TRIAC) dimming, constant current reduction (CCR) dimming, pulse-frequency modulation (PFM) dimming, pulse-code modulation (PCM) dimming, and/or line voltage (mains) dimming. In some cases, a lighting system is provided, the lighting system including: the solid-state lamp as variously described in this paragraph; and a control interface config-

ured for communicative coupling with the solid-state lamp, the control interface including at least one of a physical control layer and/or a software control layer. In some cases, the physical control layer includes a switch. In some cases, the software control layer is configured to program a lighting pattern/scene for the lamp. In some cases, the software control layer is configured to detect overlap of beam distribution of the solid-state emitters and to adjust emissions thereof.

Another example embodiment provides a solid-state lamp including: a base configured to engage a power socket; a heat sink having a non-planar interior surface; a plurality of light-emitting diodes (LEDs) arranged over the non-planar interior surface of the heat sink; and a driver electronically coupled with at least one of the plurality of LEDs and configured to electronically control output thereof via a dimming protocol. In some cases, the non-planar interior surface of the heat sink is concave and is of hemispherical or hyper-hemispherical geometry. In some other cases, the non-planar interior surface of the heat sink is convex and is of hemispherical or hyper-hemispherical geometry. In some instances, the lamp further includes at least one of a parabolic aluminized reflector (PAR), a bulged reflector (BR), a multi-faceted reflector (MR), and/or a pre-positioning block disposed between the heat sink and at least one of the LEDs. In some cases, the dimming protocol includes at least one of pulse-width modulation (PWM) dimming, current dimming, triode for alternating current (TRIAC) dimming, constant current reduction (CCR) dimming, pulse-frequency modulation (PFM) dimming, pulse-code modulation (PCM) dimming, and/or line voltage (mains) dimming. In some instances, the lamp further includes a transceiver communicatively coupled with the driver, the transceiver configured to utilize at least one of a digital multiplexer (DMX) interface protocol, a Wi-Fi protocol, a Bluetooth protocol, a digital addressable lighting interface (DALI) protocol, a ZigBee protocol, a KNX protocol, an EnOcean protocol, a TransferJet protocol, an ultra-wideband (UWB) protocol, a WiMAX protocol, a high performance radio metropolitan area network (HiperMAN) protocol, an infrared data association (IrDA) protocol, a Li-Fi protocol, an IPv6 over low power wireless personal area network (6LoWPAN) protocol, a MyriaNed protocol, a WirelessHART protocol, a DASH7 protocol, a near field communication (NFC) protocol, a Wavenis protocol, a RuBee protocol, a Z-Wave protocol, an Insteon protocol, a ONE-NET protocol, and/or an X10 protocol.

Another example embodiment provides a solid-state lamp including: a base configured to engage a power socket; a heat sink; a mounting interface thermally coupled with the heat sink and configured to provide a non-planar surface within the lamp; a plurality of light-emitting diodes (LEDs) arranged over the non-planar surface of the mounting interface; and a driver electronically coupled with at least one of the plurality of LEDs and configured to electronically control output thereof via a dimming protocol. In some cases, the non-planar surface of the mounting interface is concave and is of hemispherical or hyper-hemispherical geometry. In some other cases, the non-planar surface of the mounting interface is convex and is of hemispherical or hyper-hemispherical geometry. In some instances, the mounting interface includes at least one of a parabolic aluminized reflector (PAR), a bulged reflector (BR), a multi-faceted reflector (MR), and/or a pre-positioning block. In some cases, the dimming protocol includes at least one of pulse-width modulation (PWM) dimming, current dimming, triode for alternating current (TRIAC) dimming, constant current

reduction (CCR) dimming, pulse-frequency modulation (PFM) dimming, pulse-code modulation (PCM) dimming, and/or line voltage (mains) dimming. In some instances, the lamp further includes a transceiver communicatively coupled with the driver, the transceiver configured to utilize at least one of a digital multiplexer (DMX) interface protocol, a Wi-Fi protocol, a Bluetooth protocol, a digital addressable lighting interface (DALI) protocol, a ZigBee protocol, a KNX protocol, an EnOcean protocol, a TransferJet protocol, an ultra-wideband (UWB) protocol, a WiMAX protocol, a high performance radio metropolitan area network (HyperMAN) protocol, an infrared data association (IrDA) protocol, a Li-Fi protocol, an IPv6 over low power wireless personal area network (6LoWPAN) protocol, a MyriaNed protocol, a WirelessHART protocol, a DASH7 protocol, a near field communication (NFC) protocol, a Wavenis protocol, a RuBee protocol, a Z-Wave protocol, an Insteon protocol, a ONE-NET protocol, and/or an X10 protocol.

The foregoing description of example embodiments has been presented for the purposes of illustration and description. It is not intended to be exhaustive or to limit the present disclosure to the precise forms disclosed. Many modifications and variations are possible in light of this disclosure. It is intended that the scope of the present disclosure be limited not by this detailed description, but rather by the claims appended hereto. Future-filed applications claiming priority to this application may claim the disclosed subject matter in a different manner and generally may include any set of one or more limitations as variously disclosed or otherwise demonstrated herein.

What is claimed is:

1. A lighting system, comprising:
 - one or more solid-state lamps, wherein at least one solid-state lamp comprises:
 - a base configured to engage a power socket;
 - a plurality of solid-state emitters arranged over a non-planar interior surface of the solid-state lamp, wherein at least one of the solid-state emitters is individually addressable to customize its emissions in a direction that is independent from other solid-state emitters in the plurality of solid-state emitters; and
 - one or more focusing optics optically coupled with the plurality of solid-state emitters, wherein the one or more focusing optics are electronically adjustable to control the direction of the emissions of the at least one solid-state emitter; and
 - a control interface configured for communicative coupling with the one or more solid-state lamps, the control interface comprising a software control layer configured to detect overlap of beam distribution of neighboring solid-state lamps and to adjust emissions of the overlapping neighboring solid-state lamps.
2. The system of claim 1, wherein the non-planar interior surface is concave and is of hemispherical or hyper-hemispherical geometry.
3. The system of claim 1, wherein the non-planar interior surface is convex and is of hemispherical or hyper-hemispherical geometry.
4. The system of claim 1, wherein the non-planar interior surface is faceted.

5. The system of claim 1, wherein the at least one solid-state lamp further comprises a heat sink, wherein the heat sink is configured to provide the non-planar interior surface.

6. The system of claim 1, wherein the at least one solid-state lamp further comprises a heat sink and a mounting interface coupled with the heat sink, wherein the mounting interface is configured to provide the non-planar interior surface.

7. The system of claim 1, wherein the at least one of the solid-state emitters is a grouping of solid-state emitters.

8. The system of claim 7, wherein at least one solid-state emitter of the grouping is individually addressable.

9. The system of claim 1, wherein the at least one solid-state lamp further comprises a controller communicatively coupled with at least one of the plurality of solid-state emitters and configured to output a control signal to electronically control light emitted thereby.

10. The system of claim 9, wherein the plurality of solid-state emitters are electronically controlled independently of one another by the controller.

11. The system of claim 9, wherein the plurality of solid-state emitters are electronically controlled in one or more groupings by the controller.

12. The system of claim 9, wherein the controller is configured to output a control signal that adjusts at least one of beam direction, beam angle, beam diameter, beam distribution, brightness, and/or color of light emitted by at least one of the plurality of solid-state emitters.

13. The system of claim 9, wherein the controller utilizes at least one of a digital multiplexer (DMX) interface protocol, a Wi-Fi protocol, a Bluetooth protocol, a digital addressable lighting interface (DALI) protocol, a ZigBee protocol, a KNX protocol, an EnOcean protocol, a TransferJet protocol, an ultra-wideband (UWB) protocol, a WiMAX protocol, a high performance radio metropolitan area network (HyperMAN) protocol, an infrared data association (IrDA) protocol, a Li-Fi protocol, an IPv6 over low power wireless personal area network (6LoWPAN) protocol, a MyriaNed protocol, a WirelessHART protocol, a DASH7 protocol, a near field communication (NFC) protocol, a Wavenis protocol, a RuBee protocol, a Z-Wave protocol, an Insteon protocol, a ONE-NET protocol, and/or an X10 protocol.

14. The system of claim 1, wherein the at least one solid-state lamp further comprises a driver operatively coupled with at least one of the plurality of solid-state emitters and configured to adjust at least one of an ON/OFF state, a brightness level, a color of emissions, a correlated color temperature (CCT), and/or a color saturation thereof, wherein the driver utilizes a dimming protocol.

15. The system of claim 14, wherein the dimming protocol comprises at least one of pulse-width modulation (PWM) dimming, current dimming, triode for alternating current (TRIAC) dimming, constant current reduction (CCR) dimming, pulse-frequency modulation (PFM) dimming, pulse-code modulation (PCM) dimming, and/or line voltage (mains) dimming.

16. The system of claim 1, wherein the control interface further comprises a physical control layer.

17. The system of claim 1, wherein the software control layer is further configured to program a lighting pattern/scene for the one or more solid-state lamps.